

# ICL8038 Precision Waveform Generator/Voltage Controlled Oscillator

## FEATURES

- Low frequency drift with temperature - 50ppm/°C
- Simultaneous sine, square, and triangle wave outputs
- Low distortion - 1% (sine wave output)
- High linearity - 0.1% (triangle wave output)
- Wide operating frequency range - 0.001Hz to 0.3MHz
- Variable duty cycle - 2% to 98%
- High level outputs - TTL to 28V
- Easy to use - just a handful of external components required

## GENERAL DESCRIPTION

The ICL8038 Waveform Generator is a monolithic integrated circuit capable of producing high accuracy sine, square, triangular, sawtooth and pulse waveforms with a minimum of external components. The frequency (or repetition rate) can be selected externally from .001Hz to more than 300kHz using either resistors or capacitors, and frequency modulation and sweeping can be accomplished with an external voltage. The ICL8038 is fabricated with advanced monolithic technology, using Schottky-barrier diodes and thin film resistors, and the output is stable over a wide range of temperature and supply variations. These devices may be interfaced with phase locked loop circuitry to reduce temperature drift to less than 50ppm/°C.

5

## BLOCK DIAGRAM

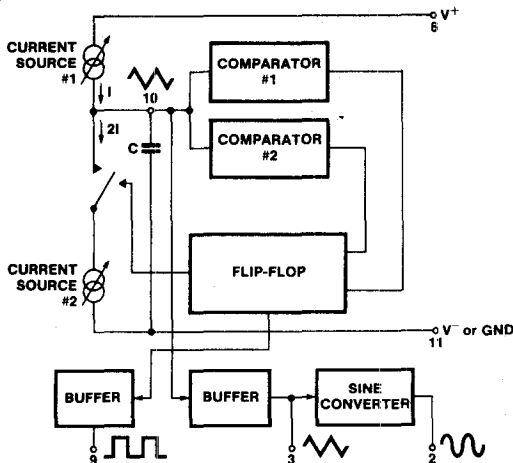

## PIN CONFIGURATION (outline dwg JD)

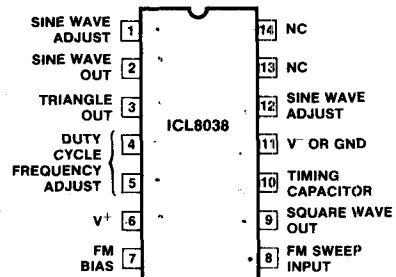

## ORDERING INFORMATION

TYPE	TEMPERATURE RANGE	STABILITY	PACKAGE	ORDER PART NUMBER
8038 CC	0°C to +70°C	50ppm/°C typ	CERDIP	ICL8038 CC JD
8038 BC	0°C to +70°C	100 ppm/°C max	CERDIP	ICL8038 BC JD
8038 AC	0°C to +70°C	50ppm/°C max	CERDIP	ICL8038 AC JD
8038 BM	-55°C to +125°C	100ppm/°C max	CERDIP	ICL8038 BM JD
8038 AM	-55°C to +125°C	50ppm/°C max	CERDIP	ICL8038 AM JD

MAXIMUM RATINGS

Supply Voltage	±18V or 36V Total
Power Dissipation <sup>(1)</sup>	750mW
Input Voltage (any pin)	Not To Exceed Supply Voltages
Input Current (Pins 4 and 5)	25mA
Output Sink Current (Pins 3 and 9)	25mA
Storage Temperature Range	-65°C to +125°C
Operating Temperature Range:	
8038AM, 8038BM	-55°C to +125°C
8038AC, 8038BC, 8038CC	0°C to +70°C
Lead Temperature (Soldering, 10 sec.)	300°C

Stresses above those listed under Absolute Maximum Ratings may cause permanent damage to the device. These are stress ratings only, and functional operation of the device at these or any other conditions above those indicated in the operational sections of the specifications is not implied. Exposure to absolute maximum rating conditions for extended periods may affect device reliability.

**NOTE 1:** Derate ceramic package at 12.5mW/°C for ambient temperatures above 100°C.

ELECTRICAL CHARACTERISTICS

(V<sub>SUPP</sub> = ±10V or +20V, T<sub>A</sub> = 25°C, R<sub>L</sub> = 10kΩ, Test Circuit Unless Otherwise Specified)

SYMBOL	GENERAL CHARACTERISTICS	8038CC			8038BC/BM			8038AC/AM			UNITS
		MIN	TYP	MAX	MIN	TYP	MAX	MIN	TYP	MAX	
V <sub>SUPP</sub>	Supply Voltage Operating Range										
V <sup>+</sup>	Single Supply	+10		+30	+10		30	+10		30	V
V <sup>+</sup> , V <sup>-</sup>	Dual Supplies	±5		±15	±5		±15	±5		±15	V
I <sub>SUPP</sub>	Supply Current (V <sub>SUPP</sub> = ±10V) <sup>(2)</sup>										
	8038AM, 8038BM					12	15		12	15	mA
	8038AC, 8038BC, 8038CC		12	20		12	20		12	20	mA
<b>FREQUENCY CHARACTERISTICS (all waveforms)</b>											
f <sub>max</sub>	Maximum Frequency of Oscillation	100,000			100,000			100,000			Hz
f <sub>sweep</sub>	Sweep Frequency of FM		10			10			10		kHz
	Sweep FM Range <sup>(3)</sup>		40:1			40:1			40:1		
	FM Linearity 10:1 Ratio		0.5			0.2			0.2		%
Δf/ΔT	Frequency Drift With Temperature <sup>(5)</sup>		50			50	100		20	50	ppm/°C
Δf/ΔV	Frequency Drift With Supply Voltage (Over Supply Voltage Range)		0.05			0.05			0.05		%/V <sub>SUPP</sub>
	Recommended Programming Resistors (R <sub>A</sub> and R <sub>B</sub> )	1000		1M	1000		1M	1000		1M	Ω
<b>OUTPUT CHARACTERISTICS</b>											
I <sub>OLK</sub>	Square-Wave Leakage Current (V <sub>g</sub> = 30V)			1			1			1	μA
V <sub>SAT</sub>	Saturation Voltage (I <sub>SINK</sub> = 2mA)		0.2	0.5		0.2	0.4		0.2	0.4	V
t <sub>r</sub>	Rise Time (R <sub>L</sub> = 4.7kΩ)		100			100			100		ns
t <sub>f</sub>	Fall Time (R <sub>L</sub> = 4.7kΩ)		40			40			40		ns
	Duty Cycle Adjust	2		98	2		98	2		98	%
	Triangle/Sawtooth/Ramp Amplitude (R <sub>TRI</sub> = 100kΩ)	0.30	0.33		0.30	0.33		0.30	0.33		xV <sub>SUPP</sub>
	Linearity		0.1			0.05			0.05		%
Z <sub>OUT</sub>	Output Impedance (I <sub>OUT</sub> = 5mA)		200			200			200		Ω
	Sine-Wave Amplitude (R <sub>SINE</sub> = 100kΩ)	0.2	0.22		0.2	0.22		0.2	0.22		xV <sub>SUPP</sub>
	THD (R <sub>S</sub> = 1MΩ) <sup>(4)</sup>		0.8	5		0.7	3		0.7	1.5	%
	THD Adjusted (Use Fig. 8b)		0.5			0.5			0.5		%

**NOTE 2:** R<sub>A</sub> and R<sub>B</sub> currents not included.

**NOTE 3:** V<sub>SUPP</sub> = 20V; R<sub>A</sub> and R<sub>B</sub> = 10kΩ, f ≈ 9kHz; Can be extended to 1000.1. See Figures 13 and 14.

**NOTE 4:** 82kΩ connected between pins 11 and 12, Triangle Duty Cycle set at 50%. (Use R<sub>A</sub> and R<sub>B</sub>.)

**NOTE 5:** Over operating temperature range, Fig. 2, pins 7 and 8 connected, V<sub>SUPP</sub> = ±10V. See Fig. 6c for T.C. vs V<sub>SUPP</sub>.

5

TEST CONDITIONS

PARAMETER	R <sub>A</sub>	R <sub>B</sub>	R <sub>L</sub>	C <sub>1</sub>	SW <sub>1</sub>	MEASURE
Supply Current	10kΩ	10kΩ	10kΩ	3.3nF	Closed	Current into Pin 6
Maximum Frequency of Oscillation	1kΩ	1kΩ	4.7kΩ	100pf	Closed	Frequency at Pin 9
Sweep FM Range <sup>(1)</sup>	10kΩ	10kΩ	10kΩ	3.3nF	Open	Frequency at Pin 9
Frequency Drift with Temperature	10kΩ	10kΩ	10kΩ	3.3nF	Closed	Frequency at Pin 9
Frequency Drift with Supply Voltage <sup>(2)</sup>	10kΩ	10kΩ	10kΩ	3.3nF	Closed	Frequency at Pin 9
Output Amplitude: Sine	10kΩ	10kΩ	10kΩ	3.3nF	Closed	Pk-Pk output at Pin 2
Triangle	10kΩ	10kΩ	10kΩ	3.3nF	Closed	Pk-Pk output at Pin 3
Leakage Current (off) <sup>(3)</sup>	10kΩ	10kΩ	10kΩ	3.3nF	Closed	Current into Pin 9
Saturation Voltage (on) <sup>(3)</sup>	10kΩ	10kΩ	10kΩ	3.3nF	Closed	Output (low) at Pin 9
Rise and Fall Times	10kΩ	10kΩ	4.7kΩ	3.3nF	Closed	Waveform at Pin 9
Duty Cycle Adjust: MAX	50kΩ	~1.6kΩ	10kΩ	3.3nF	Closed	Waveform at Pin 9
MIN	~25kΩ	50kΩ	10kΩ	3.3nF	Closed	Waveform at Pin 9
Triangle Waveform Linearity	10kΩ	10kΩ	10kΩ	3.3nF	Closed	Waveform at Pin 3
Total Harmonic Distortion	10kΩ	10kΩ	10kΩ	3.3nF	Closed	Waveform at Pin 2

**NOTE 1:** The hi and lo frequencies can be obtained by connecting pin 8 to pin 7 (f<sub>hi</sub>) and then connecting pin 8 to pin 6 (f<sub>lo</sub>). Otherwise apply Sweep Voltage at pin 8 ( $2/3 V_{SUPP} + 2V$ )  $\leq V_{SWEEP} \leq V_{SUPP}$  where  $V_{SUPP}$  is the total supply voltage. In Fig. 2, pin 8 should vary between 5.3V and 10V with respect to ground.

**NOTE 2:**  $10V \leq V^* \leq 30V$ , or  $\pm 5V \leq V_{SUPP} \leq \pm 15V$ .

**NOTE 3:** Oscillation can be halted by forcing pin 10 to +5 volts or -5 volts.

DEFINITION OF TERMS:

**Supply Voltage ( $V_{SUPP}$ ).** The total supply voltage from  $V^+$  to  $V^-$ .

**Supply Current.** The supply current required from the power supply to operate the device, excluding load currents and the currents through  $R_A$  and  $R_B$ .

**Frequency Range.** The frequency range at the square wave output through which circuit operation is guaranteed.

**Sweep FM Range.** The ratio of maximum frequency to minimum frequency which can be obtained by applying a sweep voltage to pin 8. For correct operation, the sweep voltage should be within the range

$$(2/3 V_{SUPP} + 2V) < V_{SWEEP} < V_{SUPP}$$

**FM Linearity.** The percentage deviation from the best-fit straight line on the control voltage versus output frequency curve.

**Output Amplitude.** The peak-to-peak signal amplitude appearing at the outputs.

**Saturation Voltage.** The output voltage at the collector of Q<sub>23</sub> when this transistor is turned on. It is measured for a sink current of 2mA.

**Rise and Fall Times.** The time required for the square wave output to change from 10% to 90%, or 90% to 10%, of its final value.

**Triangle Waveform Linearity.** The percentage deviation from the best-fit straight line on the rising and falling triangle waveform.

**Total Harmonic Distortion.** The total harmonic distortion at the sine-wave output.

TEST CIRCUIT

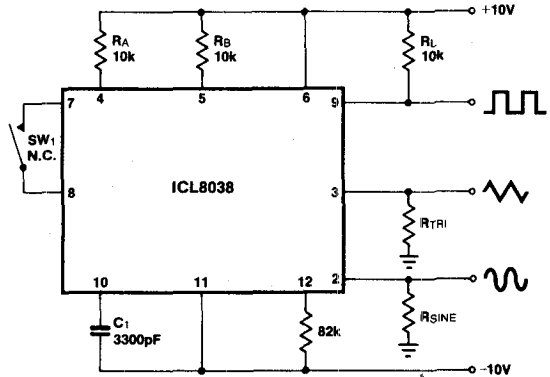

5

TYPICAL PERFORMANCE CHARACTERISTICS

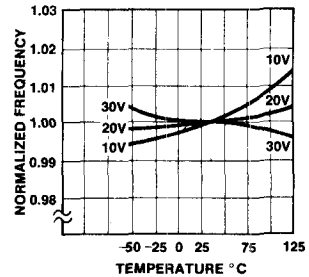
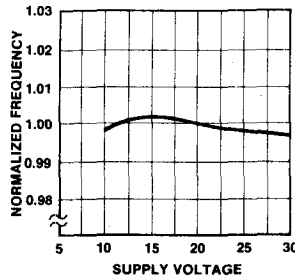
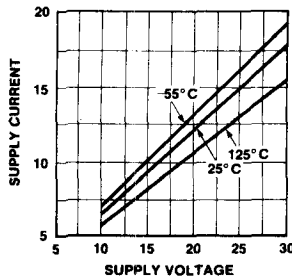

**THEORY OF OPERATION (see block diagram, first page)**

An external capacitor C is charged and discharged by two current sources. Current source #2 is switched on and off by a flip-flop, while current source #1 is on continuously. Assuming that the flip-flop is in a state such that current source #2 is off, and the capacitor is charged with a current I, the voltage across the capacitor rises linearly with time. When this voltage reaches the level of comparator #1 (set at 2/3 of the supply voltage), the flip-flop is triggered, changes states, and releases current source #2. This current source normally carries a current 2I, thus the capacitor is discharged with a net-current I and the voltage across it drops linearly with time. When it has reached the level of comparator #2 (set at 1/3 of the supply voltage), the flip-flop is triggered into its original state and the cycle starts again.

Four waveforms are readily obtainable from this basic generator circuit. With the current sources set at I and 2I respectively, the charge and discharge times are equal. Thus a triangle waveform is created across the capacitor and the flip-flop produces a square-wave. Both waveforms are fed to buffer stages and are available at pins 3 and 9.

The levels of the current sources can, however, be selected over a wide range with two external resistors. Therefore, with the two currents set at values different from I and 2I, an asymmetrical sawtooth appears at terminal 3 and pulses with a duty cycle from less than 1% to greater than 99% are available at terminal 9.

The sine-wave is created by feeding the triangle-wave into a non-linear network (sine-converter). This network provides a decreasing shunt-impedance as the potential of the triangle moves toward the two extremes.

Performance of the Square-Wave Output

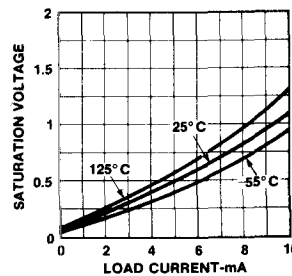
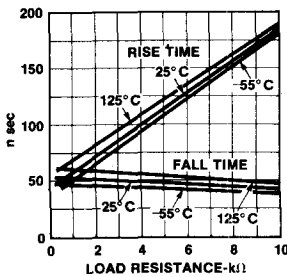

Performance of Triangle-Wave Output

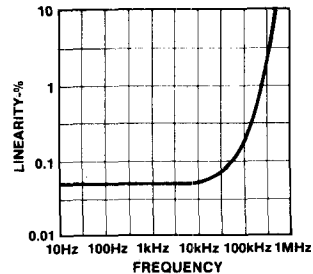
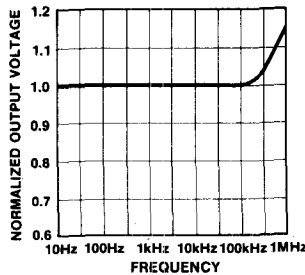
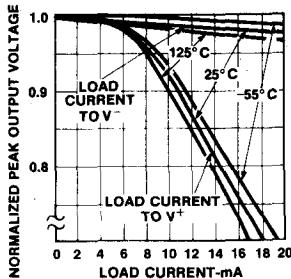

Performance of Sine-Wave Output

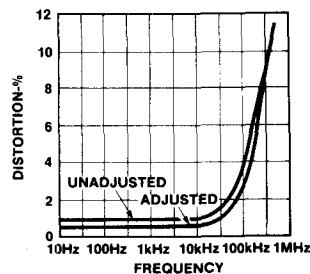
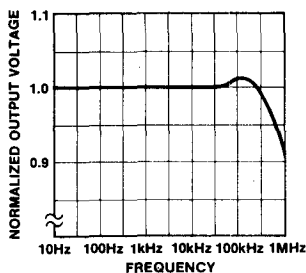

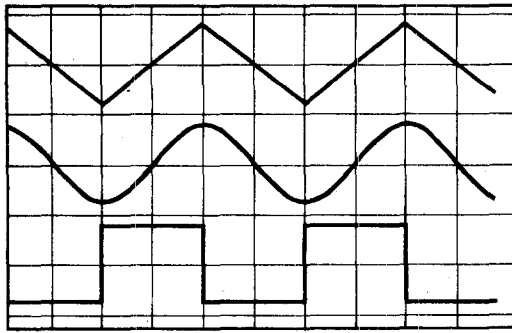

Square-Wave Duty Cycle — 50%

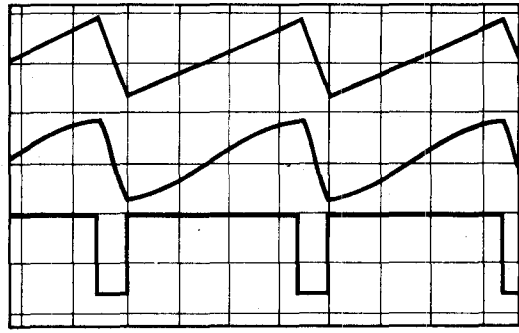

Square-Wave Duty Cycle — 80%

Phase Relationship of Waveforms

**WAVEFORM TIMING**

The *symmetry* of all waveforms can be adjusted with the external timing resistors. Two possible ways to accomplish this are shown in Figure 1. Best results are obtained by keeping the timing resistors  $R_A$  and  $R_B$  separate (a).  $R_A$  controls the rising portion of the triangle and sine-wave and the 1 state of the square-wave.

The magnitude of the triangle-waveform is set at  $1/3 V_{SUPP}$ ; therefore the rising portion of the triangle is,

$$t_1 = \frac{C \times V}{I} = \frac{C \times 1/3 \times V^+ \times R_A}{1/5 \times V^+} = \frac{5}{3} R_A \times C$$

The falling portion of the triangle and sine-wave and the 0 state of the square-wave is:

$$t_2 = \frac{C \times V}{I} = \frac{C \times 1/3 \times V^+}{\frac{2}{5} \times \frac{V_{SUPP}}{R_B} - \frac{1}{5} \times \frac{V_{SUPP}}{R_A}} = \frac{5}{3} \times \frac{R_A R_B C}{2 R_A - R_B}$$

Thus a 50% duty cycle is achieved when  $R_A = R_B$ .

If the duty-cycle is to be varied over a small range about 50% only, the connection shown in Figure 1b is slightly more convenient. If no adjustment of the duty cycle is desired, terminals 4 and 5 can be shorted together, as shown in Figure 1c. This connection, however, causes an inherently larger variation of the duty-cycle, frequency, etc.

With two separate timing resistors, the frequency is given by

$$f = \frac{1}{t_1 + t_2} = \frac{1}{\frac{5}{3} R_A C \left( 1 + \frac{R_B}{2 R_A - R_B} \right)}$$

or, if  $R_A = R_B = R$

$$f = \frac{0.3}{R C} \text{ (for Figure 1a)}$$

If a single timing resistor is used (Figure 1c only), the frequency is

$$f = \frac{0.15}{R C}$$

Neither time nor frequency are dependent on supply voltage, even though none of the voltages are regulated inside the integrated circuit. This is due to the fact that both currents *and* thresholds are direct, linear functions of the supply voltage and thus their effects cancel.

To minimize *sine-wave* distortion the 82kΩ resistor between pins 11 and 12 is best made variable. With this arrangement distortion of less than 1% is achievable. To reduce this even further, two potentiometers can be connected as shown in Figure 2; this configuration allows a typical reduction of sine-wave distortion close to 0.5%.

5

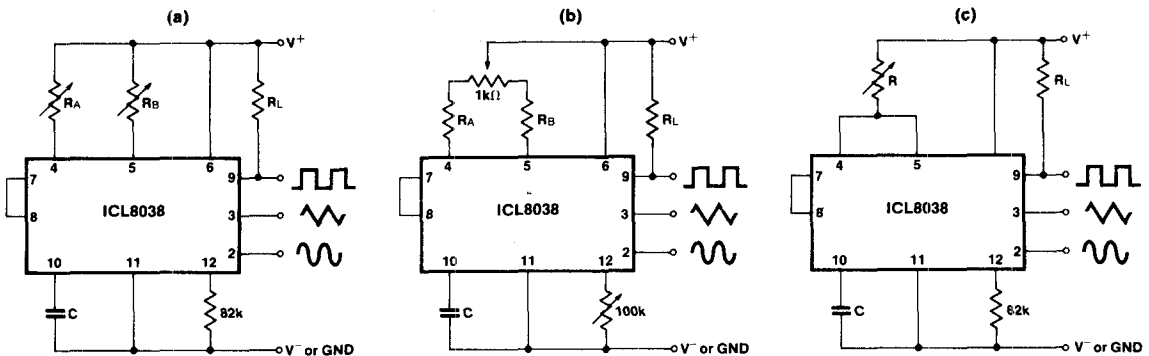

Figure 1: Possible Connections for the External Timing Resistors.

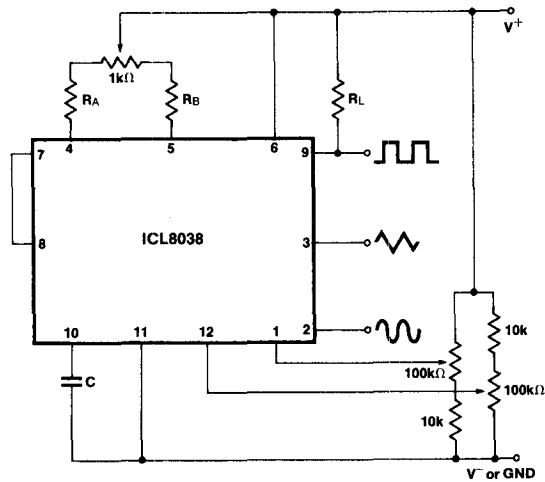

Figure 2: Connection to Achieve Minimum Sine-Wave Distortion.

**SELECTING RA, RB AND C**

For any given output frequency, there is a wide range of RC combinations that will work, however certain constraints are placed upon the magnitude of the charging current for optimum performance. At the low end, currents of less than 1μA are undesirable because circuit leakages will contribute significant errors at high temperatures. At higher currents (I > 5mA), transistor betas and saturation voltages will contribute increasingly larger errors. Optimum performance will, therefore, be obtained with charging currents of 10μA to 1mA. If pins 7 and 8 are shorted together, the magnitude of the charging current due to RA can be calculated from:

$$I = \frac{R_1 \times V_{SUPP}}{(R_1 + R_2)} \times \frac{1}{R_A} = \frac{V_{SUPP}}{5R_A}$$

A similar calculation holds for RB.

The capacitor value should be chosen at the upper end of its possible range.

**WAVEFORM OUT LEVEL CONTROL AND POWER SUPPLIES**

The waveform generator can be operated either from a single power-supply (10 to 30 Volts) or a dual power-supply (±5 to ±15 Volts). With a single power-supply the average levels of the triangle and sine-wave are at exactly one-half of the supply voltage, while the square-wave alternates between V+ and ground. A split power supply has the advantage that all waveforms move symmetrically about ground.

The square-wave output is not committed. A load resistor can be connected to a different power-supply, as long as the applied voltage remains within the breakdown capability of the waveform generator (30V). In this way, the square-wave output can be made TTL compatible (load resistor connected to +5 Volts) while the waveform generator itself is powered from a much higher voltage.

**FREQUENCY MODULATION AND SWEEPING**

The frequency of the waveform generator is a direct function of the DC voltage at terminal 8 (measured from V+). By altering this voltage, frequency modulation is performed.

For small deviations (e.g. ±10%) the modulating signal can be applied directly to pin 8, merely providing DC decoupling with a capacitor as shown in Figure 3a. An external resistor between pins 7 and 8 is not necessary, but it can be used to increase input impedance from about 8kΩ (pins 7 and 8 connected together), to about (R + 8kΩ).

For larger FM deviations or for frequency sweeping, the modulating signal is applied between the positive supply voltage and pin 8 (Figure 3b). In this way the entire bias for the current sources is created by the modulating signal, and a very large (e.g. 1000:1) sweep range is created (f = 0 at V<sub>sweep</sub> = 0). Care must be taken, however, to regulate the supply voltage; in this configuration the charge current is no longer a function of the supply voltage (yet the trigger thresholds still are) and thus the frequency becomes dependent on the supply voltage. The potential on Pin 8 may be swept down from V+ by (1/3 V<sub>SUPP</sub> - 2V).

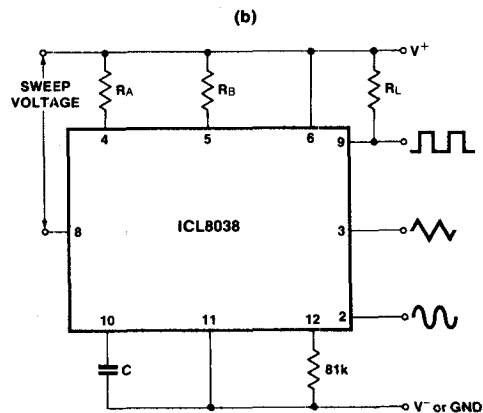
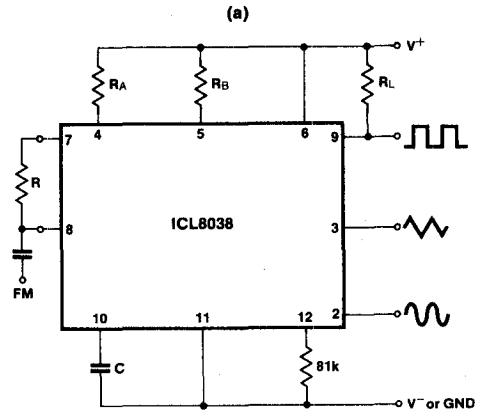
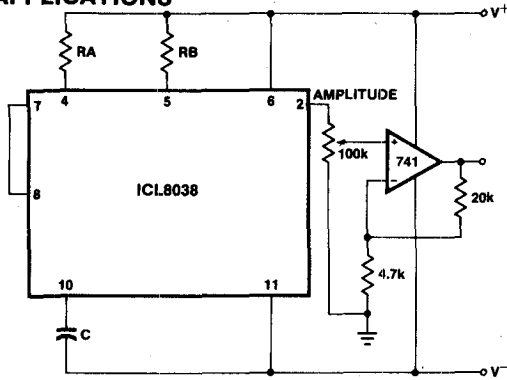

Figure 3: Connections for Frequency Modulation (a) and Sweep (b)

## APPLICATIONS



**Figure 4:** Sine Wave Output Buffer Amplifiers.

The sine wave output has a relatively high output impedance (1kΩ Typ). The circuit of Figure 4 provides buffering, gain and amplitude adjustment. A simple op amp follower could also be used.

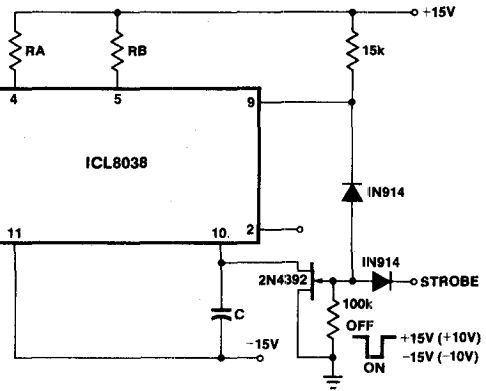

**Figure 5:** Strobe-Tone Burst Generator.

With a dual supply voltage the external capacitor on Pin 10 can be shorted to ground to halt the 8038 oscillation. Figure 5 shows a FET switch, diode ANDED with an input strobe signal to allow the output to always start on the same slope.

5

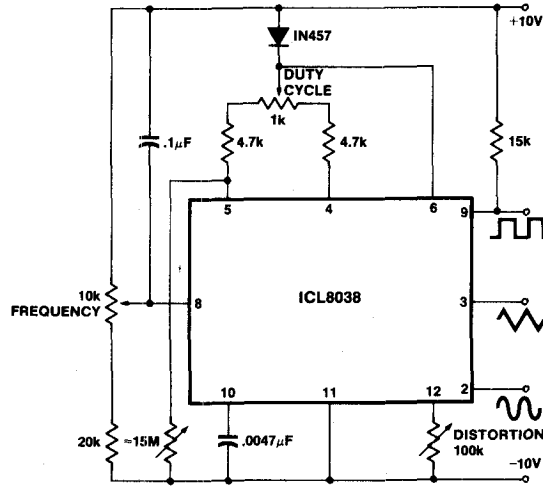

**Figure 6:** Variable Audio Oscillator, 20Hz to 20kHz.

To obtain a 1000:1 Sweep Range on the 8038 the voltage across external resistors RA and RB must decrease to nearly zero. This requires that the highest voltage on control Pin 8 exceed the voltage at the top of RA and RB by a few hundred millivolts.

The Circuit of Figure 6 achieves this by using a diode to lower the effective supply voltage on the 8038. The large resistor on pin 5 helps reduce duty cycle variations with sweep.

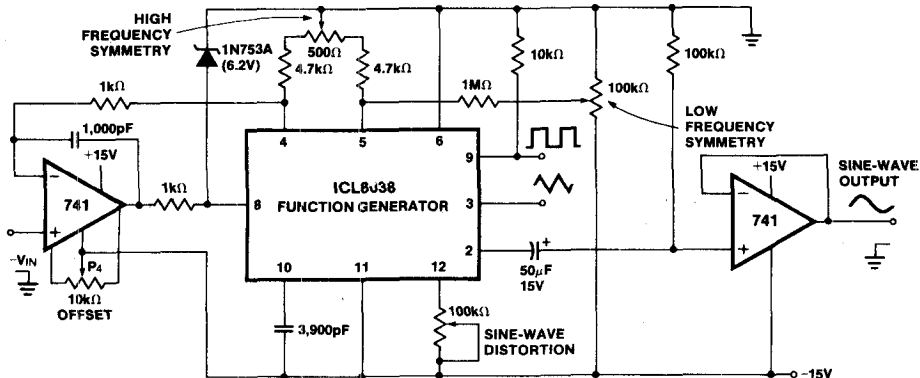

**Figure 7:** Linear Voltage Controlled Oscillator

The linearity of input sweep voltage versus output frequency can be significantly improved by using an op amp as shown in Figure 7.

**USE IN PHASE-LOCKED LOOPS**

Its high frequency stability makes the ICL8038 an ideal building block for a phase-locked loop. In this application the remaining functional blocks, the phase-detector and the amplifier, can be formed by a number of available IC's (e.g. MC 4344, NE 562, HA 2800, HA 2820).

In order to match these building blocks to each other, two steps must be taken. First, two different supply voltages are used and the square wave output is returned to the supply of the phase detector. This assures that the VCO input voltage will not exceed the capabilities of the phase detector. If a smaller VCO signal is required, a simple resistive voltage divider is connected between pin 9 of the waveform generator and the VCO input of the phase-detector.

Second, the DC output level of the amplifier must be made compatible to the DC level required at the FM input of the waveform generator (pin 8,  $0.8 \times V^+$ ). The simplest solution here is to provide a voltage divider to  $V^+$  ( $R_1, R_2$  as shown) if the amplifier has a lower output level, or to ground if its level is higher. The divider can be made part of the low-pass filter.

This application not only provides for a free-running frequency with very low temperature drift, but it also has the unique feature of producing a large reconstituted sinewave signal with a frequency identical to that at the input:

For further information, see Intersil Application Bulletin A013, "Everything You Always Wanted to Know About The 8038."

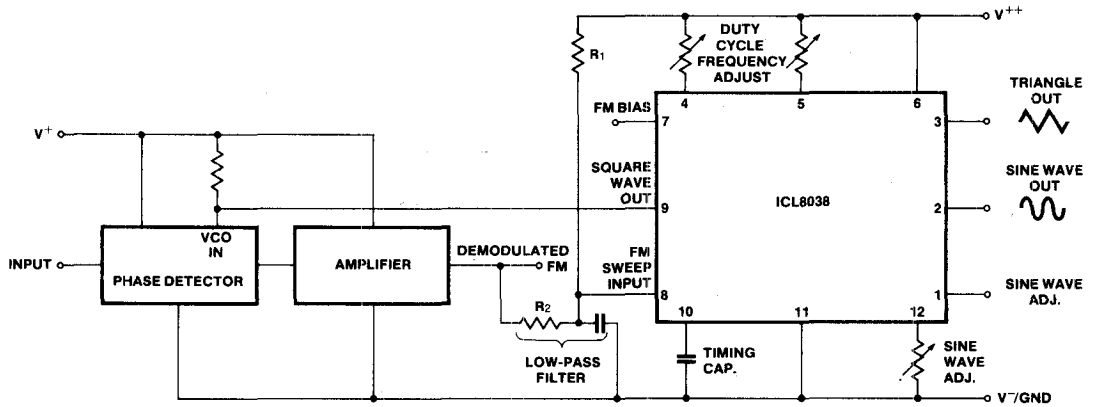

Figure 8: Waveform Generator Used as Stable VCO in a Phase-Locked Loop

5