

Distributed by:

JAMECO[®]
ELECTRONICS

www.Jameco.com ♦ 1-800-831-4242

The content and copyrights of the attached
material are the property of its owner.

Jameco Part Number 848183

DATA SHEET

For a complete data sheet, please also download:

- The IC06 74HC/HCT/HCU/HCMOS Logic Family Specifications
- The IC06 74HC/HCT/HCU/HCMOS Logic Package Information
- The IC06 74HC/HCT/HCU/HCMOS Logic Package Outlines

74HCU04 Hex inverter

Product specification
File under Integrated Circuits, IC06

September 1993

Hex inverter

74HCU04

FEATURES

- Output capability: standard
- I_{CC} category: SSI

GENERAL DESCRIPTION

The 74HCU04 is a high-speed Si-gate CMOS device and is pin compatible with low power Schottky TTL (LSTTL). It is specified in compliance with JEDEC standard no. 7A.

The 74HCU04 is a general purpose hex inverter. Each of the six inverters is a single stage

QUICK REFERENCE DATA

GND = 0 V; $T_{amb} = 25\text{ }^{\circ}\text{C}$; $t_r = t_f = 6\text{ ns}$

SYMBOL	PARAMETER	CONDITIONS	TYP.	UNIT
t_{PHL}/t_{PLH}	propagation delay nA to nY	$C_L = 15\text{ pF}$; $V_{CC} = 5\text{ V}$	5	ns
C_I	input capacitance		3.5	pF
C_{PD}	power dissipation capacitance per inverter	note 1	10	pF

Note

1. C_{PD} is used to determine the dynamic power dissipation (P_D in μW):

$$P_D = C_{PD} \times V_{CC}^2 \times f_i + \sum (C_L \times V_{CC}^2 \times f_o) \text{ where:}$$

f_i = input frequency in MHz

f_o = output frequency in MHz

C_L = output load capacitance in pF

V_{CC} = supply voltage in V

$\sum (C_L \times V_{CC}^2 \times f_o)$ = sum of outputs

ORDERING INFORMATION

See *"74HC/HCT/HCU/HCMOS Logic Package Information"*.

FUNCTION TABLE

INPUT	OUTPUT
nA	nY
L	H
H	L

Note

1. H = HIGH voltage level
L = LOW voltage level

Hex inverter

74HCU04

PIN DESCRIPTION

PIN NO.	SYMBOL	NAME AND FUNCTION
1, 3, 5, 9, 11, 13	1A to 6A	data inputs
2, 4, 6, 8, 10, 12	1Y to 6Y	data outputs
7	GND	ground (0 V)
14	V _{CC}	positive supply voltage

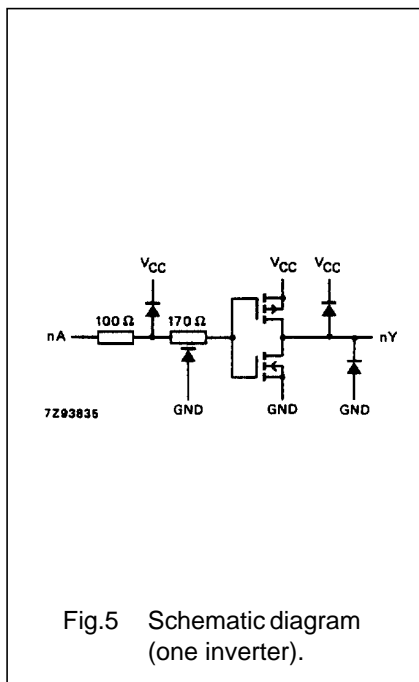
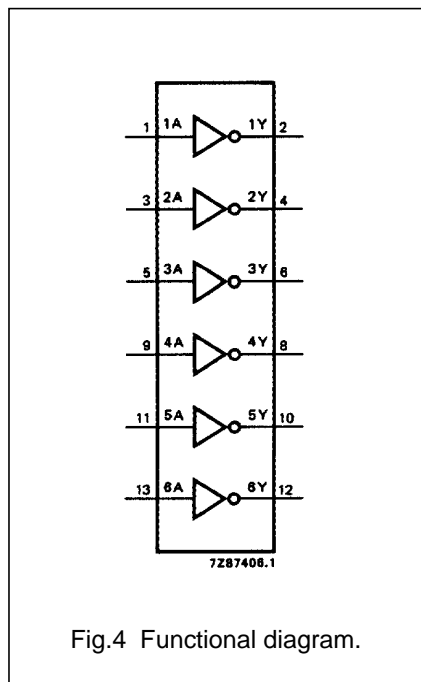
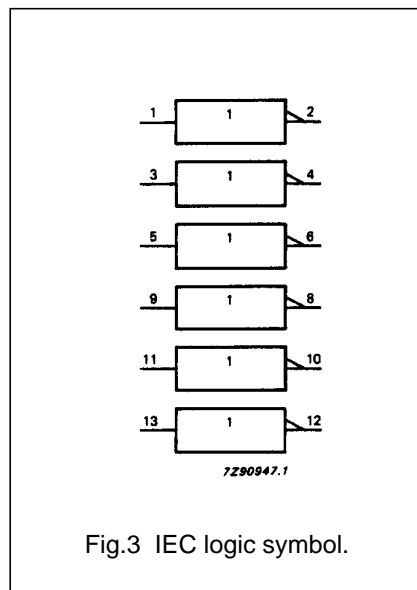
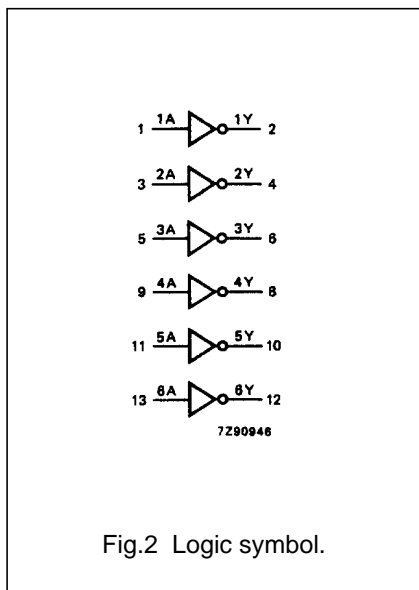
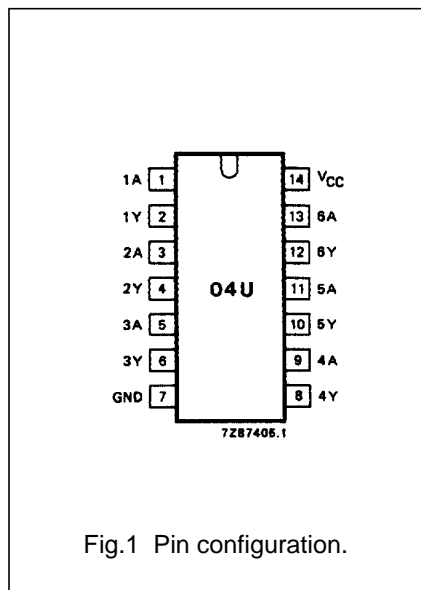

Hex inverter

74HCU04

DC CHARACTERISTICS FOR 74HCU

Voltages are referenced to GND (ground = 0 V)

SYMBOL	PARAMETER	$T_{amb}(^{\circ}C)$							UNIT	TEST CONDITIONS		
		74HCU								V_{CC} (V)	V_I	OTHER
		+25			-40 to +85		-40 to +125					
		min.	typ.	max.	min.	max.	min.	max.				
V_{IH}	HIGH level input voltage	1.7 3.6 4.8	1.4 2.6 3.4		1.7 3.6 4.8		1.7 3.6 4.8		V	2.0 4.5 6.0		
V_{IL}	LOW level input voltage		0.6 1.9 2.6	0.3 0.9 1.2		0.3 0.9 1.2		0.3 0.9 1.2	V	2.0 4.5 6.0		
V_{OH}	HIGH level output voltage	1.8 4.0 5.5	2.0 4.5 6.0		1.8 4.0 5.5		1.8 4.0 5.5		V	2.0 4.5 6.0	V_{IH} or V_{IL}	$-I_O = 20 \mu A$ $-I_O = 20 \mu A$ $-I_O = 20 \mu A$
V_{OH}	HIGH level output voltage	3.98 5.48	4.32 5.81		3.84 5.34		3.7 5.2		V	4.5 6.0	V_{CC} or GND	$-I_O = 4.0 \text{ mA}$ $-I_O = 5.2 \text{ mA}$
V_{OL}	LOW level output voltage		0 0 0	0.2 0.5 0.5		0.2 0.5 0.5		0.2 0.5 0.5	V	2.0 4.5 6.0	V_{IH} or V_{IL}	$I_O = 20 \mu A$ $I_O = 20 \mu A$ $I_O = 20 \mu A$
V_{OL}	LOW level output voltage		0.15 0.16	0.26 0.26		0.33 0.33		0.4 0.4	V	4.5 6.0	V_{CC} or GND	$I_O = 4.0 \text{ mA}$ $I_O = 5.2 \text{ mA}$
$\pm I_I$	input leakage current			0.1		1.0		1.0	μA	6.0	V_{CC} or GND	
I_{CC}	quiescent supply current			2.0		20.0		40.0	μA	6.0	V_{CC} or GND	$I_O = 0$

Hex inverter

74HCU04

AC CHARACTERISTICS FOR 74HCU

GND = 0 V; $t_r = t_f = 6$ ns; $C_L = 50$ pF

SYMBOL	PARAMETER	T_{amb} (°C)						UNIT	TEST CONDITIONS		
		74HCU							V_{CC} (V)	WAVEFORMS	
		+25			-40 to +85		-40 to +125				
		min.	typ.	max.	min.	max.	min.				max.
t_{PHL} / t_{PLH}	propagation delay nA to nY		19 7 6	70 14 12		90 18 15		105 21 18	ns	2.0 4.5 6.0	Fig.6
t_{THL} / t_{TLH}	output transition time		19 7 6	75 15 13		95 19 16		110 22 19	ns	2.0 4.5 6.0	Fig.6

AC WAVEFORMS

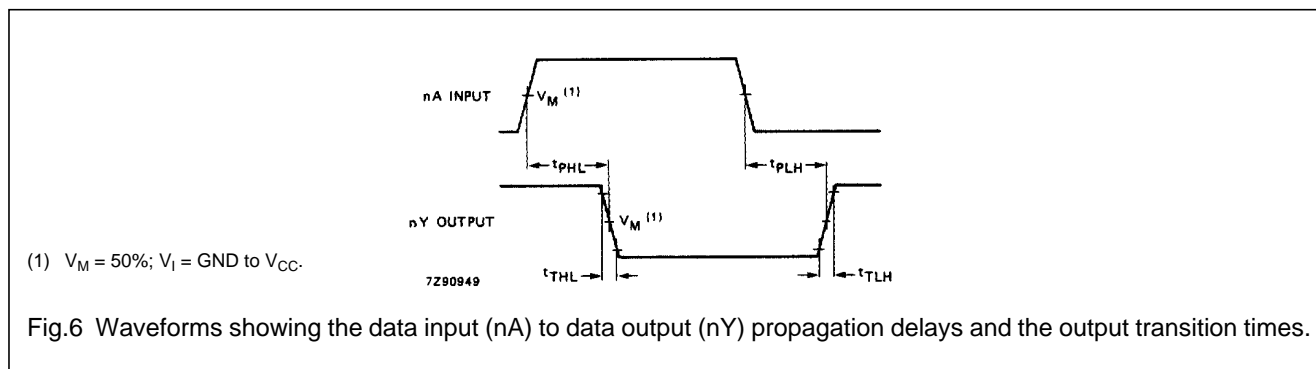

TYPICAL TRANSFER CHARACTERISTICS

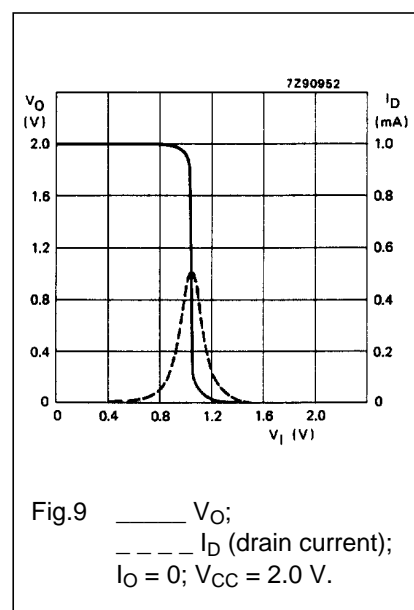
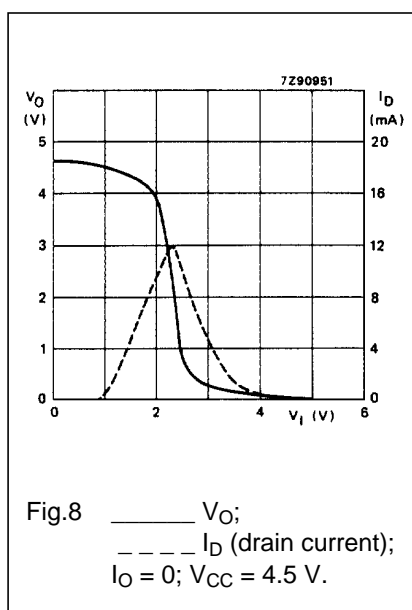
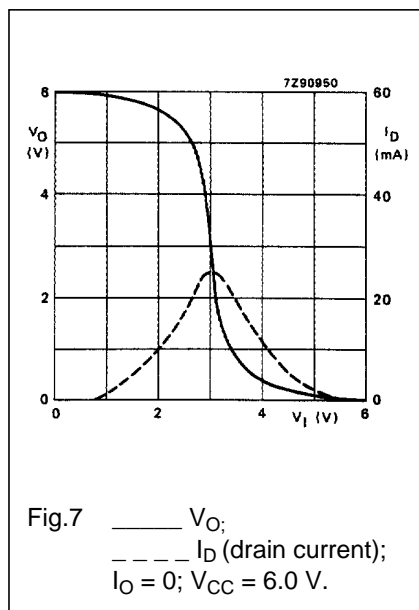

Hex inverter

74HCU04

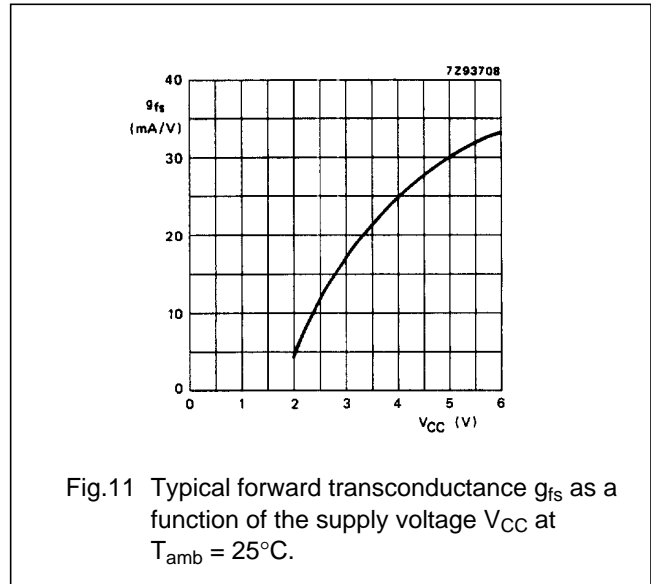
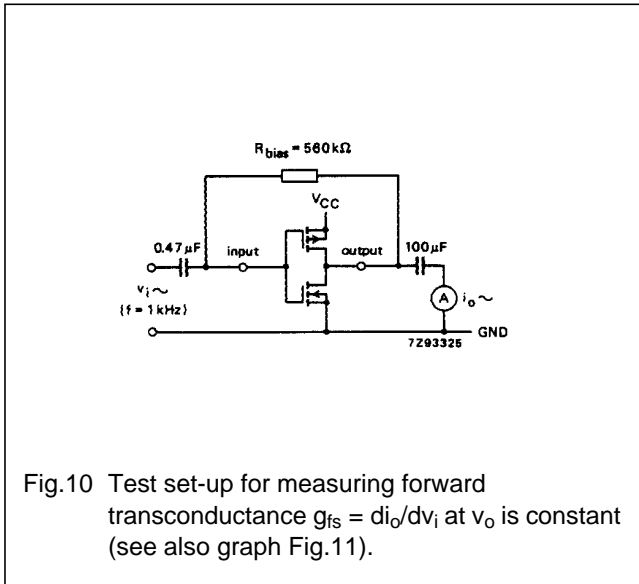

APPLICATION INFORMATION

Some applications for the “HCU04” are:

- Linear amplifier (see Fig.12)
- In crystal oscillator designs (see Fig.13)
- Astable multivibrator (see Fig.14)

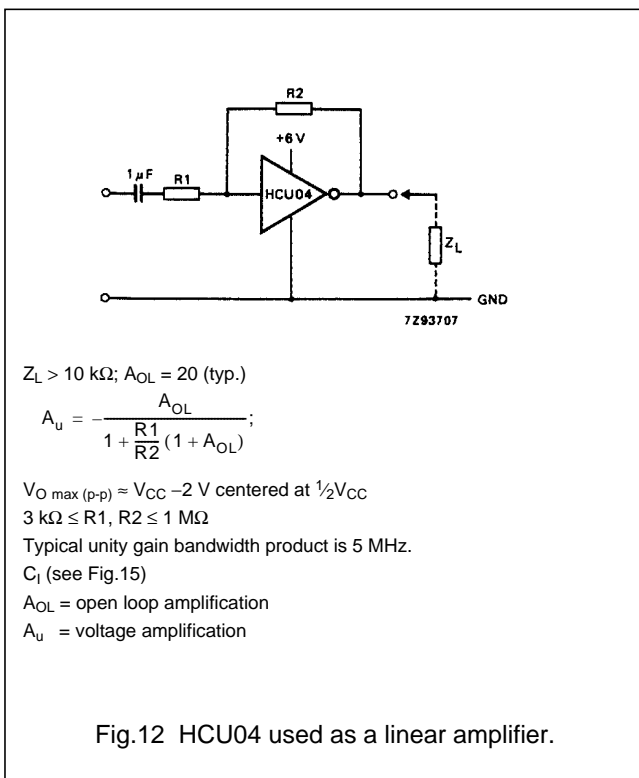

Hex inverter

74HCU04

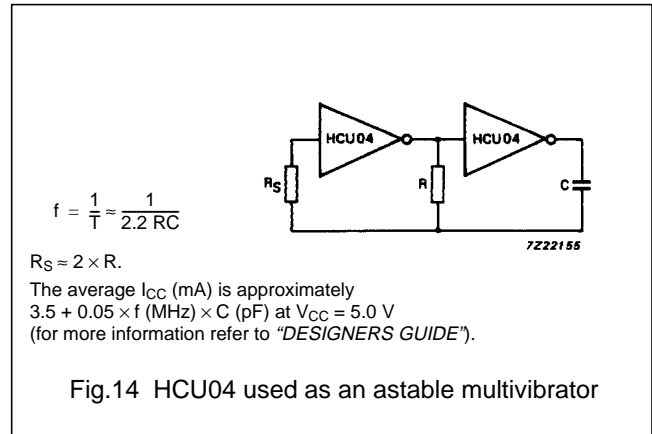
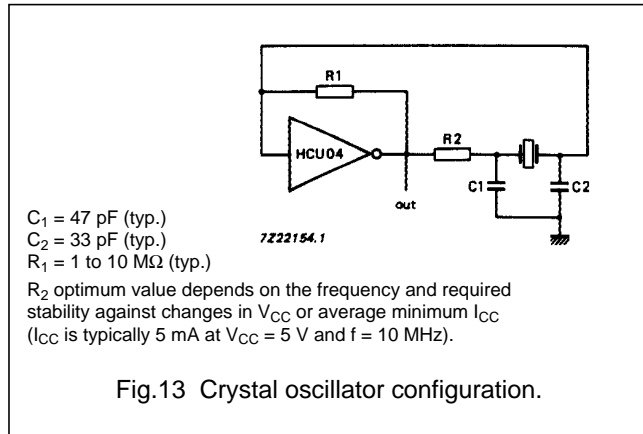

OPTIMUM VALUE FOR R_2

FREQUENCY (MHz)	R_2 (k Ω)	OPTIMUM FOR
3	2 8	minimum required I_{CC} minimum influence due to change in V_{CC}
6	1 4.7	minimum I_{CC} minimum influence by V_{CC}
10	0.5 2	minimum I_{CC} minimum influence by V_{CC}
14	0.5 1	minimum I_{CC} minimum influence by V_{CC}
> 14	replace R_2 by C_3 with a typical value of 35 pF	

EXTERNAL COMPONENTS FOR RESONATOR ($f < 1 \text{ MHz}$)

FREQUENCY (kHz)	R_1 (M Ω)	R_2 (k Ω)	C_1 (pF)	C_2 (pF)
10 to 15.9	22	220	56	20
16 to 24.9	22	220	56	10
25 to 54.9	22	100	56	10
55 to 129.9	22	100	47	5
130 to 199.9	22	47	47	5
200 to 349.9	10	47	47	5
350 to 600	10	47	47	5

Note

- All values given are typical and must be used as an initial set-up.

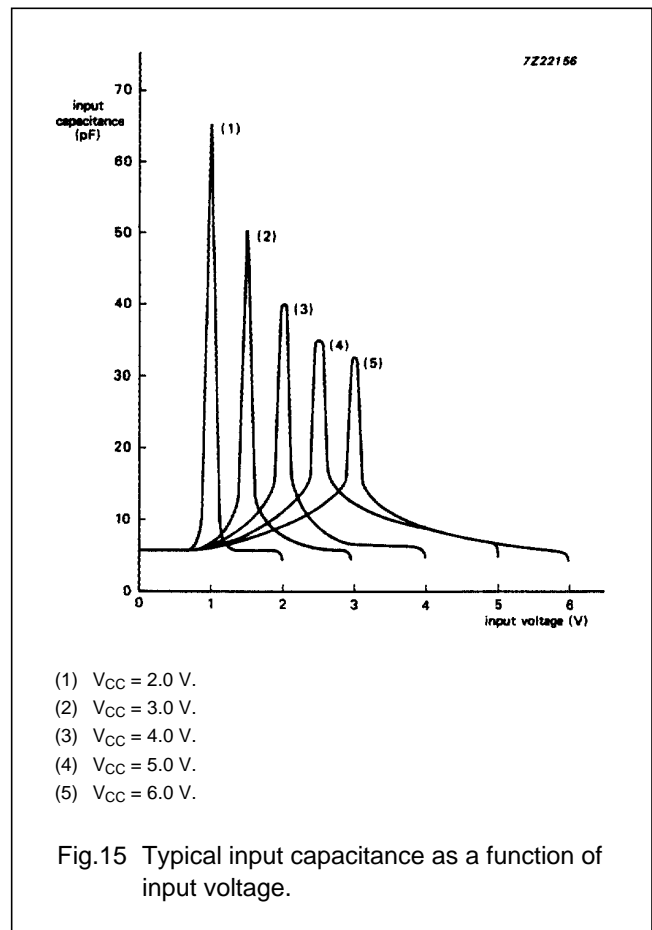

Note to Application information

All values given are typical unless otherwise specified.

PACKAGE OUTLINES

See "74HC/HCT/HCU/HCMOS Logic Package Outlines".