

MC68HC705J2/D
Rev. 2

HCO5

MC68HC705J2

**TECHNICAL
DATA**



MOTOROLA

MC68HC705J2

HCMOS MICROCONTROLLER UNIT

Motorola reserves the right to make changes without further notice to any products herein. Motorola makes no warranty, representation or guarantee regarding the suitability of its products for any particular purpose, nor does Motorola assume any liability arising out of the application or use of any product or circuit, and specifically disclaims any and all liability, including without limitation consequential or incidental damages. "Typical" parameters can and do vary in different applications. All operating parameters, including "Typicals" must be validated for each customer application by customer's technical experts. Motorola does not convey any license under its patent rights nor the rights of others. Motorola products are not designed, intended, or authorized for use as components in systems intended for surgical implant into the body, or other applications intended to support or sustain life, or for any other application in which the failure of the Motorola product could create a situation where personal injury or death may occur. Should Buyer purchase or use Motorola products for any such unintended or unauthorized application, Buyer shall indemnify and hold Motorola and its officers, employees, subsidiaries, affiliates, and distributors harmless against all claims, costs, damages, and expenses, and reasonable attorney fees arising out of, directly or indirectly, any claim of personal injury or death associated with such unintended or unauthorized use, even if such claim alleges that Motorola was negligent regarding the design or manufacture of the part. Motorola and  are registered trademarks of Motorola, Inc. Motorola, Inc. is an Equal Opportunity/Affirmative Action Employer.

NOTE

Change bars indicate changes to manual.

TABLE OF CONTENTS

Paragraph	Title	Page
SECTION 1 INTRODUCTION		
1.1	Features	1-1
1.2	Structure	1-2
SECTION 2 PIN DESCRIPTIONS		
2.1	V_{DD} and V_{SS}	2-2
2.2	OSC1 and OSC2	2-2
2.2.1	Crystal	2-2
2.2.2	Ceramic Resonator	2-2
2.2.3	External Clock	2-3
2.3	\overline{RESET}	2-4
2.4	\overline{IRQ}/V_{PP} (External Interrupt Request/Programming Voltage)	2-4
SECTION 3 PARALLEL I/O		
3.1	I/O Port Function	3-1
3.2	Port A	3-3
3.3	Port B	3-4
SECTION 4 CENTRAL PROCESSOR UNIT		
4.1	CPU Registers	4-1
4.1.1	Accumulator	4-2
4.1.2	Index Register	4-2
4.1.3	Stack Pointer	4-2
4.1.4	Program Counter	4-3
4.1.5	Condition Code Register	4-3
4.1.5.1	Half-Carry Flag	4-3
4.1.5.2	Interrupt Mask	4-3
4.1.5.3	Negative Flag	4-3
4.1.5.4	Zero Flag	4-4
4.1.5.5	Carry/Borrow Flag	4-4
4.2	Arithmetic/Logic Unit (ALU)	4-4
4.3	Low-Power Modes	4-4
4.3.1	STOP Mode	4-4
4.3.2	WAIT Mode	4-7

TABLE OF CONTENTS

Paragraph	Title	Page
SECTION 5		
RESETS AND INTERRUPTS		
5.1	Resets	5-1
5.1.1	Power-On Reset	5-1
5.1.2	External Reset	5-2
5.1.3	Computer Operating Properly (COP) Reset	5-2
5.1.4	Illegal Address Reset	5-2
5.2	Interrupts	5-3
5.2.1	Timer Interrupts	5-4
5.2.1.1	Timer Overflow Interrupts	5-4
5.2.1.2	Real-Time Interrupts	5-4
5.2.2	External Interrupt	5-4
5.2.3	Software Interrupt	5-6
SECTION 6		
MEMORY		
6.1	Memory Map	6-1
6.1.1	Input/Output Section	6-1
6.1.2	RAM	6-1
6.1.3	EPROM	6-4
6.1.3.1	EPROM Programming	6-4
6.1.3.2	EPROM Erasing	6-5
6.1.4	Bootloader ROM	6-5
6.2	Data Retention Mode	6-6
SECTION 7		
TIMER		
7.1	Timer Counter Register (TCR)	7-2
7.2	Timer Control and Status Register (TCSR)	7-2
7.3	COP Timer	7-4
SECTION 8		
BOOTLOADER MODE		
8.1	Bootloader ROM	8-1
8.1.1	External EPROM Downloading	8-1
8.2	Host Downloading	8-3
8.3	Mask Option Register (MOR)	8-4
SECTION 9		
MC68HC05J1 EMULATION MODE		
9.1	Bootloading	9-1
9.2	MC68HC05J1 Emulation	9-1
9.3	Memory Map	9-2

TABLE OF CONTENTS

Paragraph	Title	Page
SECTION 10		
INSTRUCTION SET		
10.1	Addressing Modes	10-1
10.1.1	Inherent.	10-1
10.1.2	Immediate.	10-1
10.1.3	Direct	10-2
10.1.4	Extended.	10-2
10.1.5	Indexed, No Offset	10-2
10.1.6	Indexed, 8-Bit Offset.	10-2
10.1.7	Indexed, 16-Bit Offset.	10-3
10.1.8	Relative.	10-3
10.2	Instruction Types.	10-3
10.2.1	Register/Memory Instructions.	10-4
10.2.2	Read-Modify-Write Instructions	10-5
10.2.3	Jump/Branch Instructions	10-5
10.2.4	Bit Manipulation Instructions.	10-7
10.2.5	Control Instructions.	10-7
10.3	Instruction Set Summary.	10-8
SECTION 11		
ELECTRICAL SPECIFICATIONS		
11.3	Power Considerations.	11-2
11.4	DC Electrical Characteristics ($V_{DD} = 5.0$ Vdc)	11-3
11.5	DC Electrical Characteristics ($V_{DD} = 3.3$ Vdc)	11-4
11.6	Control Timing ($V_{DD} = 5.0$ Vdc)	11-7
11.7	Control Timing ($V_{DD} = 3.3$ Vdc)	11-8
SECTION 12		
MECHANICAL SPECIFICATIONS		
12.1	Plastic Dual In-Line Package (DIP).	12-2
12.2	Small Outline Integrated Circuit (SOIC)	12-3
12.3	Ceramic DIP (Cerdip)	12-4

LIST OF FIGURES

Figure	Title	Page
1-1	MC68HC705J2 Block Diagram	1-2
2-1	Pin Assignments	2-1
2-2	Crystal/Ceramic Resonator Connections	2-3
2-3	External Clock Connections	2-3
3-1	Parallel I/O Port Circuit	3-2
3-2	Port A Data Register	3-3
3-3	Port A Data Direction Register	3-3
3-4	Port B Data Register	3-4
3-5	Port B Data Direction Register	3-4
4-1	Programming Model	4-1
4-2	STOP Instruction Flowchart	4-6
4-3	WAIT Instruction Flowchart	4-8
5-1	COP Control Register	5-2
5-2	Interrupt Stacking Order	5-3
5-3	Interrupt Flowchart	5-5
5-4	External Interrupt Trigger Option	5-6
6-1	Memory Map	6-2
6-2	I/O Registers	6-3
6-3	EPROM Programming Register (PROG)	6-4
7-1	Timer	7-1
7-2	Timer Counter Register (TCR)	7-2
7-3	Timer Control and Status Register (TCSR)	7-2
7-4	COP Register (COPR)	7-4
8-1	Bootloader Circuit	8-2
8-2	Mask Option Register (MOR)	8-4
9-1	MC68HC05J1 Emulation Mode Memory Map	9-2
11-1	Equivalent Test Load	11-4
11-2	Typical High-Side Driver Characteristics	11-5
11-3	Typical Low-Side Driver Characteristics	11-5

LIST OF FIGURES

Figure	Title	Page
11-4	Typical Supply Current vs Clock Frequency	11-6
11-5	Maximum Supply Current vs Clock Frequency	11-6
11-6	External Interrupt Timing	11-7
11-7	STOP Recovery Timing	11-9
11-8	Power-On Reset Timing	11-10
11-9	External Reset Timing	11-10
12-1	MC68HC705J2P (Case 738-03)	12-2
12-2	MC68HC705J2DW (Case 751D-04)	12-3
12-3	MC68HC705J2S (Case 732-03)	12-4

LIST OF TABLES

Table	Title	Page
3-1	I/O Pin Functions	3-2
7-1	Real-Time Interrupt Rate Selection	7-3
8-1	Bootloader Function Selection	8-2
10-1	Register/Memory Instructions	10-4
10-2	Read-Modify-Write Instructions	10-5
10-3	Jump and Branch Instructions	10-6
10-4	Bit Manipulation Instructions	10-7
10-5	Control Instructions	10-7
10-6	Instruction Set Summary	10-8
10-7	Opcode Map	10-14
11-1	Maximum Ratings	11-1
11-2	Thermal Resistance	11-1
11-3	DC Electrical Characteristics ($V_{DD} = 5.0$ Vdc)	11-3
11-4	DC Electrical Characteristics ($V_{DD} = 3.3$ Vdc)	11-4
11-5	Control Timing ($V_{DD} = 5.0$ Vdc)	11-7
11-6	Control Timing ($V_{DD} = 3.3$ Vdc)	11-8

SECTION 1 INTRODUCTION

The MC68HC705J2 is a member of the low-cost, high-performance M68HC05 Family of 8-bit microcontroller units (MCUs). The high-density, complementary metal-oxide semiconductor (HCMOS) M68HC05 Family is based on the customer-specified integrated circuit (CSIC) design strategy. All MCUs in the family use the popular M68HC05 central processor unit (CPU) and are available with a variety of subsystems, memory sizes and types, and package types.

The MC68HC705J2 is an expansion of the MC68HC05J1 design. On-chip memory is enhanced with 2 Kbytes of erasable, programmable ROM (EPROM), 112 Kbytes of RAM, and a bootloader ROM.

1.1 Features

The MCU features include the following:

- Popular M68HC05 CPU
- Memory-Mapped Input/Output (I/O) Registers
- 2064 Bytes of User EPROM Including 16 User Vector Locations
- 112 Bytes of Static RAM (SRAM)
- 14 Bidirectional I/O Pins
- Fully Static Operation With No Minimum Clock Speed
- On-Chip Oscillator With Crystal/Ceramic Resonator Connections
- 15-Bit Multifunction Timer
- Real-Time Interrupt Circuit
- Bootloader ROM
- Power-Saving STOP, WAIT, and Data Retention Modes
- MC68HC05J1 Emulation Mode
- Selectable Edge-Sensitive or Edge- and Level-Sensitive External Interrupt Trigger
- Selectable Computer Operating Properly (COP) Timer
- 8 x 8 Unsigned Multiply Instruction
- One Time Programmable 20-Pin Dual-in-Line Package (DIP)

- One Time Programmable 20-Pin Small Outline Integrated Circuit (SOIC)
- Windowed 20-Pin Cerdip

1.2 Structure

Figure 1-1 shows the organization of the MC68HC705J2 EPROM MCU.

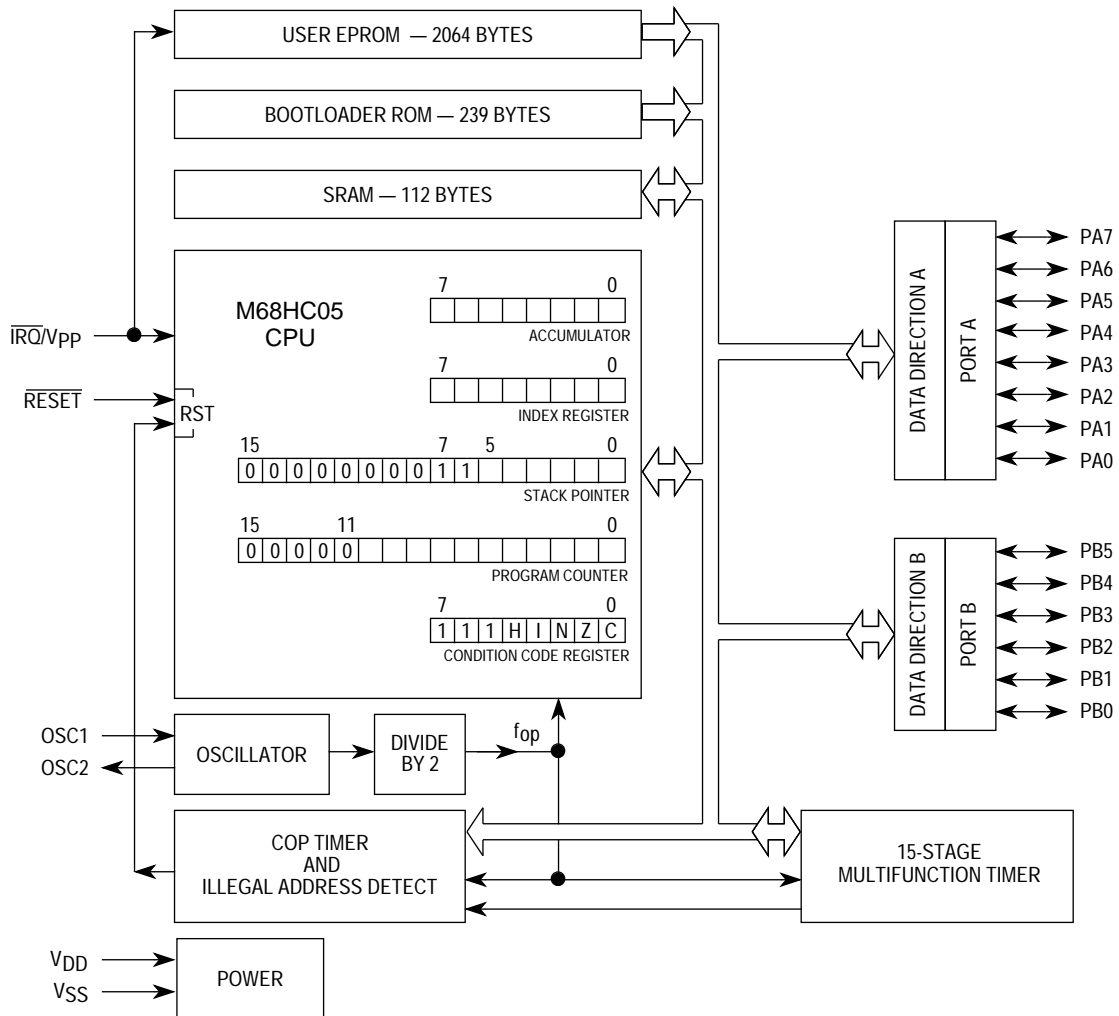

Figure 1-1. MC68HC705J2 Block Diagram

SECTION 2 PIN DESCRIPTIONS

This section describes the function of each pin. [Figure 2-1](#) shows the pin assignments.

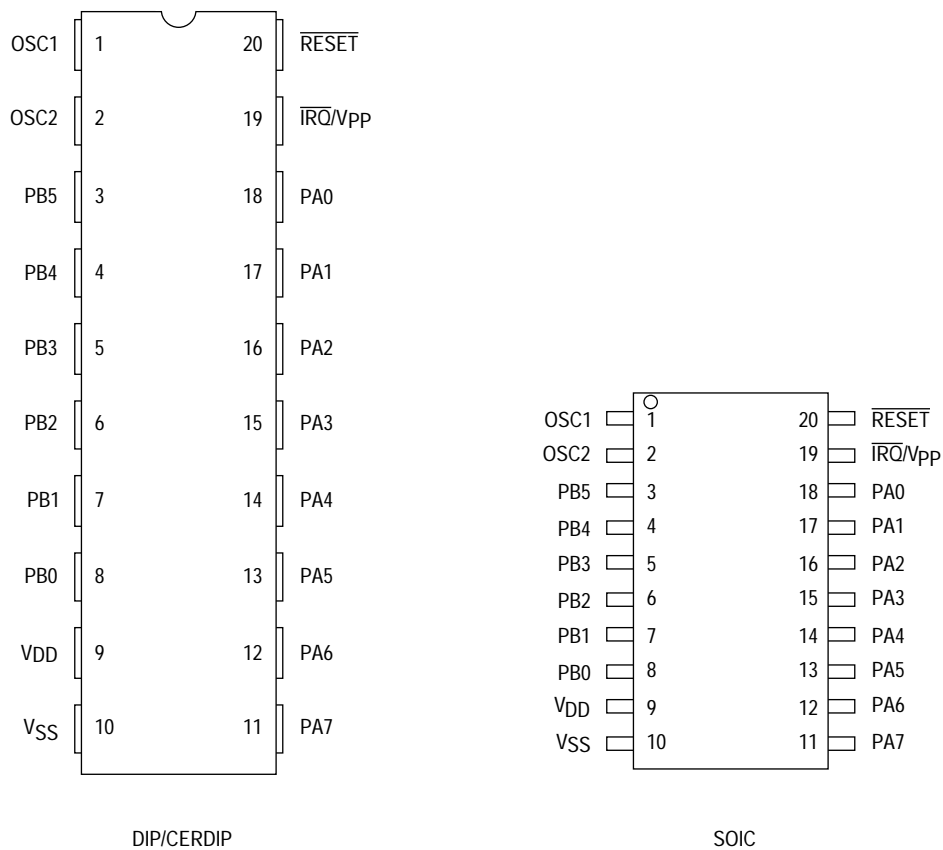

Figure 2-1. Pin Assignments

2.1 V_{DD} and V_{SS}

V_{DD} and V_{SS} are the power supply and ground pins. The MCU operates from a single 5-V power supply.

Very fast signal transitions occur on the MCU pins. The short rise and fall times place very high short-duration current demands on the power supply. To prevent noise problems, take special care to provide good power supply bypassing at the MCU. Use bypass capacitors with good high-frequency characteristics, and position them as close to the MCU as possible. Bypassing requirements vary, depending on how heavily loaded the MCU pins are.

2.2 OSC1 and OSC2

The OSC1 and OSC2 pins are the control connections for the on-chip oscillator. Connect any of the following to the OSC1 and OSC2 pins:

- A crystal (Refer to [Figure 2-2](#).)
- A ceramic resonator (Refer to [Figure 2-2](#))
- An external clock signal (Refer to [Figure 2-3](#))

The MCU divides the frequency, f_{OSC} , of the oscillator or external clock source by two to produce the internal operating frequency, f_{OP} .

2.2.1 Crystal

The circuit in [Figure 2-2](#) shows a typical crystal oscillator circuit for a parallel resonant crystal. Follow the crystal supplier's recommendations, as the crystal parameters determine the external component values required to provide maximum stability and reliable start-up. The load capacitance values used in the oscillator circuit design should include all stray layout capacitances. Mount the crystal and components as close as possible to the pins for start-up stabilization and to minimize output distortion.

2.2.2 Ceramic Resonator

In cost-sensitive applications, use a ceramic resonator in place of the crystal. Use the circuit in [Figure 2-2](#) for a ceramic resonator, and follow the resonator manufacturer's recommendations, as the resonator parameters determine the external component values required for maximum stability and reliable starting. The load capacitance values used in the oscillator circuit design should include all stray layout capacitances.

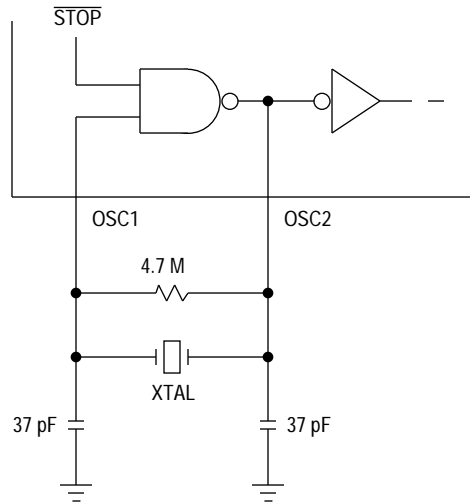

Figure 2-2. Crystal/Ceramic Resonator Connections

2.2.3 External Clock

An external clock from another CMOS-compatible device can drive the OSC1 input, with the OSC2 pin not connected, as [Figure 2-3](#) shows.

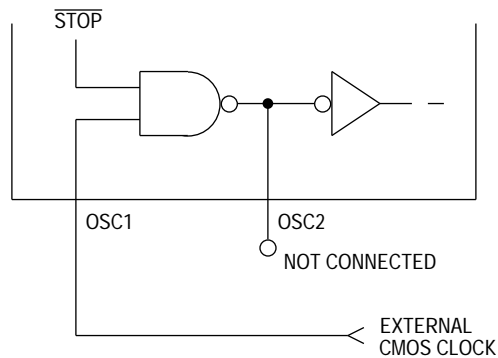

Figure 2-3. External Clock Connections

2.3 $\overline{\text{RESET}}$

A zero on the $\overline{\text{RESET}}$ pin forces the MCU to a known start-up state. See [5.1 Resets](#) for more information.

2.4 $\overline{\text{IRQ}}/V_{\text{PP}}$ (External Interrupt Request/Programming Voltage)

The $\overline{\text{IRQ}}/V_{\text{PP}}$ pin has the following functions:

- Applying asynchronous external interrupt signals (See [5.2 Interrupts](#).)
- Applying the programming voltage for programming the EPROM (See [6.1.3.1 EPROM Programming](#) and [8.1.1 External EPROM Downloading](#).)

SECTION 3 PARALLEL I/O

This section describes the two bidirectional I/O ports.

3.1 I/O Port Function

The 14 I/O pins form two I/O ports. Each I/O pin is programmable as an input or an output. The contents of a port data direction register (DDR) determine the data direction for the port. Writing a 1 to a DDR bit enables the output buffer for the associated port pin; a 0 disables the output buffer. A reset initializes all implemented DDR bits to 0, configuring all I/O pins as inputs.

NOTE

Connect any unused inputs and I/O pins to an appropriate logical level, either V_{DD} or V_{SS} . Although the I/O ports do not require termination for proper operation, termination reduces the possibility of electrostatic damage.

A reset does not initialize the two port data registers. The port data registers for ports A and B are at addresses \$0000 and \$0001. To avoid undefined levels, write the data registers before writing the data direction registers.

With an I/O port pin programmed as an output, reading the pin actually reads the value of the output data latch and not the voltage on the pin itself. When a pin is programmed as an input, reading the port bit reads the voltage level on the I/O pin. The output data latch can always be written, regardless of the state of its DDR bit. Refer to [Figure 3-1](#) for typical port circuitry, and to [Table 3-1](#) for a summary of I/O pin functions.

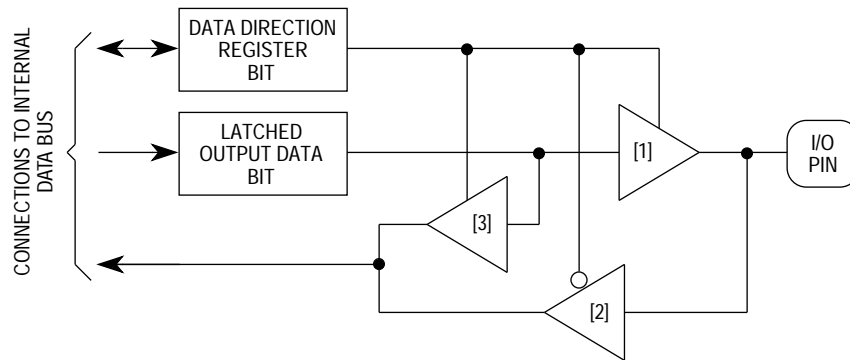

- [1] Output buffer enables latched output to drive I/O pin when DDR bit is 1 (output mode).
- [2] Input buffer enabled when DDR bit is 0 (input mode).
- [3] Input buffer enabled when DDR bit is 1 (output mode).

Figure 3-1. Parallel I/O Port Circuit

Table 3-1. I/O Pin Functions

R/ \bar{W}	DDR Bit	I/O Pin Function
0	0	The I/O pin is an input. Data is written into the output data latch.
0	1	Data is written into the output data latch, which drives the I/O pin.
1	0	The state of the I/O pin is read.
1	1	The I/O pin is an output. The output data latch is read.

NOTE: R/ \bar{W} is an internal MCU signal.

3.2 Port A

Port A is an 8-bit general-purpose bidirectional I/O port. The contents of DDRA determine whether each pin is an input or an output. Figure 3-2 and Figure 3-3 show the port A data register and DDRA.

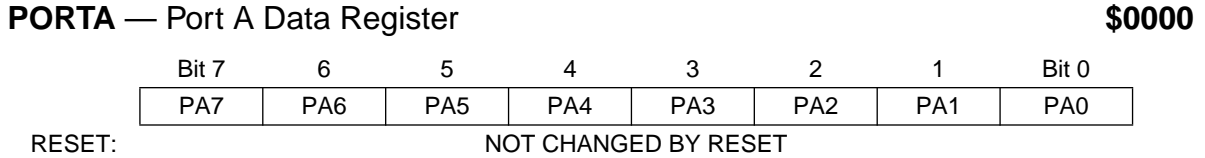

Figure 3-2. Port A Data Register

PA7–PA0 — Port A Data Bits

These read/write bits are software-programmable. Data direction of each bit is under the control of the corresponding DDRA bit.

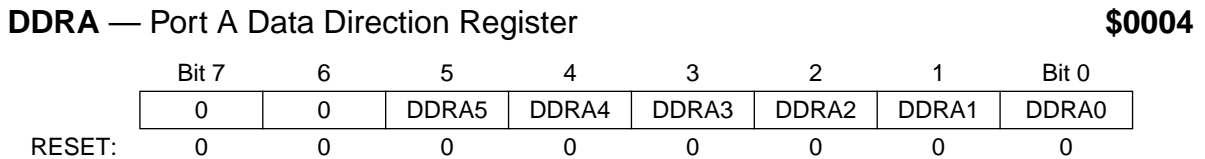

Figure 3-3. Port A Data Direction Register

DDRA7–DDRA0 — Port A Data Direction Bits

These read/write bits control port A data direction.
 1 = Corresponding port A pin configured as output
 0 = Corresponding port A pin configured as input

3.3 Port B

Port B is a 6-bit general-purpose bidirectional I/O port. The contents of DDRB determine whether each pin is an input or an output. [Figure 3-4](#) and [Figure 3-5](#) show the port B data register and DDRB.

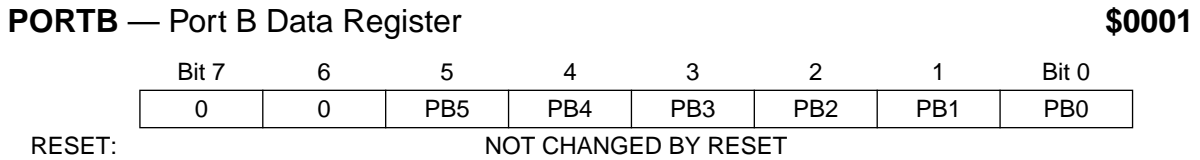

Figure 3-4. Port B Data Register

PB5–PB0 — Port B Data Bits

These read/write bits are software-programmable. Data direction of each bit is under the control of the corresponding DDRA bit.

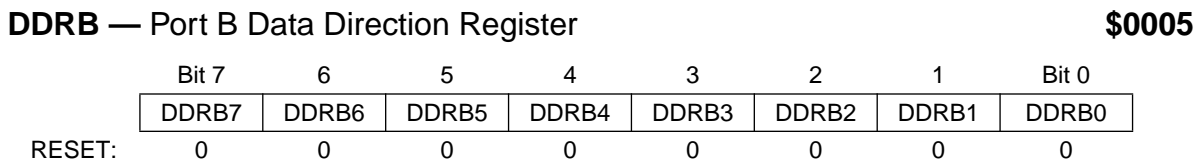

Figure 3-5. Port B Data Direction Register

DDRB7–DDRB0 — Port B Data Direction Bits

These read/write bits control port B data direction.
1 = Corresponding port B pin configured as output
0 = Corresponding port B pin configured as input

SECTION 4 CENTRAL PROCESSOR UNIT

This section describes the registers, arithmetic/logic unit (ALU), and low-power modes of the M68HC05 central processor unit (CPU).

4.1 CPU Registers

Figure 4-1 shows the five CPU registers. These are hard-wired registers within the CPU and are not part of the memory map.

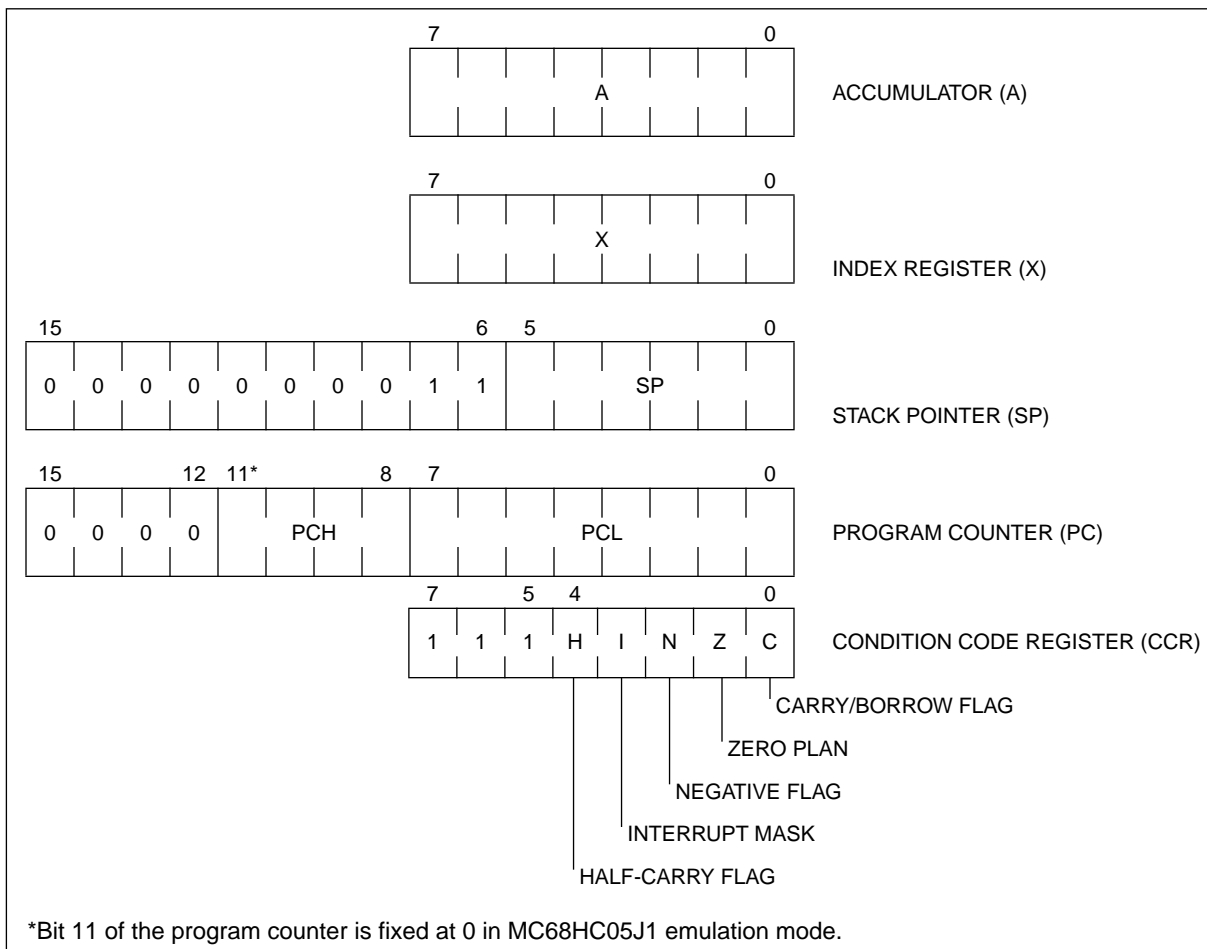

Figure 4-1. Programming Model

4.1.1 Accumulator

The accumulator is a general-purpose 8-bit register. The CPU uses the accumulator to hold operands and results of arithmetic and nonarithmetic operations.

4.1.2 Index Register

The 8-bit index register can perform two functions:

- Indexed addressing
- Temporary storage

In indexed addressing, the CPU uses the byte in the index register to determine the conditional address of the operand.

The index register can also serve as an auxiliary accumulator for temporary storage.

4.1.3 Stack Pointer

The stack pointer is a 16-bit register that contains the address of the next free location on the stack. During a reset or after the reset stack pointer (RSP) instruction, the stack pointer contents are preset to \$00FF. The address in the stack pointer decrements as data is pushed onto the stack and increments as data is pulled from the stack.

The ten most significant bits of the stack pointer are permanently fixed at 0000000011, so the stack pointer produces addresses from \$00C0 to \$00FF. If subroutines and interrupts use more than 64 stack locations, the stack pointer wraps around to address \$00C0 and begins writing over the previously stored data. A subroutine uses two stack locations; an interrupt uses five locations.

4.1.4 Program Counter

The program counter is a 16-bit register that contains the address of the next instruction or operand to be fetched. The four most significant bits of the program counter are permanently fixed at 0000. In MC68HC05J1 emulation mode, the five most significant bits are fixed at 00000.

Normally, the address in the program counter automatically increments to the next sequential memory location every time an instruction or operand is fetched. Jump, branch, and interrupt operations load the program counter with an address other than that of the next sequential location.

4.1.5 Condition Code Register

The condition code register is an 8-bit register whose three most significant bits are permanently fixed at 111. The condition code register contains the interrupt mask and four flags that indicate the results of the instruction just executed. The following paragraphs describe the functions of the condition code register.

4.1.5.1 Half-Carry Flag

The CPU sets the half-carry flag when a carry occurs between bits 3 and 4 of the accumulator during an ADD or ADC operation. The half-carry flag is required for binary-coded decimal (BCD) arithmetic operations.

4.1.5.2 Interrupt Mask

Setting the interrupt mask disables interrupts. If an interrupt request occurs while the interrupt mask is zero, the CPU saves the CPU registers on the stack, sets the interrupt mask, and then fetches the interrupt vector. If an interrupt request occurs while the interrupt mask is set, the interrupt request is latched. Normally, the CPU processes the latched interrupt as soon as the interrupt mask is cleared again.

A return from interrupt (RTI) instruction pulls the CPU registers from the stack, restoring the interrupt mask to its cleared state. After any reset, the interrupt mask is set and can be cleared only by a software instruction.

4.1.5.3 Negative Flag

The CPU sets the negative flag when an arithmetic operation, logical operation, or data manipulation produces a negative result. Bit 7 of the negative result is automatically set, so the negative flag can be used to check an often-tested bit by assigning it to bit 7 of a register or memory location. Loading the accumulator with the contents of that register or location then sets or clears the negative flag according to the state of the tested bit.

4.1.5.4 Zero Flag

The CPU sets the zero flag when an arithmetic operation, logical operation, or data manipulation produces a \$00.

4.1.5.5 Carry/Borrow Flag

The CPU sets the carry/borrow flag when an addition operation produces a carry out of bit 7 of the accumulator. Some logical operations and data manipulation instructions also clear or set the carry/borrow flag.

4.2 Arithmetic/Logic Unit (ALU)

The ALU performs the arithmetic and logical operations defined by the instruction set.

The binary arithmetic circuits decode instructions and set up the ALU for the selected operation. Most binary arithmetic is based on the addition algorithm, carrying out subtraction as negative addition. Multiplication is not performed as a discrete operation but as a chain of addition and shift operations within the ALU. The multiply instruction (MUL) requires 11 internal processor cycles to complete this chain of operations.

4.3 Low-Power Modes

The following paragraphs describe the STOP and WAIT modes. (Refer also to [6.2 Data Retention Mode](#).)

4.3.1 STOP Mode

The STOP instruction puts the MCU in its lowest power-consumption mode. In STOP mode, the following events occur:

- The CPU clears TOF and RTIF, the timer interrupt flags in the timer control and status register, removing any pending timer interrupts.
- The CPU clears TOIE and RTIE, the timer interrupt enable bits in the timer control and status register, disabling further timer interrupts.
- The CPU clears the divide-by-four timer prescaler.
- The CPU clears the interrupt mask in the condition code register, enabling external interrupts.
- The internal oscillator stops, halting all internal processing, including operation of the timer and the COP timer.

The STOP instruction does not affect any other registers or any I/O lines.

The following conditions bring the MCU out of STOP mode:

- An external interrupt. An external interrupt automatically loads the program counter with the contents of locations \$0FFA and \$0FFB, the locations of the vector address of the external interrupt service routine.
- A reset signal on the $\overline{\text{RESET}}$ pin. A reset automatically loads the program counter with the contents of locations \$0FFE and \$0FFF, the locations of the vector address of the reset service routine.

Refer to [Figure 11-7](#) in **SECTION 11 ELECTRICAL SPECIFICATIONS** for STOP recovery timing.

Figure 4-2 shows the sequence of events caused by the STOP instruction.

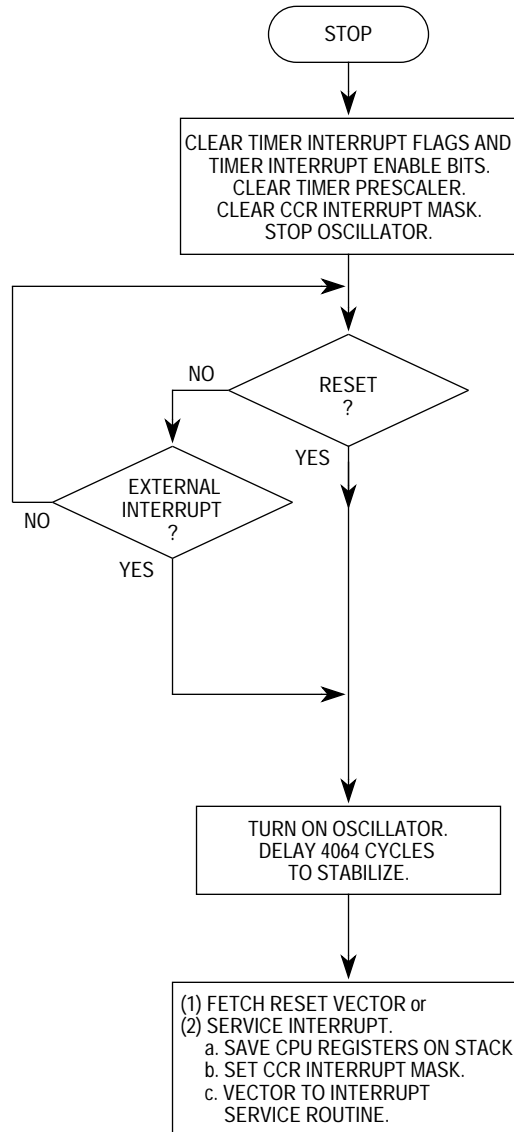

Figure 4-2. STOP Instruction Flowchart

4.3.2 WAIT Mode

The WAIT instruction puts the MCU in an intermediate power-consumption mode. In WAIT mode, the following events occur:

- All CPU clocks stop.
- The CPU clears the interrupt mask in the condition code register, enabling external interrupts and timer interrupts.

The WAIT instruction does not affect any other registers or any I/O lines. The timer and COP timer remain active in WAIT mode.

The following conditions bring the MCU out of WAIT mode:

- A timer interrupt. If a real-time interrupt or a timer overflow interrupt occurs during WAIT mode, the MCU loads the program counter with the contents of locations \$0FF8 and \$0FF9, the locations of the vector address of the timer interrupt service routine.
- An external interrupt. An external interrupt automatically loads the program counter with the contents of locations \$0FFA and \$0FFB, the locations of the vector address of the external interrupt service routine.
- A COP timer reset. A timeout of the COP timer during WAIT mode resets the MCU. The programmer can enable real-time interrupts so the MCU can periodically exit WAIT mode to reset the COP timer.
- A reset signal on the $\overline{\text{RESET}}$ pin during WAIT mode resets the MCU.

A COP timer reset or a reset signal on the $\overline{\text{RESET}}$ pin automatically loads the program counter with the contents of locations \$0FFE and \$0FFF, the locations of the vector address of the reset service routine.

Figure 4-3 shows the sequence of events caused by the WAIT instruction.

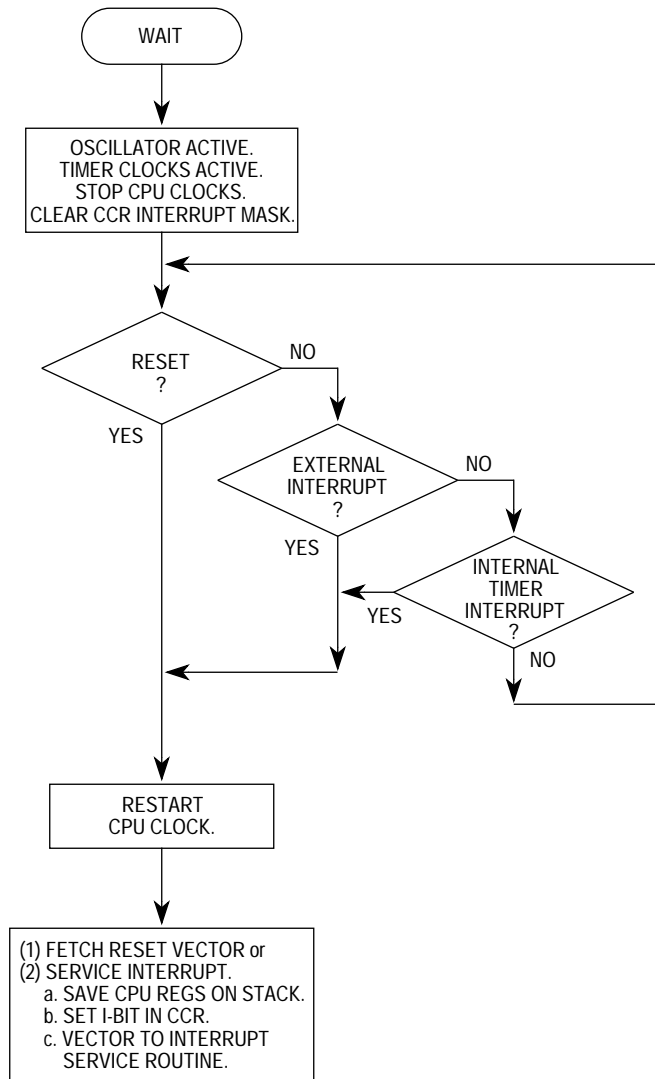

Figure 4-3. WAIT Instruction Flowchart

SECTION 5 RESETS AND INTERRUPTS

This section describes how resets reinitialize the MCU and how interrupts temporarily change the normal processing sequence.

5.1 Resets

A reset immediately stops the operation of the instruction being executed. A reset initializes certain control bits to known conditions and loads the program counter with a user-defined reset vector address. The following conditions produce a reset:

- Initial power-up (power-on reset)
- A logical zero applied to the $\overline{\text{RESET}}$ pin (external reset)
- Timeout of the COP timer (COP reset)
- An opcode fetch from an address not in the memory map (illegal address reset)

A reset does the following things to reinitialize the MCU:

- Clears all implemented data direction register bits so that the corresponding I/O pins are inputs
- Loads the stack pointer with \$FF
- Sets the interrupt mask, inhibiting interrupts
- Clears the TOFE and RTIE bits in the timer control and status register
- Clears the STOP latch, enabling the CPU clocks
- Clears the WAIT latch, waking the CPU from the WAIT mode
- Loads the program counter with the user-defined reset vector

5.1.1 Power-On Reset

A positive transition on the V_{DD} pin generates a power-on reset. The power-on reset is strictly for power-up conditions and cannot be used to detect drops in power supply voltage.

A $4064 t_{cyc}$ (internal clock cycle) delay after the oscillator becomes active allows the clock generator to stabilize. If the $\overline{\text{RESET}}$ pin is at a logical zero at the end of $4064 t_{cyc}$, the MCU remains in the reset condition until the signal on the $\overline{\text{RESET}}$ pin goes to a logical one.

5.1.2 External Reset

A zero applied to the $\overline{\text{RESET}}$ pin for one and one-half t_{cyc} generates an external reset. A Schmitt trigger senses the logic level at the $\overline{\text{RESET}}$ pin.

5.1.3 Computer Operating Properly (COP) Reset

A timeout of the COP timer generates a COP reset. The COP timer is part of a software error detection system and must be cleared periodically to start a new timeout period. (See [7.3 COP Timer](#).) To clear the COP timer and prevent a COP reset, write a zero to bit 0 (COPR) of the COP control register at location $\$0FF0$ before the COP timer times out. The COP control register is a write-only register that returns the contents of an EPROM location when read. See [Figure 5-1](#).

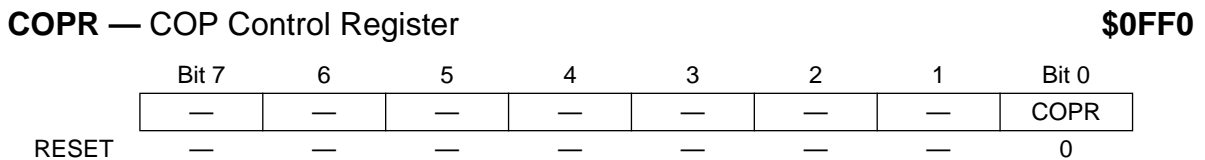

Figure 5-1. COP Control Register

COPR — COP Reset

COPR is a write-only bit. Periodically writing a zero to COPR prevents the COP timer from resetting the MCU.

5.1.4 Illegal Address Reset

An opcode fetch from an address that is not in the EPROM (locations $\$0700$ – $\$0EFF$), or the RAM ($\0090 – $\$00FF$) generates an illegal address reset.

5.2 Interrupts

An interrupt temporarily stops normal processing to process a particular event. Unlike a reset, an interrupt does not stop the operation of the instruction being executed. An interrupt takes effect when the current instruction completes its execution. An interrupt saves the CPU registers on the stack and loads the program counter with a user-defined interrupt vector address. The following conditions produce an interrupt:

- Timer overflow or real-time interrupt request (timer interrupts)
- A logical zero applied to the $\overline{\text{IRQ}}$ pin (external interrupt)
- SWI instruction (software interrupt)

The CPU does the following things to begin servicing an interrupt:

- Stores the contents of the CPU registers on the stack as shown in [Figure 5-2](#)

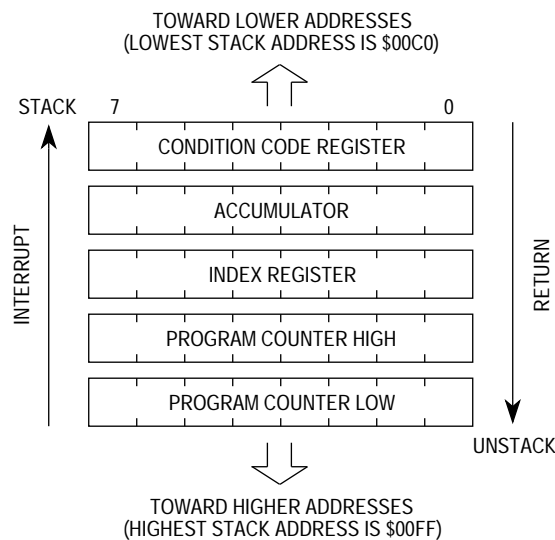

Figure 5-2. Interrupt Stacking Order

- Sets the interrupt mask to prevent further interrupts
- Loads the program counter with the contents of the appropriate interrupt vector locations:
 - \$0FF8 and \$0FF9 (timer interrupt vector)
 - \$0FFA and \$0FFB (external interrupt vector)
 - \$0FFC and \$0FFD (software interrupt vector)

The return from interrupt (RTI) instruction causes the CPU to recover the CPU registers from the stack as shown in [Figure 5-2](#).

5.2.1 Timer Interrupts

The timer generates two kinds of interrupts:

- Timer overflow interrupt
- Real-time interrupt

Setting the interrupt mask in the condition code register disables timer interrupts.

5.2.1.1 Timer Overflow Interrupts

A timer overflow interrupt occurs if the timer overflow flag, TOF, becomes set while the timer overflow interrupt enable bit, TOIE, is also set. TOF and TOIE are in the timer control and status register. See [7.2 Timer Control and Status Register \(TCSR\)](#).

5.2.1.2 Real-Time Interrupts

A real-time interrupt occurs if the real-time interrupt flag, RTIF, becomes set while the real-time interrupt enable bit, RTIE, is also set. RTIF and RTIE are in the timer control and status register. See [7.2 Timer Control and Status Register \(TCSR\)](#).

5.2.2 External Interrupt

When a falling edge occurs on the $\overline{\text{IRQ}}$ pin, an external interrupt request is latched. When the CPU completes its current instruction, it tests the external interrupt latch. If the interrupt latch is set and the interrupt mask in the condition code register is reset, the CPU then begins the interrupt sequence. The CPU clears the interrupt latch while it fetches the interrupt vector, so that another external interrupt request can be latched during the interrupt service routine. As soon as the interrupt mask is cleared (usually during the return from interrupt), the CPU can recognize the new interrupt request.

[Figure 5-3](#) shows the sequence of events caused by an interrupt.

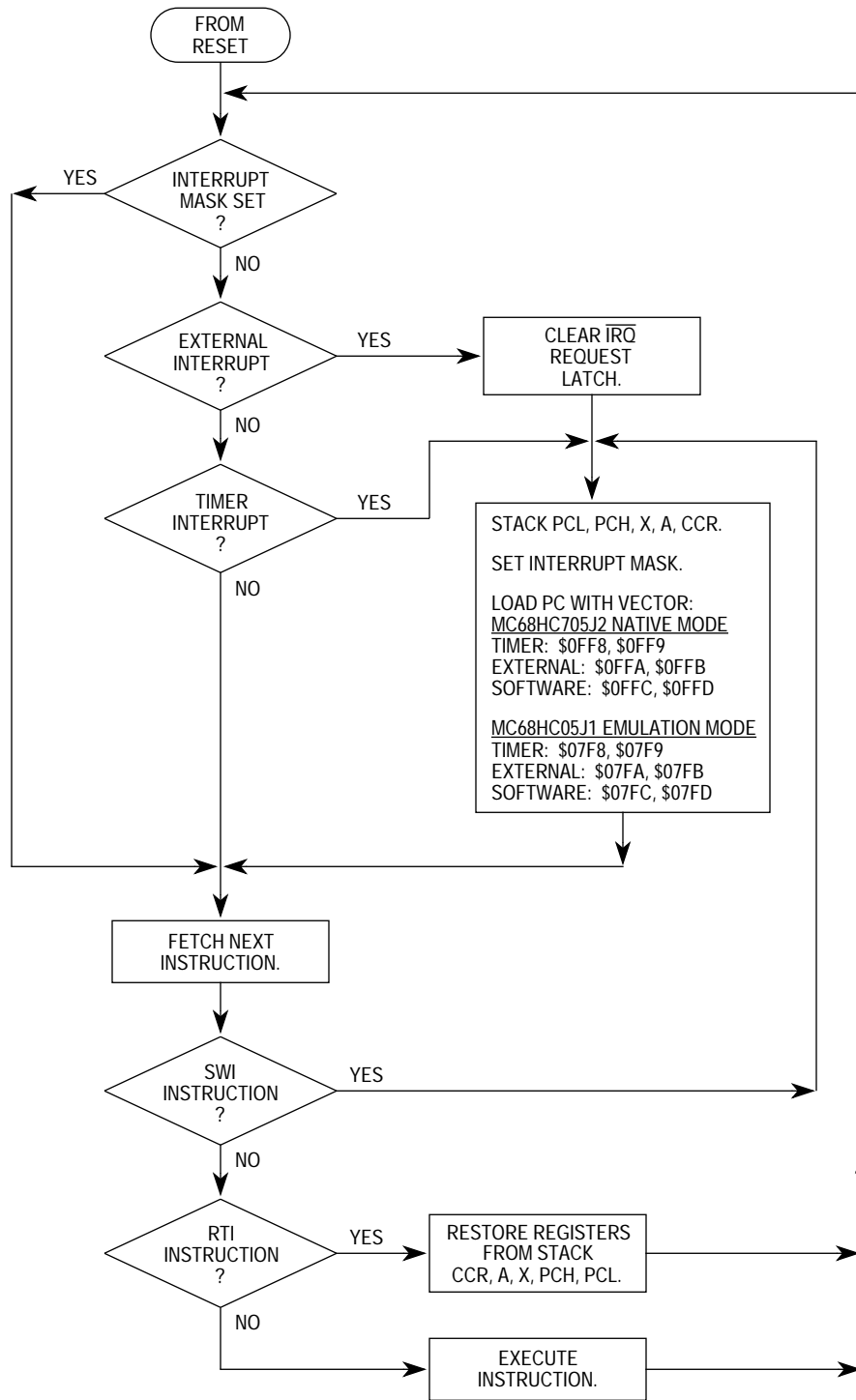

Figure 5-3. Interrupt Flowchart

Either an edge-sensitive or an edge- and level-sensitive external interrupt trigger is programmable in the mask option register. Figure 5-4 shows the internal logic of this programmable option.

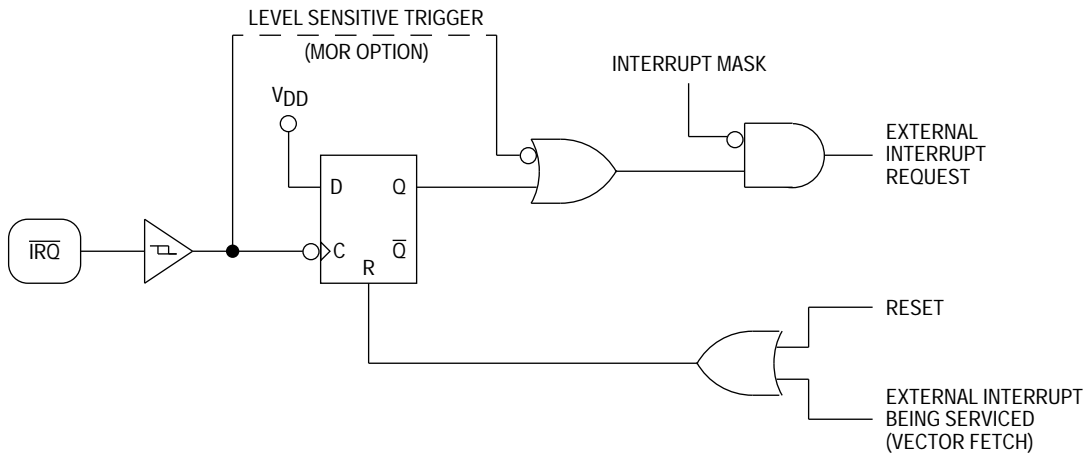

Figure 5-4. External Interrupt Trigger Option

The edge- and level-sensitive trigger option allows multiple external interrupt sources to be wire-ORed to the $\overline{\text{IRQ}}$ pin. With the level-sensitive trigger option, an external interrupt request is latched as long as any source is holding the $\overline{\text{IRQ}}$ pin low.

Setting the interrupt mask in the condition code register disables external interrupts.

5.2.3 Software Interrupt

The software interrupt (SWI) instruction causes a nonmaskable interrupt.

SECTION 6 MEMORY

This section describes the organization of the on-chip memory.

6.1 Memory Map

The CPU can address 4 Kbytes of memory space. The program counter normally advances one address at a time through the memory, reading the program instructions and data. The EPROM portion of memory holds the program instructions, fixed data, user-defined vectors, and service routines. The RAM portion of memory holds variable data. I/O registers are memory-mapped so that the CPU can access their locations in the same way that it accesses all other memory locations.

Figure 6-1 is a memory map of the MCU. Figure 6-2 is a more detailed memory map of the 32-byte I/O register section.

6.1.1 Input/Output Section

The first 32 addresses of the memory space, \$0000–\$001F, are defined as the I/O section. These are the addresses of the I/O control registers, I/O status registers, and I/O data registers.

6.1.2 RAM

The MCU has 112 bytes of fully static read/write memory for storage of variable and temporary data during program execution. RAM addresses \$00C0–\$00FF serve as the stack. The CPU uses the stack to save CPU register contents before processing an interrupt or subroutine call. The stack pointer decrements during pushes and increments during pulls.

NOTE

Be careful if using the stack addresses (\$00C0–\$00FF) for data storage or as a temporary work area. The CPU may overwrite data in the stack during a subroutine or interrupt.

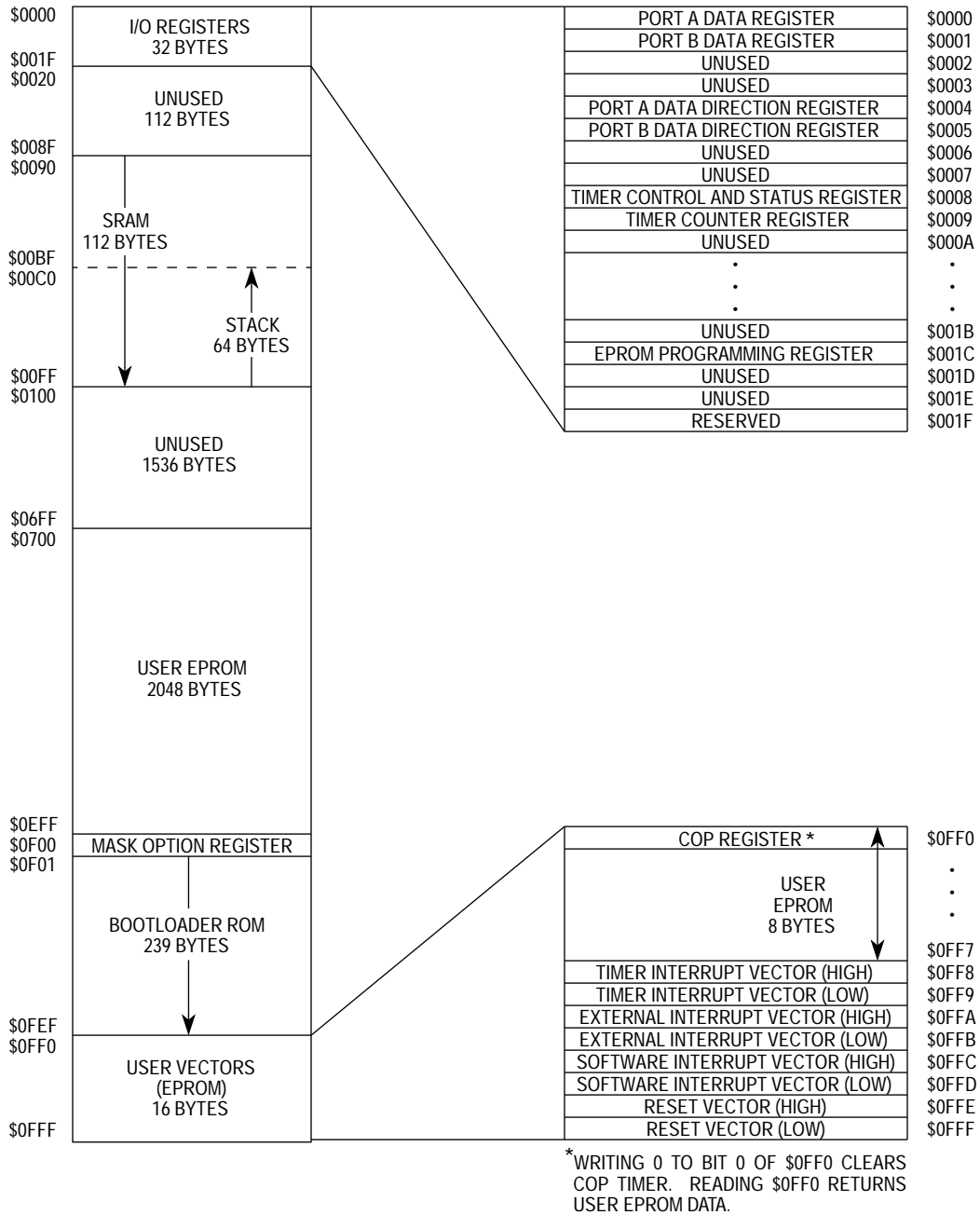

Figure 6-1. Memory Map

	Bit 7	6	5	4	3	2	1	Bit 0	
\$0000	PA7	PA6	PA5	PA4	PA3	PA2	PA1	PA0	PORTA
\$0001	0	0	PB5	PB4	PB3	PB2	PB1	PB0	PORTB
\$0002	—	—	—	—	—	—	—	—	UNUSED
\$0003	—	—	—	—	—	—	—	—	UNUSED
\$0004	DDRA7	DDRA6	DDRA5	DDRA4	DDRA3	DDRA2	DDRA1	DDRA0	DDRA
\$0005	0	0	DDRB5	DDRB4	DDRB3	DDRB2	DDRB1	DDRB0	DDRB
\$0006	—	—	—	—	—	—	—	—	UNUSED
\$0007	—	—	—	—	—	—	—	—	UNUSED
\$0008	TOF	RTIF	TOIE	RTIE	0	0	RT1	RT0	TCSR
\$0009	Bit 7	6	5	4	3	2	1	Bit 0	TCR
\$000A	—	—	—	—	—	—	—	—	UNUSED
\$000B	—	—	—	—	—	—	—	—	UNUSED
\$000C	—	—	—	—	—	—	—	—	UNUSED
•									•
•									•
•									•
\$0019	—	—	—	—	—	—	—	—	UNUSED
\$001A	—	—	—	—	—	—	—	—	UNUSED
\$001B	—	—	—	—	—	—	—	—	UNUSED
\$001C	0	0	0	0	0	LATCH	0	EPGM	PROG
\$001D	—	—	—	—	—	—	—	—	UNUSED
\$001E	—	—	—	—	—	—	—	—	UNUSED
\$001F	—	—	—	—	—	—	—	—	RESERVED
\$0F00	—	—	—	—	—	J1	IRQ	COP	MOR
\$0FF0								COPR	COP

Figure 6-2. I/O Registers

6.1.3 EPROM

Two Kbytes of user EPROM for storage of program instructions and fixed data are located at addresses \$0700–\$0EFF. The eight addresses from \$0FF8–\$0FFF are EPROM locations reserved for interrupt vectors and reset vectors. Eight additional EPROM bytes are located at \$0FF0–\$0FF8. There are two ways to write data to the EPROM:

- The EPROM programming register contains the control bits for programming the EPROM on a byte-by-byte basis.
- The bootloader ROM contains routines to download the contents of an external memory device to the on-chip EPROM.

6.1.3.1 EPROM Programming

The EPROM programming register, shown in [Figure 6-3](#), contains the control bits for programming the EPROM.

PROG — EPROM Programming Register **\$001C**

	Bit 7	6	5	4	3	2	1	Bit 0
	0	0	0	0	0	LATCH	0	EPGM
RESET	0	0	0	0	0	0	0	0

Figure 6-3. EPROM Programming Register (PROG)

LATCH — EPROM Bus Latch

This read/write bit causes address and data buses to be latched for EPROM programming. Clearing the LATCH bit automatically clears the EPGM bit.

- 1 = Address and data buses configured for EPROM programming
- 0 = Address and data buses configured for normal operation

EPGM — EPROM Programming

This read/write bit applies programming power to the EPROM. To write the EPGM bit, the LATCH bit must already be set.

- 1 = EPROM programming power switched on
- 0 = EPROM programming power switched off

Bits 7–3 and 1 — Not used; always read as zeros.

Take the following steps to program a byte of EPROM:

1. Apply 16.5 V to the $\overline{\text{IRQ}}/V_{\text{PP}}$ pin.
2. Set the LATCH bit.
3. Write to any EPROM address.
4. Set the EPGM bit for a time t_{EPGM} to apply the programming voltage.
5. Clear the LATCH bit.

6.1.3.2 EPROM Erasing

The erased state of an EPROM bit is zero. Erase the EPROM by exposing it to 15 Ws/cm^2 of ultraviolet light with a wavelength of 2537 angstroms. Position the ultraviolet light source 1 inch from the EPROM. Do not use a shortwave filter.

NOTE

Windowed packages must have the window covered during programming and operation.

6.1.4 Bootloader ROM

Addresses \$0F01–\$0FEF contain the bootloader ROM, which can copy and verify the contents of an external EPROM to the on-chip EPROM. See [SECTION 8 BOOTLOADER MODE](#).

6.2 Data Retention Mode

In data retention mode, the MCU retains RAM contents and CPU register contents at V_{DD} voltages as low as 2.0 Vdc. The data-retention feature allows the MCU to remain in a low power-consumption state during which it retains data, but the CPU cannot execute instructions.

To put the MCU in data retention mode:

1. Drive the $\overline{\text{RESET}}$ pin to zero.
2. Lower the V_{DD} voltage. The $\overline{\text{RESET}}$ line must remain low continuously during data retention mode.

To take the MCU out of data retention mode:

1. Return V_{DD} to normal operating voltage.
2. Return the $\overline{\text{RESET}}$ pin to logical one.

SECTION 7 TIMER

This section describes the operation of the timer and the COP timer. [Figure 7-1](#) shows the organization of the timer system.

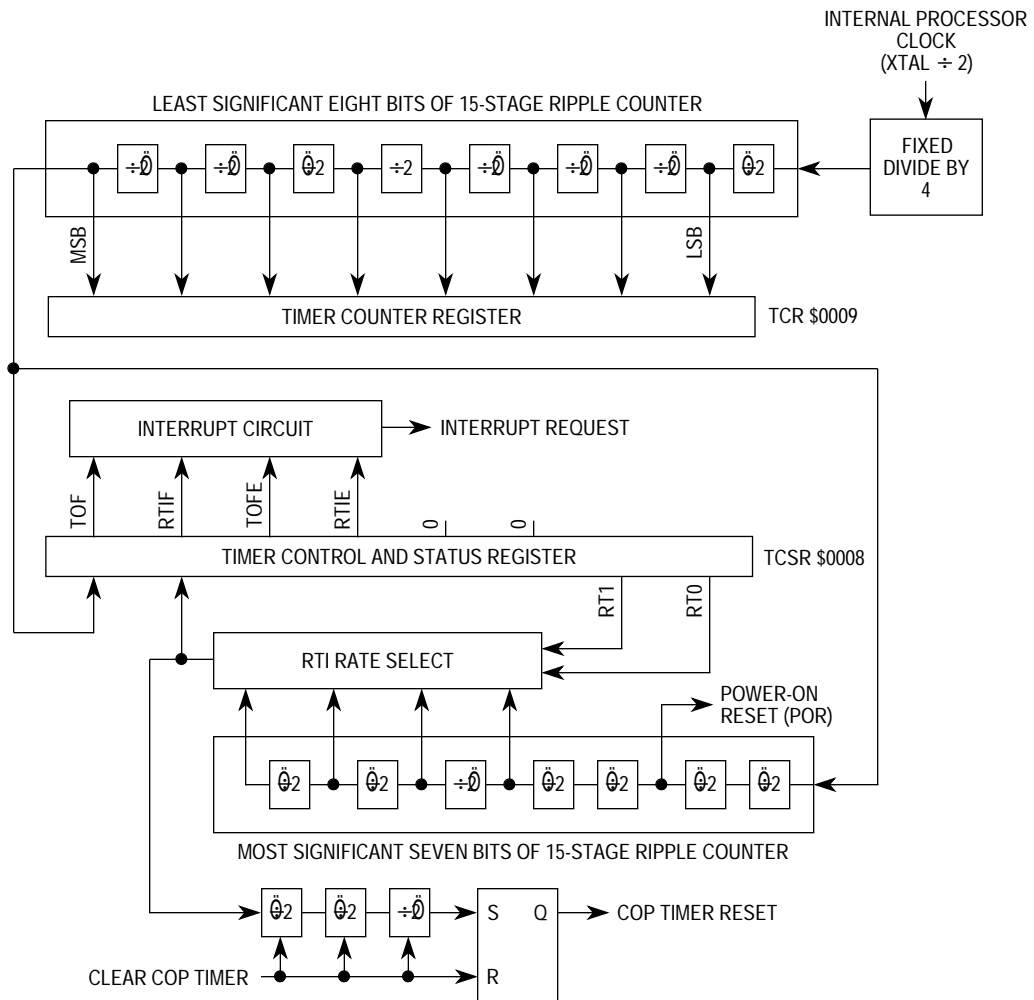

Figure 7-1. Timer

7.1 Timer Counter Register (TCR)

A 15-stage ripple counter is the core of the timer. The value of the first eight stages is readable at any time from the read-only timer counter register shown in [Figure 7-2](#).

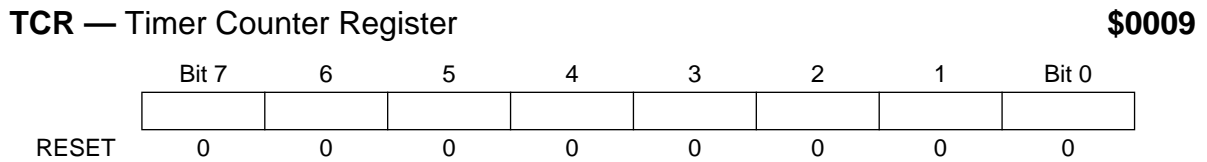

Figure 7-2. Timer Counter Register (TCR)

Power-on clears the entire counter chain and begins clocking the counter. After 4064 cycles of the internal clock, the power-on reset circuit is released, clearing the counter again and allowing the MCU to come out of reset.

A timer overflow function at the eighth counter stage makes timer interrupts possible every 1024 internal clock cycles.

7.2 Timer Control and Status Register (TCSR)

Timer interrupt flags, timer interrupt enable bits, and real-time interrupt rate select bits are in the read/write timer control and status register.

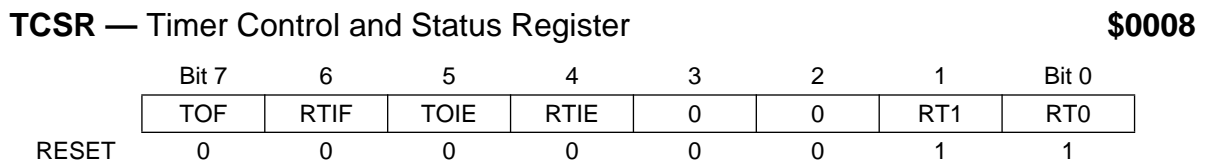

Figure 7-3. Timer Control and Status Register (TCSR)

TOF — Timer Overflow Flag

This clearable, read-only bit becomes set when the first eight stages of the counter roll over from \$FF to \$00. TOF generates a timer overflow interrupt request if TOFE is also set. Clear TOF by writing a zero to it. Writing a one to TOF has no effect.

RTIF — Real-Time Interrupt Flag

This clearable, read-only bit becomes set when the selected RTI output becomes active. RTIF generates a real-time interrupt request if RTIE is also set. Clear RTIF by writing a zero to it. Writing a one to RTIF has no effect.

TOIE — Timer Overflow Interrupt Enable

This read/write bit enables timer overflow interrupts.

- 1 = Timer overflow interrupts enabled
- 0 = Timer overflow interrupts disabled

RTIE — Real-Time Interrupt Enable

This read/write bit enables real-time interrupts

- 1 = Real-time interrupts enabled
- 0 = Real-time interrupts disabled

Bits 3 and 2 — Not used. Always read as zeros.

RT1, RT0 — Real-Time 1 and 0

These read/write bits select one of four real-time interrupt rates. See [Table 7-1](#).

The real-time interrupt rate should be selected by reset initialization software. A reset sets both RT1 and RT0, selecting the lowest real-time interrupt rate. Changing the real-time interrupt rate near the end of the RTI period or during a cycle in which the counter is switching can produce unpredictable results.

Because the selected RTI output drives the COP timer, changing the real-time interrupt rate also changes the counting rate of the COP timer.

Table 7-1. Real-Time Interrupt Rate Selection

RT1:RT0	RTI Rate	RTI Period ($f_{op} = 2 \text{ MHz}$)	COP Timeout Period (-0/+1 RTI Period)	Minimum COP Timeout Period ($f_{op} = 2 \text{ MHz}$)
0 0	$f_{op} \div 2^{14}$	8.2 ms	$7 \times \text{RTI Period}$	57.3 ms
0 1	$f_{op} \div 2^{15}$	16.4 ms	$7 \times \text{RTI Period}$	114.7 ms
1 0	$f_{op} \div 2^{16}$	32.8 ms	$7 \times \text{RTI Period}$	229.4 ms
1 1	$f_{op} \div 2^{17}$	65.5 ms	$7 \times \text{RTI Period}$	458.8 ms

7.3 COP Timer

Three counter stages at the end of the timer make up the computer operating properly (COP) timer. (See [Figure 7-1](#).) The COP timer is a software error detection system that automatically times out and resets the MCU if not cleared periodically by a program sequence. Writing a zero to bit 0 of the COP register clears the COP timer and prevents a COP timer reset. (See [Figure 7-4](#).)

COPR — COP Register

\$0FF0

MC68HC05J1 Emulation Mode: **\$07F0**

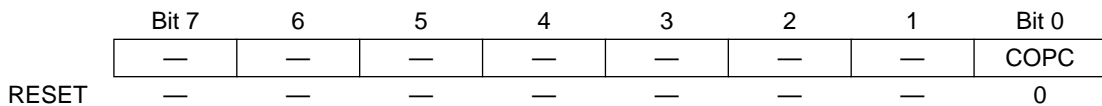

Figure 7-4. COP Register (COPR)

COPC — COP Clear

This write-only bit resets the COP timer. Reading address \$0FF0 returns the EPROM data at that address.

SECTION 8 BOOTLOADER MODE

This section describes how to use the bootloader ROM to download to the on-chip EPROM.

8.1 Bootloader ROM

The bootloader ROM, located at addresses \$0F01–\$0FEF, contains routines for copying to the on-chip EPROM from an external EPROM or from a personal computer.

In MC68HC705J2 native mode, the bootloader copies to the 2 Kbyte space located at EPROM addresses \$0700–\$0EFF, the MOR byte at location \$0F00, and the user vector addresses \$0FF0–\$0FFF. In MC68HC05J1 emulation mode, the bootloader copies to the 1 Kbyte space located at EPROM addresses \$0300–\$06FF, the MOR byte at location \$0700, and the user vector addresses \$07F0–\$07FF. The addresses of the copied code must correspond to the internal addresses to which the code is copied. The bootloader ignores all other addresses.

The COP timer is automatically disabled in bootloader mode.

8.1.1 External EPROM Downloading

Figure 8-1 shows the circuit used to download to the on-chip EPROM from a 2764 EPROM. The bootloader circuit includes an external 12-bit counter to address the EPROM containing the code to be copied.

Operation is fastest when unused external EPROM addresses contain \$00.

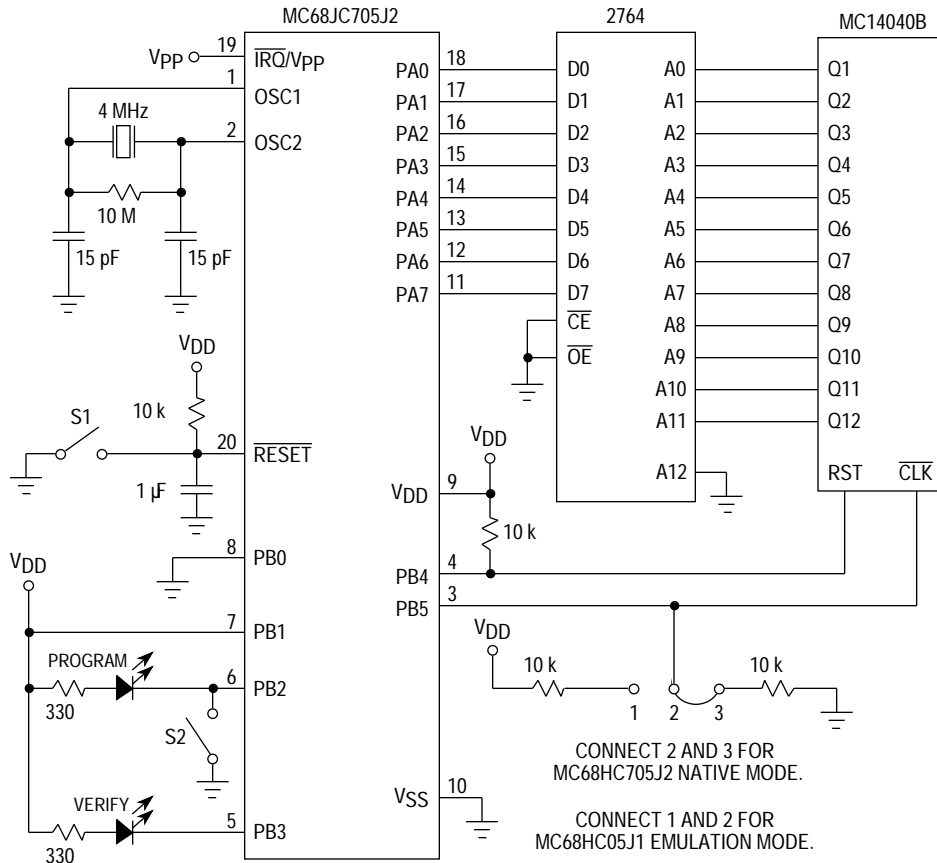

Figure 8-1. Bootloader Circuit

The bootloader function begins when a rising edge occurs on the $\overline{\text{RESET}}$ pin while the $\overline{\text{IRQ/V}_{\text{PP}}}$ pin is at V_{PP} , the PB1 pin is at logical one, and the PB0 pin is grounded.

The PB2 pin selects the bootloader function, as the following table shows.

Table 8-1. Bootloader Function Selection

PB2	Bootloader Function
1	Program and Verify
0	Verify

Complete the following steps to bootstrap the MCU:

1. Turn off all power to the circuit.
2. Install the MCU and the EPROM.
3. Select the MCU mode:
 - a. Install a jumper between points 2 and 3 to program the MCU as an MC68HC705J2.
 - b. Install a jumper between points 1 and 2 to program the MCU as an MC68HC05J1.
4. Select the bootloader function:
 - a. Open switch S2 to select the program and verify function.
 - b. Close switch S2 to select the verify only function.
5. Close switch S1 to reset the MCU.
6. Apply V_{DD} to the circuit.
7. Apply the EPROM programming voltage, V_{PP} , to the circuit.
8. Open switch S1 to take the MCU out of reset. During programming the PROGRAM LED turns on. It turns off when the verification routine begins. If verification is successful, the VERIFY LED turns on. If the bootloader finds an error during verification, it puts the error address on the external address bus and stops running.
9. Close switch S1 to reset the MCU.
10. Remove the V_{PP} voltage.
11. Remove the V_{DD} voltage.

8.2 Host Downloading

The MC68HC05P8EVS board supports downloading user programs directly from a personal computer. Refer to *MC68HC05P8EVS Customer Specified Integrated Circuit (CSIC) Evaluation System*, Motorola document number BR735/D.

8.3 Mask Option Register (MOR)

The mask option register is an EPROM byte that contains three bits to control the following options:

- MC68HC05J1 emulation mode
- External interrupt trigger sensitivity
- COP timer (enable/disable)

The mask option register is programmable only when using the bootloader function to download to the EPROM.

MOR — Mask Option Register **\$0F00**
MC68HC05J1 Emulation Mode: **\$0700**

Bit 7	6	5	4	3	2	1	Bit 0
—	—	—	—	—	J1	IRQ	COP

Figure 8-2. Mask Option Register (MOR)

J1 — MC68HC05J1 Emulation Mode Select

This bit can be read at any time, but can be programmed only by the bootloader.

1 = Emulation mode selected; MCU functions as MC68HC05J1

0 = (Erased state) MC68HC705J2 native mode selected

IRQ — Interrupt Request

This bit can be read at any time, but can be programmed only by the bootloader.

1 = IRQ trigger is both edge-sensitive and level-sensitive

0 = (Erased state) IRQ trigger is edge-sensitive only

COP — COP Timer Enable

This bit can be read at any time, but can be programmed only by the bootloader.

1 = COP timer enabled

0 = (Erased state) COP timer disabled

NOTE

To avoid unintentionally enabling any of the options in the MOR, the user should ensure that location \$0F00 of the 8K external EPROM (2764) is programmed with either the appropriate value for the options to be enabled or \$00. This is necessary because the erased state of an 8K external EPROM is \$FF, whereas the erased state of the MOR is \$00.

SECTION 9

MC68HC05J1 EMULATION MODE

This section describes how to use the MC68HC05J1 emulation mode to achieve compatibility with MC68HC05J1 devices.

9.1 Bootloading

Use the bootloader function to put the MCU in MC68HC05J1 emulation mode. To activate the emulation mode:

1. Connect pin PB5 to V_{DD} in the bootloader circuit.
2. Program the J1 bit (in the mask option register) high.

9.2 MC68HC05J1 Emulation

In MC68HC05J1 emulation mode, the MCU operates as an MC68HC05J1 with the following exceptions:

- The emulation mode does not support the RC oscillator mask option of the MC68HC05J1.
- The emulation mode does not support the STOP disable mask option of the MC68HC05J1.
- The emulation mode has no self-check function.

9.3 Memory Map

Figure 9-1 shows the 2 Kbyte MC68HC05J1 emulation mode memory map.

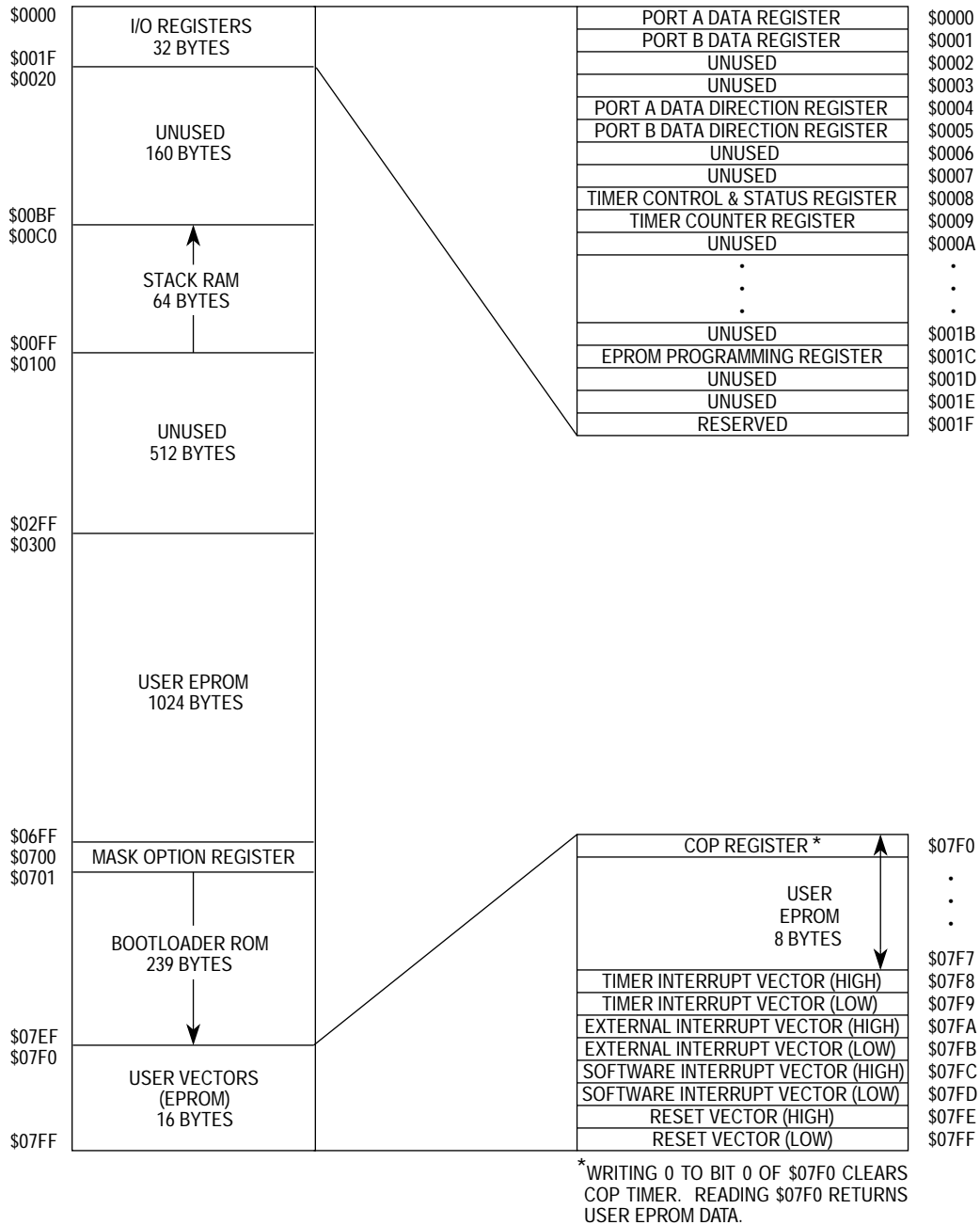

Figure 9-1. MC68HC05J1 Emulation Mode Memory Map

SECTION 10 INSTRUCTION SET

This section describes the M68HC705J1A addressing modes and instruction types.

10.1 Addressing Modes

The CPU uses eight addressing modes for flexibility in accessing data. The addressing modes define the manner in which the CPU finds the data required to execute an instruction. The eight addressing modes are the following:

- Inherent
- Immediate
- Direct
- Extended
- Indexed, no offset
- Indexed, 8-bit offset
- Indexed, 16-bit offset
- Relative

10.1.1 Inherent

Inherent instructions are those that have no operand, such as return from interrupt (RTI) and stop (STOP). Some of the inherent instructions act on data in the CPU registers, such as set carry flag (SEC) and increment accumulator (INCA). Inherent instructions require no memory address and are one byte long.

10.1.2 Immediate

Immediate instructions are those that contain a value to be used in an operation with the value in the accumulator or index register. Immediate instructions require no memory address and are two bytes long. The opcode is the first byte, and the immediate data value is the second byte.

10.1.3 Direct

Direct instructions can access any of the first 256 memory addresses with two bytes. The first byte is the opcode, and the second is the low byte of the operand address. In direct addressing, the CPU automatically uses \$00 as the high byte of the operand address. BRSET and BRCLR are three-byte instructions that use direct addressing to access the operand and relative addressing to specify a branch destination.

10.1.4 Extended

Extended instructions use only three bytes to access any address in memory. The first byte is the opcode; the second and third bytes are the high and low bytes of the operand address.

When using the Motorola assembler, the programmer does not need to specify whether an instruction is direct or extended. The assembler automatically selects the shortest form of the instruction.

10.1.5 Indexed, No Offset

Indexed instructions with no offset are one-byte instructions that can access data with variable addresses within the first 256 memory locations. The index register contains the low byte of the conditional address of the operand. The CPU automatically uses \$00 as the high byte, so these instructions can address locations \$0000–\$00FF.

Indexed, no offset instructions are often used to move a pointer through a table or to hold the address of a frequently used RAM or I/O location.

10.1.6 Indexed, 8-Bit Offset

Indexed, 8-bit offset instructions are two-byte instructions that can access data with variable addresses within the first 511 memory locations. The CPU adds the unsigned byte in the index register to the unsigned byte following the opcode. The sum is the conditional address of the operand. These instructions can access locations \$0000–\$01FE.

Indexed 8-bit offset instructions are useful for selecting the *k*th element in an *n*-element table. The table can begin anywhere within the first 256 memory locations and could extend as far as location 510 (\$01FE). The *k* value is typically in the index register, and the address of the beginning of the table is in the byte following the opcode.

10.1.7 Indexed, 16-Bit Offset

Indexed, 16-bit offset instructions are three-byte instructions that can access data with variable addresses at any location in memory. The CPU adds the unsigned byte in the index register to the two unsigned bytes following the opcode. The sum is the conditional address of the operand. The first byte after the opcode is the high byte of the 16-bit offset; the second byte is the low byte of the offset. These instructions can address any location in memory.

Indexed, 16-bit offset instructions are useful for selecting the kth element in an n-element table anywhere in memory.

As with direct and extended addressing the Motorola assembler determines the shortest form of indexed addressing.

10.1.8 Relative

Relative addressing is only for branch instructions. If the branch condition is true, the CPU finds the conditional branch destination by adding the signed byte following the opcode to the contents of the program counter. If the branch condition is not true, the CPU goes to the next instruction. The offset is a signed, two's complement byte that gives a branching range of -128 to $+127$ bytes from the address of the next location after the branch instruction.

When using the Motorola assembler, the programmer does not need to calculate the offset, because the assembler determines the proper offset and verifies that it is within the span of the branch.

10.2 Instruction Types

The MCU instructions fall into the following five categories:

- Register/Memory Instructions
- Read-Modify-Write Instructions
- Jump/Branch Instructions
- Bit Manipulation Instructions
- Control Instructions

10.2.1 Register/Memory Instructions

Most of these instructions use two operands. One operand is in either the accumulator or the index register. The CPU finds the other operand in memory.

[Table 10-1](#) lists the register/memory instructions.

Table 10-1. Register/Memory Instructions

Instruction	Mnemonic
Add Memory Byte and Carry Bit to Accumulator	ADC
Add Memory Byte to Accumulator	ADD
AND Memory Byte with Accumulator	AND
Bit Test Accumulator	BIT
Compare Accumulator	CMP
Compare Index Register with Memory Byte	CPX
EXCLUSIVE OR Accumulator with Memory Byte	EOR
Load Accumulator with Memory Byte	LDA
Load Index Register with Memory Byte	LDX
Multiply	MUL
OR Accumulator with Memory Byte	ORA
Subtract Memory Byte and Carry Bit from Accumulator	SBC
Store Accumulator in Memory	STA
Store Index Register in Memory	STX
Subtract Memory Byte from Accumulator	SUB

10.2.2 Read-Modify-Write Instructions

These instructions read a memory location or a register, modify its contents, and write the modified value back to the memory location or to the register. The test for negative or zero instruction (TST) is an exception to the read-modify-write sequence because it does not write a replacement value. [Table 10-2](#) lists the read-modify-write instructions.

Table 10-2. Read-Modify-Write Instructions

Instruction	Mnemonic
Arithmetic Shift Left	ASL
Arithmetic Shift Right	ASR
Clear Bit in Memory	BCLR
Set Bit in Memory	BSET
Clear	CLR
Complement (One's Complement)	COM
Decrement	DEC
Increment	INC
Logical Shift Left	LSL
Logical Shift Right	LSR
Negate (Two's Complement)	NEG
Rotate Left through Carry Bit	ROL
Rotate Right through Carry Bit	ROR
Test for Negative or Zero	TST

10.2.3 Jump/Branch Instructions

Jump instructions allow the CPU to interrupt the normal sequence of the program counter. The unconditional jump instruction (JMP) and the jump to subroutine instruction (JSR) have no register operand. Branch instructions allow the CPU to interrupt the normal sequence of the program counter when a test condition is met. If the test condition is not met, the branch is not performed. All branch instructions use relative addressing.

Bit test and branch instructions cause a branch based on the state of any readable bit in the first 256 memory locations. These three-byte instructions use a combination of direct addressing and relative addressing. The direct address of the byte to be tested is in the byte following the opcode. The third byte is the signed offset byte. The CPU finds the conditional branch destination by adding the third byte to the program counter if the specified bit tests true. The bit to be tested and

its condition (set or clear) is part of the opcode. The span of branching is from –128 to +127 from the address of the next location after the branch instruction. The CPU also transfers the tested bit to the carry/borrow bit of the condition code register. See [Table 10-3](#) lists the jump and branch instructions.

Table 10-3. Jump and Branch Instructions

Instruction	Mnemonic
Branch if Carry Bit Clear	BCC
Branch if Carry Bit Set	BCS
Branch if Equal	BEQ
Branch if Half-Carry Bit Clear	BHCC
Branch if Half-Carry Bit Set	BHCS
Branch if Higher	BHI
Branch if Higher or Same	BHS
Branch if $\overline{\text{IRQ}}$ Pin High	BIH
Branch if $\overline{\text{IRQ}}$ Pin Low	BIL
Branch if Lower	BLO
Branch if Lower or Same	BLS
Branch if Interrupt Mask Clear	BMC
Branch if Minus	BMI
Branch if Interrupt Mask Set	BMS
Branch if Not Equal	BNE
Branch if Plus	BPL
Branch Always	BRA
Branch if Bit Clear	BRCLR
Branch Never	BRN
Branch if Bit Set	BRSET
Branch to Subroutine	BSR
Unconditional Jump	JMP
Jump to Subroutine	JSR

10.2.4 Bit Manipulation Instructions

The CPU can set or clear any writable bit in the first 256 bytes of memory. Port registers, port data direction registers, timer registers, and on-chip RAM locations are in the first 256 bytes of memory. The CPU can also test and branch based on the state of any bit in any of the first 256 memory locations. Bit manipulation instructions use direct addressing. [Table 10-4](#) lists these instructions.

Table 10-4. Bit Manipulation Instructions

Instruction	Mnemonic
Clear Bit	BCLR
Branch if Bit Clear	BRCLR
Branch if Bit Set	BRSET
Set Bit	BSET

10.2.5 Control Instructions

These register reference instructions control CPU operation during program execution. Control instructions, listed in [Table 10-5](#), use inherent addressing.

Table 10-5. Control Instructions

Instruction	Mnemonic
Clear Carry Bit	CLC
Clear Interrupt Mask	CLI
No Operation	NOP
Reset Stack Pointer	RSP
Return from Interrupt	RTI
Return from Subroutine	RTS
Set Carry Bit	SEC
Set Interrupt Mask	SEI
Stop Oscillator and Enable $\overline{\text{IRQ}}$ Pin	STOP
Software Interrupt	SWI
Transfer Accumulator to Index Register	TAX
Transfer Index Register to Accumulator	TXA
Stop CPU Clock and Enable Interrupts	WAIT

10.3 Instruction Set Summary

Table 10-6 is an alphabetical list of all M68HC05 instructions and shows the effect of each instruction on the condition code register.

Table 10-6. Instruction Set Summary

Source Form	Operation	Description	Effect on CCR					Address Mode	Opcode	Operand	Cycles
			H	I	N	Z	C				
ADC #opr ADC opr ADC opr ADC opr,X ADC opr,X ADC ,X	Add with Carry	$A \leftarrow (A) + (M) + (C)$	↑	—	↑	↑	↑	IMM DIR EXT IX2 IX1 IX	A9 B9 C9 D9 E9 F9	ii dd hh ll ee ff ff	2 3 4 5 4 3
ADD #opr ADD opr ADD opr ADD opr,X ADD opr,X ADD ,X	Add without Carry	$A \leftarrow (A) + (M)$	↑	—	↑	↑	↑	IMM DIR EXT IX2 IX1 IX	AB BB CB DB EB FB	ii dd hh ll ee ff ff	2 3 4 5 4 3
AND #opr AND opr AND opr AND opr,X AND opr,X AND ,X	Logical AND	$A \leftarrow (A) \wedge (M)$	—	—	↑	↑	—	IMM DIR EXT IX2 IX1 IX	A4 B4 C4 D4 E4 F4	ii dd hh ll ee ff ff	2 3 4 5 4 3
ASL opr ASLA ASLX ASL opr,X ASL ,X	Arithmetic Shift Left (Same as LSL)		—	—	↑	↑	↑	DIR INH INH IX1 IX	38 48 58 68 78	dd ff	5 3 3 6 5
ASR opr ASRA ASRX ASR opr,X ASR ,X	Arithmetic Shift Right		—	—	↑	↑	↑	DIR INH INH IX1 IX	37 47 57 67 77	dd ff	5 3 3 6 5
BCC rel	Branch if Carry Bit Clear	$PC \leftarrow (PC) + 2 + rel ? C = 0$	—	—	—	—	—	REL	24	rr	3
BCLR n opr	Clear Bit n	$M_n \leftarrow 0$	—	—	—	—	—	DIR (b0) DIR (b1) DIR (b2) DIR (b3) DIR (b4) DIR (b5) DIR (b6) DIR (b7)	11 13 15 17 19 1B 1D 1F	dd dd dd dd dd dd dd dd	5 5 5 5 5 5 5 5
BCS rel	Branch if Carry Bit Set (Same as BLO)	$PC \leftarrow (PC) + 2 + rel ? C = 1$	—	—	—	—	—	REL	25	rr	3
BEQ rel	Branch if Equal	$PC \leftarrow (PC) + 2 + rel ? Z = 1$	—	—	—	—	—	REL	27	rr	3

Table 10-6. Instruction Set Summary (Continued)

Source Form	Operation	Description	Effect on CCR					Address Mode	Opcode	Operand	Cycles
			H	I	N	Z	C				
BHCC <i>rel</i>	Branch if Half-Carry Bit Clear	$PC \leftarrow (PC) + 2 + rel ? H = 0$	—	—	—	—	—	REL	28	rr	3
BHCS <i>rel</i>	Branch if Half-Carry Bit Set	$PC \leftarrow (PC) + 2 + rel ? H = 1$	—	—	—	—	—	REL	29	rr	3
BHI <i>rel</i>	Branch if Higher	$PC \leftarrow (PC) + 2 + rel ? C \vee Z = 0$	—	—	—	—	—	REL	22	rr	3
BHS <i>rel</i>	Branch if Higher or Same	$PC \leftarrow (PC) + 2 + rel ? C = 0$	—	—	—	—	—	REL	24	rr	3
BIH <i>rel</i>	Branch if \overline{IRQ} Pin High	$PC \leftarrow (PC) + 2 + rel ? \overline{IRQ} = 1$	—	—	—	—	—	REL	2F	rr	3
BIL <i>rel</i>	Branch if \overline{IRQ} Pin Low	$PC \leftarrow (PC) + 2 + rel ? \overline{IRQ} = 0$	—	—	—	—	—	REL	2E	rr	3
BIT # <i>opr</i> BIT <i>opr</i> BIT <i>opr</i> ,X BIT <i>opr</i> ,X BIT ,X	Bit Test Accumulator with Memory Byte	(A) \wedge (M)	—	—	↑	↓	—	IMM DIR EXT IX2 IX1 IX	A5 B5 C5 D5 E5 F5	ii dd hh ll ee ff ff p	2 3 4 5 4 3
BLO <i>rel</i>	Branch if Lower (Same as BCS)	$PC \leftarrow (PC) + 2 + rel ? C = 1$	—	—	—	—	—	REL	25	rr	3
BLS <i>rel</i>	Branch if Lower or Same	$PC \leftarrow (PC) + 2 + rel ? C \vee Z = 1$	—	—	—	—	—	REL	23	rr	3
BMC <i>rel</i>	Branch if Interrupt Mask Clear	$PC \leftarrow (PC) + 2 + rel ? I = 0$	—	—	—	—	—	REL	2C	rr	3
BMI <i>rel</i>	Branch if Minus	$PC \leftarrow (PC) + 2 + rel ? N = 1$	—	—	—	—	—	REL	2B	rr	3
BMS <i>rel</i>	Branch if Interrupt Mask Set	$PC \leftarrow (PC) + 2 + rel ? I = 1$	—	—	—	—	—	REL	2D	rr	3
BNE <i>rel</i>	Branch if Not Equal	$PC \leftarrow (PC) + 2 + rel ? Z = 0$	—	—	—	—	—	REL	26	rr	3
BPL <i>rel</i>	Branch if Plus	$PC \leftarrow (PC) + 2 + rel ? N = 0$	—	—	—	—	—	REL	2A	rr	3
BRA <i>rel</i>	Branch Always	$PC \leftarrow (PC) + 2 + rel ? 1 = 1$	—	—	—	—	—	REL	20	rr	3
BRCLR <i>n opr rel</i>	Branch if bit n clear	$PC \leftarrow (PC) + 2 + rel ? Mn = 0$	—	—	—	—	↑	DIR (b0) DIR (b1) DIR (b2) DIR (b3) DIR (b4) DIR (b5) DIR (b6) DIR (b7)	01 03 05 07 09 0B 0D 0F	dd rr dd rr dd rr dd rr dd rr dd rr dd rr dd rr	5 5 5 5 5 5 5 5
BRSET <i>n opr rel</i>	Branch if Bit n Set	$PC \leftarrow (PC) + 2 + rel ? Mn = 1$	—	—	—	—	↓	DIR (b0) DIR (b1) DIR (b2) DIR (b3) DIR (b4) DIR (b5) DIR (b6) DIR (b7)	00 02 04 06 08 0A 0C 0E	dd rr dd rr dd rr dd rr dd rr dd rr dd rr dd rr	5 5 5 5 5 5 5 5
BRN <i>rel</i>	Branch Never	$PC \leftarrow (PC) + 2 + rel ? 1 = 0$	—	—	—	—	—	REL	21	rr	3

Table 10-6. Instruction Set Summary (Continued)

Source Form	Operation	Description	Effect on CCR					Address Mode	Opcode	Operand	Cycles	
			H	I	N	Z	C					
BSET <i>n opr</i>	Set Bit <i>n</i>	$M_n \leftarrow 1$						DIR (b0)	10	dd	5	
								DIR (b1)	12	dd	5	
								DIR (b2)	14	dd	5	
								DIR (b3)	16	dd	5	
								DIR (b4)	18	dd	5	
								DIR (b5)	1A	dd	5	
								DIR (b6)	1C	dd	5	
						DIR (b7)	1E	dd	5			
BSR <i>rel</i>	Branch to Subroutine	$PC \leftarrow (PC) + 2$; push (PCL) $SP \leftarrow (SP) - 1$; push (PCH) $SP \leftarrow (SP) - 1$ $PC \leftarrow (PC) + rel$	—	—	—	—	—	REL	AD	rr	6	
CLC	Clear Carry Bit	$C \leftarrow 0$	—	—	—	—	0	INH	98		2	
CLI	Clear Interrupt Mask	$I \leftarrow 0$	—	0	—	—	—	INH	9A		2	
CLR <i>opr</i> CLRA CLR <i>X</i> CLR <i>opr,X</i> CLR <i>,X</i>	Clear Byte	$M \leftarrow \$00$						DIR	3F	dd	5	
$A \leftarrow \$00$							INH	4F			3	
$X \leftarrow \$00$			—	—	0	1	—	INH	5F		3	
$M \leftarrow \$00$								IX1	6F	ff	6	
$M \leftarrow \$00$								IX	7F		5	
CMP # <i>opr</i> CMP <i>opr</i> CMP <i>opr</i> CMP <i>opr,X</i> CMP <i>opr,X</i> CMP <i>,X</i>	Compare Accumulator with Memory Byte	$(A) - (M)$						IMM	A1	ii	2	
								DIR	B1	dd		3
						↑	↑	↑	EXT	C1	hh ll	4
									IX2	D1	ee ff	5
									IX1	E1	ff	4
									IX	F1		3
COM <i>opr</i> COMA COM <i>X</i> COM <i>opr,X</i> COM <i>,X</i>	Complement Byte (One's Complement)	$M \leftarrow (\overline{M}) = \$FF - (M)$						DIR	33	dd	5	
$A \leftarrow (\overline{A}) = \$FF - (M)$							INH	43			3	
$X \leftarrow (\overline{X}) = \$FF - (M)$			—	—	↑	↑	1	INH	53		3	
$M \leftarrow (\overline{M}) = \$FF - (M)$								IX1	63	ff	6	
$M \leftarrow (\overline{M}) = \$FF - (M)$								IX	73		5	
CPX # <i>opr</i> CPX <i>opr</i> CPX <i>opr</i> CPX <i>opr,X</i> CPX <i>opr,X</i> CPX <i>,X</i>	Compare Index Register with Memory Byte	$(X) - (M)$						IMM	A3	ii	2	
								DIR	B3	dd		3
						↑	↑	1	EXT	C3	hh ll	4
									IX2	D3	ee ff	5
									IX1	E3	ff	4
									IX	F3		3
DEC <i>opr</i> DECA DEC <i>X</i> DEC <i>opr,X</i> DEC <i>,X</i>	Decrement Byte	$M \leftarrow (M) - 1$						DIR	3A	dd	5	
$A \leftarrow (A) - 1$							INH	4A			3	
$X \leftarrow (X) - 1$			—	—	↑	↑	—	INH	5A		3	
$M \leftarrow (M) - 1$								IX1	6A	ff	6	
$M \leftarrow (M) - 1$								IX	7A		5	
EOR # <i>opr</i> EOR <i>opr</i> EOR <i>opr</i> EOR <i>opr,X</i> EOR <i>opr,X</i> EOR <i>,X</i>	EXCLUSIVE OR Accumulator with Memory Byte	$A \leftarrow (A) \oplus (M)$						IMM	A8	ii	2	
								DIR	B8	dd		3
						↑	↑	—	EXT	C8	hh ll	4
									IX2	D8	ee ff	5
									IX1	E8	ff	4
									IX	F8		3

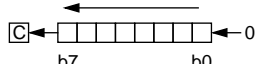
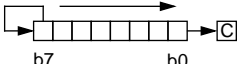
Table 10-6. Instruction Set Summary (Continued)

Source Form	Operation	Description	Effect on CCR					Address Mode	Opcode	Operand	Cycles
			H	I	N	Z	C				
INC <i>opr</i> INCA INCX INC <i>opr,X</i> INC ,X	Increment Byte	$M \leftarrow (M) + 1$ $A \leftarrow (A) + 1$ $X \leftarrow (X) + 1$ $M \leftarrow (M) + 1$ $M \leftarrow (M) + 1$			↑	↑		DIR INH INH IX1 IX	3C 4C 5C 6C 7C	dd ff	5 3 3 6 5
JMP <i>opr</i> JMP <i>opr</i> JMP <i>opr,X</i> JMP <i>opr,X</i> JMP ,X	Unconditional Jump	$PC \leftarrow \text{Jump Address}$						DIR EXT IX2 IX1 IX	BC CC DC EC FC	dd hh ll ee ff ff	2 3 4 3 2
JSR <i>opr</i> JSR <i>opr</i> JSR <i>opr,X</i> JSR <i>opr,X</i> JSR ,X	Jump to Subroutine	$PC \leftarrow (PC) + n$ ($n = 1, 2, \text{ or } 3$) Push (PCL); $SP \leftarrow (SP) - 1$ Push (PCH); $SP \leftarrow (SP) - 1$ $PC \leftarrow \text{Conditional Address}$						DIR EXT IX2 IX1 IX	BD CD DD ED FD	dd hh ll ee ff ff	5 6 7 6 5
LDA # <i>opr</i> LDA <i>opr</i> LDA <i>opr</i> LDA <i>opr,X</i> LDA <i>opr,X</i> LDA ,X	Load Accumulator with Memory Byte	$A \leftarrow (M)$			↑	↑		IMM DIR EXT IX2 IX1 IX	A6 B6 C6 D6 E6 F6	ii dd hh ll ee ff ff	2 3 4 5 4 3
LDX # <i>opr</i> LDX <i>opr</i> LDX <i>opr</i> LDX <i>opr,X</i> LDX <i>opr,X</i> LDX ,X	Load Index Register with Memory Byte	$X \leftarrow (M)$			↑	↑		IMM DIR EXT IX2 IX1 IX	AE BE CE DE EE FE	ii dd hh ll ee ff ff	2 3 4 5 4 3
LSL <i>opr</i> LSLA LSLX LSL <i>opr,X</i> LSL ,X	Logical Shift Left (Same as ASL)				↑	↑	↑	DIR INH INH IX1 IX	38 48 58 68 78	dd	5 3 3 6 5
LSR <i>opr</i> LSRA LSRX LSR <i>opr,X</i> LSR ,X	Logical Shift Right				0	↑	↑	DIR INH INH IX1 IX	34 44 54 64 74	dd ff	5 3 3 6 5
MUL	Unsigned Multiply	$X : A \leftarrow (X) \times (A)$	0				0	INH	42		11
NEG <i>opr</i> NEGA NEGX NEG <i>opr,X</i> NEG ,X	Negate Byte (Two's Complement)	$M \leftarrow -(M) = \$00 - (M)$ $A \leftarrow -(A) = \$00 - (A)$ $X \leftarrow -(X) = \$00 - (X)$ $M \leftarrow -(M) = \$00 - (M)$ $M \leftarrow -(M) = \$00 - (M)$			↑	↑	↑	DIR INH INH IX1 IX	30 40 50 60 70	ii ff	5 3 3 6 5
NOP	No Operation							INH	9D		2

Table 10-6. Instruction Set Summary (Continued)

Source Form	Operation	Description	Effect on CCR					Address Mode	Opcode	Operand	Cycles
			H	I	N	Z	C				
ORA #opr ORA opr ORA opr ORA opr,X ORA opr,X ORA ,X	Logical OR Accumulator with Memory	$A \leftarrow (A) \vee (M)$	—	—	↕	↕	—	IMM DIR EXT IX2 IX1 IX	AA BA CA DA EA FA	ii dd hh ll ee ff ff	2 3 4 5 4 3
ROL opr ROLA ROLX ROL opr,X ROL ,X	Rotate Byte Left through Carry Bit		—	—	↕	↕	↕	DIR INH INH IX1 IX	39 49 59 69 79	dd ff	5 3 3 6 5
ROR opr RORA RORX ROR opr,X ROR ,X	Rotate Byte Right through Carry Bit		—	—	↕	↕	↕	DIR INH INH IX1 IX	36 46 56 66 76	dd ff	5 3 3 6 5
RSP	Reset Stack Pointer	$SP \leftarrow \$00FF$	—	—	—	—	—	INH	9C		2
RTI	Return from Interrupt	$SP \leftarrow (SP) + 1$; Pull (CCR) $SP \leftarrow (SP) + 1$; Pull (A) $SP \leftarrow (SP) + 1$; Pull (X) $SP \leftarrow (SP) + 1$; Pull (PCH) $SP \leftarrow (SP) + 1$; Pull (PCL)	↕	↕	↕	↕	↕	INH	80		6
RTS	Return from Subroutine	$SP \leftarrow (SP) + 1$; Pull (PCH) $SP \leftarrow (SP) + 1$; Pull (PCL)	—	—	—	—	—	INH			
SBC #opr SBC opr SBC opr SBC opr,X SBC opr,X SBC ,X	Subtract Memory Byte and Carry Bit from Accumulator	$A \leftarrow (A) - (M) - (C)$	—	—	↕	↕	↕	IMM DIR EXT IX2 IX1 IX	A2 B2 C2 D2 E2 F2	ii dd hh ll ee ff ff	2 3 4 5 4 3
SEC	Set Carry Bit	$C \leftarrow 1$	—	—	—	—	1	INH	99		2
SEI	Set Interrupt Mask	$I \leftarrow 1$	—	1	—	—	—	INH	9B		2
STA opr STA opr STA opr,X STA opr,X STA ,X	Store Accumulator in Memory	$M \leftarrow (A)$	—	—	↕	↕	—	DIR EXT IX2 IX1 IX	B7 C7 D7 E7 F7	dd hh ll ee ff ff	4 5 6 5 4
STOP	Stop Oscillator and Enable \overline{IRQ} Pin		—	0	—	—	—	INH	8E		2
STX opr STX opr STX opr,X STX opr,X STX ,X	Store Index Register In Memory	$M \leftarrow (X)$	—	—	↕	↕	—	DIR EXT IX2 IX1 IX	BF CF DF EF FF	dd hh ll ee ff ff	4 5 6 5 4

Table 10-6. Instruction Set Summary (Continued)

Source Form	Operation	Description	Effect on CCR					Address Mode	Opcode	Operand	Cycles
			H	I	N	Z	C				
SUB # <i>opr</i> SUB <i>opr</i> SUB <i>opr</i> SUB <i>opr</i> , <i>X</i> SUB <i>opr</i> , <i>X</i> SUB , <i>X</i>	Subtract Memory Byte from Accumulator	$A \leftarrow (A) - (M)$	—	—	↕	↕	↕	IMM DIR EXT IX2 IX1 IX	A0 B0 C0 D0 E0 F0	ii dd hh ll ee ff ff	2 3 4 5 4 3
SWI	Software Interrupt	PC ← (PC) + 1; Push (PCL) SP ← (SP) - 1; Push (PCH) SP ← (SP) - 1; Push (X) SP ← (SP) - 1; Push (A) SP ← (SP) - 1; Push (CCR) SP ← (SP) - 1; I ← 1 PCH ← Interrupt Vector High Byte PCL ← Interrupt Vector Low Byte	—	1	—	—	—	INH	83		10
TAX	Transfer Accumulator to Index Register	$X \leftarrow (A)$	—	—	—	—	—	INH	97		2
TST <i>opr</i> TSTA TSTX TST <i>opr</i> , <i>X</i> TST , <i>X</i>	Test Memory Byte for Negative or Zero	$(M) - \$00$	—	—	—	—	—	DIR INH INH IX1 IX	3D 4D 5D 6D 7D	dd ff	4 3 3 5 4
TXA	Transfer Index Register to Accumulator	$A \leftarrow (X)$	—	—	—	—	—	INH	9F		2
WAIT	Stop CPU Clock and Enable Interrupts		—	↕	—	—	—	INH	8F		2

- | | | | |
|----------|---|------------|--------------------------------------|
| A | Accumulator | <i>opr</i> | Operand (one or two bytes) |
| C | Carry/borrow flag | PC | Program counter |
| CCR | Condition code register | PCH | Program counter high byte |
| dd | Direct address of operand | PCL | Program counter low byte |
| dd rr | Direct address of operand and relative offset of branch instruction | REL | Relative addressing mode |
| DIR | Direct addressing mode | <i>rel</i> | Relative program counter offset byte |
| ee ff | High and low bytes of offset in indexed, 16-bit offset addressing | rr | Relative program counter offset byte |
| EXT | Extended addressing mode | SP | Stack pointer |
| ff | Offset byte in indexed, 8-bit offset addressing | X | Index register |
| H | Half-carry flag | Z | Zero flag |
| hh ll | High and low bytes of operand address in extended addressing | # | Immediate value |
| I | Interrupt mask | ^ | Logical AND |
| ii | Immediate operand byte | ∨ | Logical OR |
| IMM | Immediate addressing mode | ⊕ | Logical EXCLUSIVE OR |
| INH | Inherent addressing mode | () | Contents of |
| IX | Indexed, no offset addressing mode | -() | Negation (two's complement) |
| IX1 | Indexed, 8-bit offset addressing mode | ← | Loaded with |
| IX2 | Indexed, 16-bit offset addressing mode | ? | If |
| M | Memory location | : | Concatenated with |
| N | Negative flag | ↕ | Set or cleared |
| <i>n</i> | Any bit | — | Not affected |

Table 10-7. Opcode Map

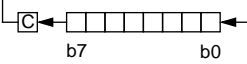
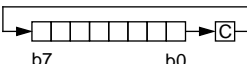
MSB LSB	Bit Manipulation		Branch	Read-Modify-Write				Control		Register/Memory						MSB LSB		
	DIR	DIR	REL	DIR	INH	INH	IX1	IX	INH	INH	IMM	DIR	EXT	IX2	IX1		IX	
	0	1	2	3	4	5	6	7	8	9	A	B	C	D	E	F		
0	BRSET0 ⁵ ₃ DIR	BSET0 ⁵ ₂ DIR	BRA ³ ₂ REL	NEG ⁵ ₁ DIR	NEGA ³ ₁ INH	NEGX ³ ₁ INH	NEG ⁶ ₂ IX1	NEG ⁵ ₁ IX	RTI ⁹ ₁ INH		SUB ² ₂ IMM	SUB ³ ₂ DIR	SUB ⁴ ₃ EXT	SUB ⁵ ₂ IX2	SUB ⁴ ₂ IX1	SUB ³ ₁ IX	0	
1	BRCLR0 ⁵ ₃ DIR	BCLR0 ⁵ ₂ DIR	BRN ³ ₂ REL						RTS ⁶ ₁ INH		CMP ² ₂ IMM	CMP ³ ₂ DIR	CMP ⁴ ₃ EXT	CMP ⁵ ₂ IX2	CMP ⁴ ₂ IX1	CMP ³ ₁ IX	1	
2	BRSET1 ⁵ ₃ DIR	BSET1 ⁵ ₂ DIR	BHI ³ ₂ REL		MUL ¹¹ ₁ INH						SBC ² ₂ IMM	SBC ³ ₂ DIR	SBC ⁴ ₃ EXT	SBC ⁵ ₂ IX2	SBC ⁴ ₂ IX1	SBC ³ ₁ IX	2	
3	BRCLR1 ⁵ ₃ DIR	BCLR1 ⁵ ₂ DIR	BLS ³ ₂ REL	COM ⁵ ₁ DIR	COMA ³ ₁ INH	COMX ³ ₁ INH	COM ⁶ ₂ IX1	COM ⁵ ₁ IX	SWI ¹⁰ ₁ INH		CPX ² ₂ IMM	CPX ³ ₂ DIR	CPX ⁴ ₃ EXT	CPX ⁵ ₂ IX2	CPX ⁴ ₂ IX1	CPX ³ ₁ IX	3	
4	BRSET2 ⁵ ₃ DIR	BSET2 ⁵ ₂ DIR	BCC ³ ₂ REL	LSR ⁵ ₂ DIR	LSRA ³ ₁ INH	LSRX ³ ₁ INH	LSR ⁶ ₂ IX1	LSR ⁵ ₁ IX			AND ² ₂ IMM	AND ³ ₂ DIR	AND ⁴ ₃ EXT	AND ⁵ ₂ IX2	AND ⁴ ₂ IX1	AND ³ ₁ IX	4	
5	BRCLR2 ⁵ ₃ DIR	BCLR2 ⁵ ₂ DIR	BCS/BLO ³ ₂ REL								BIT ² ₂ IMM	BIT ³ ₂ DIR	BIT ⁴ ₃ EXT	BIT ⁵ ₂ IX2	BIT ⁴ ₂ IX1	BIT ³ ₁ IX	5	
6	BRSET3 ⁵ ₃ DIR	BSET3 ⁵ ₂ DIR	BNE ³ ₂ REL	ROR ⁵ ₂ DIR	RORA ³ ₁ INH	RORX ³ ₁ INH	ROR ⁶ ₂ IX1	ROR ⁵ ₁ IX			LDA ² ₂ IMM	LDA ³ ₂ DIR	LDA ⁴ ₃ EXT	LDA ⁵ ₂ IX2	LDA ⁴ ₂ IX1	LDA ³ ₁ IX	6	
7	BRCLR3 ⁵ ₃ DIR	BCLR3 ⁵ ₂ DIR	BEQ ³ ₂ REL	ASR ⁵ ₂ DIR	ASRA ³ ₁ INH	ASRX ³ ₁ INH	ASR ⁶ ₂ IX1	ASR ⁵ ₁ IX	TAX ² ₁ INH			STA ⁴ ₂ DIR	STA ⁵ ₃ EXT	STA ⁶ ₂ IX2	STA ⁵ ₂ IX1	STA ⁴ ₁ IX	7	
8	BRSET4 ⁵ ₃ DIR	BSET4 ⁵ ₂ DIR	BHCC ³ ₂ REL	ASL/LSL ⁵ ₂ DIR	ASLA/LSLA ³ ₁ INH	ASLX/LSLX ³ ₁ INH	ASL/LSL ⁶ ₂ IX1	ASL/LSL ⁵ ₁ IX			CLC ² ₁ INH	EOR ² ₂ IMM	EOR ³ ₂ DIR	EOR ⁴ ₃ EXT	EOR ⁵ ₂ IX2	EOR ⁴ ₂ IX1	EOR ³ ₁ IX	8
9	BRCLR4 ⁵ ₃ DIR	BCLR4 ⁵ ₂ DIR	BHCS ³ ₂ REL	ROL ⁵ ₂ DIR	ROLA ³ ₁ INH	ROLX ³ ₁ INH	ROL ⁶ ₂ IX1	ROL ⁵ ₁ IX			SEC ² ₁ INH	ADC ² ₂ IMM	ADC ³ ₂ DIR	ADC ⁴ ₃ EXT	ADC ⁵ ₂ IX2	ADC ⁴ ₂ IX1	ADC ³ ₁ IX	9
A	BRSET5 ⁵ ₃ DIR	BSET5 ⁵ ₂ DIR	BPL ³ ₂ REL	DEC ⁵ ₂ DIR	DECA ³ ₁ INH	DECX ³ ₁ INH	DEC ⁶ ₂ IX1	DEC ⁵ ₁ IX			CLI ² ₁ INH	ORA ² ₂ IMM	ORA ³ ₂ DIR	ORA ⁴ ₃ EXT	ORA ⁵ ₂ IX2	ORA ⁴ ₂ IX1	ORA ³ ₁ IX	A
B	BRCLR5 ⁵ ₃ DIR	BCLR5 ⁵ ₂ DIR	BMI ³ ₂ REL								SEI ² ₁ INH	ADD ² ₂ IMM	ADD ³ ₂ DIR	ADD ⁴ ₃ EXT	ADD ⁵ ₂ IX2	ADD ⁴ ₂ IX1	ADD ³ ₁ IX	B
C	BRSET6 ⁵ ₃ DIR	BSET6 ⁵ ₂ DIR	BMC ³ ₂ REL	INC ⁵ ₂ DIR	INCA ³ ₁ INH	INCX ³ ₁ INH	INC ⁶ ₂ IX1	INC ⁵ ₁ IX			RSP ² ₁ INH		JMP ² ₂ DIR	JMP ³ ₃ EXT	JMP ⁴ ₂ IX2	JMP ³ ₂ IX1	JMP ² ₁ IX	C
D	BRCLR6 ⁵ ₃ DIR	BCLR6 ⁵ ₂ DIR	BMS ³ ₂ REL	TST ⁴ ₂ DIR	TSTA ³ ₁ INH	TSTX ³ ₁ INH	TST ⁵ ₂ IX1	TST ⁴ ₁ IX			NOP ² ₁ INH	BSR ⁶ ₂ REL	JSR ⁵ ₂ DIR	JSR ⁶ ₃ EXT	JSR ⁷ ₂ IX2	JSR ⁶ ₂ IX1	JSR ⁵ ₁ IX	D
E	BRSET7 ⁵ ₃ DIR	BSET7 ⁵ ₂ DIR	BIL ³ ₂ REL						STOP ² ₁ INH		LDX ² ₂ IMM	LDX ³ ₂ DIR	LDX ⁴ ₃ EXT	LDX ⁵ ₂ IX2	LDX ⁴ ₂ IX1	LDX ³ ₁ IX	E	
F	BRCLR7 ⁵ ₃ DIR	BCLR7 ⁵ ₂ DIR	BIH ³ ₂ REL	CLR ⁵ ₂ DIR	CLRA ³ ₁ INH	CLR ³ ₁ INH	CLR ⁶ ₂ IX1	CLR ⁵ ₁ IX	WAIT ² ₁ INH	TXA ² ₁ INH		STX ⁴ ₂ DIR	STX ⁵ ₃ EXT	STX ⁶ ₂ IX2	STX ⁵ ₂ IX1	STX ⁴ ₁ IX	F	

INH = Inherent
 IMM = Immediate
 DIR = Direct
 EXT = Extended
 REL = Relative
 IX = Indexed, No Offset
 IX1 = Indexed, 8-Bit Offset
 IX2 = Indexed, 16-Bit Offset

MSB
 LSB
 0
 MSB of Opcode in Hexadecimal
 Number of Cycles
 Opcode Mnemonic
 Number of Bytes/Addressing Mode

SECTION 11 ELECTRICAL SPECIFICATIONS

This section contains parametric and timing information.

11.1 Maximum Ratings

The MCU contains circuitry that protects the inputs against damage from high static voltages; however, do not apply voltages higher than those shown in [Table 11-1](#). Keep V_{in} and V_{out} within the range $V_{SS} \leq (V_{in} \text{ or } V_{out}) \leq V_{DD}$. Connect unused inputs to the appropriate logical voltage level, either V_{SS} or V_{DD} .

Table 11-1. Maximum Ratings

Rating	Symbol	Value	Unit
Supply Voltage	V_{DD}	-0.3 to +7.0	V
Input Voltage All Pins in Normal Operation \overline{IRQ}/V_{PP} Pin in Bootloader Mode	V_{in}	$V_{SS} - 0.3$ to $V_{DD} + 0.3$ $V_{SS} - 0.3$ to $2 \times V_{DD} + 0.3$	V
EPROM Programming Voltage (\overline{IRQ}/V_{PP} Pin)	V_{PP}	16.75	V
Current Drain Per Pin (Excluding V_{DD} and V_{SS})	I	25	mA
Operating Temperature Range MC68HC705J2P, DW (Standard) MC68HC705J2CP, CDW (Extended) MC68HC705J2VP, VDW	T_A	0 to +70 -40 to +85 -40 to +105	°C
Storage Temperature Range	T_{STG}	-65 to +150	°C

11.2 Thermal Characteristics

Table 11-2. Thermal Resistance

Characteristic	Symbol	Value	Unit
Thermal Resistance PDIP SOIC	θ_{JA}	60 60	°C/W

11.3 Power Considerations

The average chip-junction temperature, T_J , in °C, can be obtained from:

$$T_J = T_A + (P_D \times \theta_{JA}) \quad (1)$$

where:

T_A = Ambient temperature, °C

θ_{JA} = Package thermal resistance, junction to ambient, °C/W

$P_D = P_{INT} + P_{I/O}$

$P_{INT} = I_{DD} \times V_{DD}$ watts (chip internal power)

$P_{I/O}$ = Power dissipation on input and output pins (user-determined)

For most applications $P_{I/O} \ll P_{INT}$ and can be neglected.

The following is an approximate relationship between P_D and T_J (neglecting $P_{I/O}$):

$$P_D = K \div (T_J + 273 \text{ °C}) \quad (2)$$

Solving equations (1) and (2) for K gives:

$$K = P_D \times (T_A + 273 \text{ °C}) + \theta_{JA} \times (P_D)^2 \quad (3)$$

where K is a constant pertaining to the particular part. K can be determined from equation (3) by measuring P_D (at equilibrium) for a known T_A . Using this value of K, the values of P_D and T_J can be obtained by solving equations (1) and (2) iteratively for any value of T_A .

11.4 DC Electrical Characteristics ($V_{DD} = 5.0$ Vdc)

Table 11-3. DC Electrical Characteristics ($V_{DD} = 5.0$ Vdc)

Characteristic	Symbol	Min	Typ	Max	Unit
Output Voltage $I_{load} = 10.0 \mu A$ $I_{load} = -10.0 \mu A$	V_{OL} V_{OH}	— $V_{DD} - 0.1$	— —	0.1 —	V
Output High Voltage ($I_{load} = -0.8$ mA) PA7–PA0, PB5–PB0	V_{OH}	$V_{DD} - 0.8$	—	—	V
Output Low Voltage ($I_{load} = 1.6$ mA) PA7–PA0, PB5–PB0	V_{OL}	—	—	0.4	V
Input High Voltage PA7–PA0, PB5–PB0, \overline{IRQ}/V_{PP} , \overline{RESET} , OSC1	V_{IH}	$0.7 \times V_{DD}$	—	V_{DD}	V
Input Low Voltage PA7–PA0, PB5–PB0, \overline{IRQ}/V_{PP} , \overline{RESET} , OSC1	V_{IL}	V_{SS}	—	$0.2 \times V_{DD}$	V
Supply Current (See NOTES.)					
Run	I_{DD}	—	5.0	7.0	mA
Wait		—	1.3	2.5	mA
Stop		—	2.0	30	μA
25 °C –40 to +85 °C		— —	— —	100	μA
I/O Ports High-Z Leakage Current PA7–PA0, PB5–PB0	I_{OZ}	—	—	10	μA
Input Current \overline{RESET} , \overline{IRQ}/V_{PP} , OSC1	I_{in}	—	—	± 1	μA
Capacitance					
Ports (as input or output)	C_{out}	—	—	12	pF
\overline{RESET} , \overline{IRQ}/V_{PP}	C_{in}	—	—	8	
Programming Voltage	V_{PP}	16.25	16.5	16.75	V
Programming Current	I_{PP}	—	5	10	mA
Programming Time/Byte	t_{EPGM}	4	—	—	ms

NOTES:

1. Typical values at midpoint of voltage range, 25 °C only.
2. Run (operating) I_{DD} and wait I_{DD} measured using external square wave clock source ($f_{osc} = 4.2$ MHz), all inputs 0.2 V from rail; no dc loads; less than 50 pF on all outputs; $C_L = 20$ pF on OSC2.
3. Wait I_{DD} and Stop I_{DD} : all ports configured as inputs; $V_{IL} = 0.2$ V, $V_{IH} = V_{DD} - 0.2$ V.
4. Stop I_{DD} measured with OSC1 = V_{SS} .
5. Standard temperature range is 0 °C to 70 °C.
6. OSC2 capacitance linearly affects Wait I_{DD} .
7. Programming voltage measured at \overline{IRQ}/V_{PP} pin.

11.5 DC Electrical Characteristics ($V_{DD} = 3.3 \text{ Vdc}$)

Table 11-4. DC Electrical Characteristics ($V_{DD} = 3.3 \text{ Vdc}$)

Characteristic	Symbol	Min	Typ	Max	Unit
Output Voltage $I_{load} = 10.0 \mu\text{A}$ $I_{load} = -10.0 \mu\text{A}$	V_{OL} V_{OH}	— $V_{DD} - 0.1$	— —	0.1 —	V
Output High Voltage ($I_{load} = -0.2 \text{ mA}$) PA7-PA0, PB5-PB0	V_{OH}	$V_{DD} - 0.3$	—	—	V
Output Low Voltage ($I_{load} = 0.4 \text{ mA}$) PA7-PA0, PB5-PB0	V_{OL}	—	—	0.3	V
Input High Voltage PA7-PA0, PB5-PB0, $\overline{\text{IRQ}}/V_{PP}$, $\overline{\text{RESET}}$, OSC1	V_{IH}	$0.7 \times V_{DD}$	—	V_{DD}	V
Input Low Voltage PA7-PA0, PB5-PB0, $\overline{\text{IRQ}}/V_{PP}$, $\overline{\text{RESET}}$, OSC1	V_{IL}	V_{SS}	—	$0.2 \times V_{DD}$	V
Supply Current (See NOTES.)					
Run	I_{DD}	—	1.3	2.0	mA
Wait		—	0.7	1.0	mA
Stop		—	—	—	—
25 °C		—	1.0	20	μA
-40 to +85 °C	—	—	—	50	μA
I/O Ports High-Z Leakage Current PA7-PA0, PB5-PB0	I_{oz}	—	—	± 10	μA
Input Current $\overline{\text{RESET}}$, $\overline{\text{IRQ}}/V_{PP}$, OSC1	I_{in}	—	—	± 1	μA
Capacitance					
Ports (as input or output)	C_{out}	—	—	12	pF
$\overline{\text{RESET}}$, $\overline{\text{IRQ}}/V_{PP}$	C_{in}	—	—	8	pF

NOTES:

1. Typical values at midpoint of voltage range, 25 °C only.
2. Run (operating) I_{DD} and Wait I_{DD} measured using external square wave clock source ($f_{osc} = 2 \text{ MHz}$), all inputs 0.2 V from rail; no dc loads; less than 50 pF on all outputs; $C_L = 20 \text{ pF}$ on OSC2.
3. Wait I_{DD} and Stop I_{DD} : all ports configured as inputs; $V_{IL} = 0.2 \text{ V}$, $V_{IH} = V_{DD} - 0.2 \text{ V}$.
4. Stop I_{DD} measured with $\text{OSC1} = V_{SS}$.
5. Standard temperature range is 0 °C to 70 °C.
6. OSC2 capacitance linearly affects Wait I_{DD} .

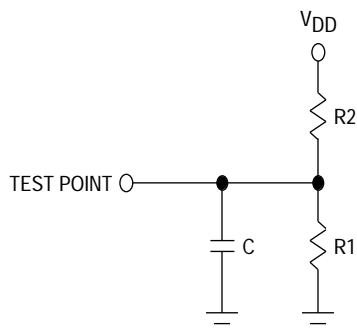

PINS	V_{DD}	R1	R2	C
PA7-PA0, PB5-PB0	4.5 V	3.26 k	2.38 k	50 pF
	3.0 V	10.91 k	6.32 k	50 pF

Figure 11-1. Equivalent Test Load

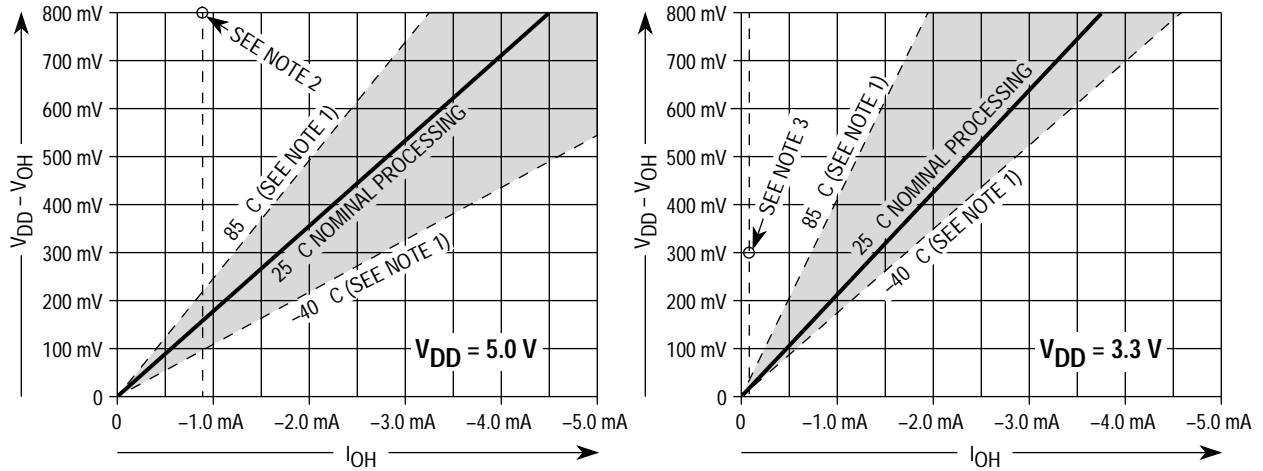

NOTES:

1. Shaded area indicates variation in driver characteristics due to changes in temperature and for normal processing tolerances. Within the limited range of values shown, V vs I curves are approximately straight lines.
2. At $V_{DD} = 5.0\text{ V}$, devices are specified and tested for $(V_{DD} - V_{OH})$ 800 mV @ $b_L = -0.8\text{ mA}$.
3. At $V_{DD} = 3.3\text{ V}$, devices are specified and tested for $(V_{DD} - V_{OH})$ 300 mV @ $b_L = -0.2\text{ mA}$.

Figure 11-2. Typical High-Side Driver Characteristics

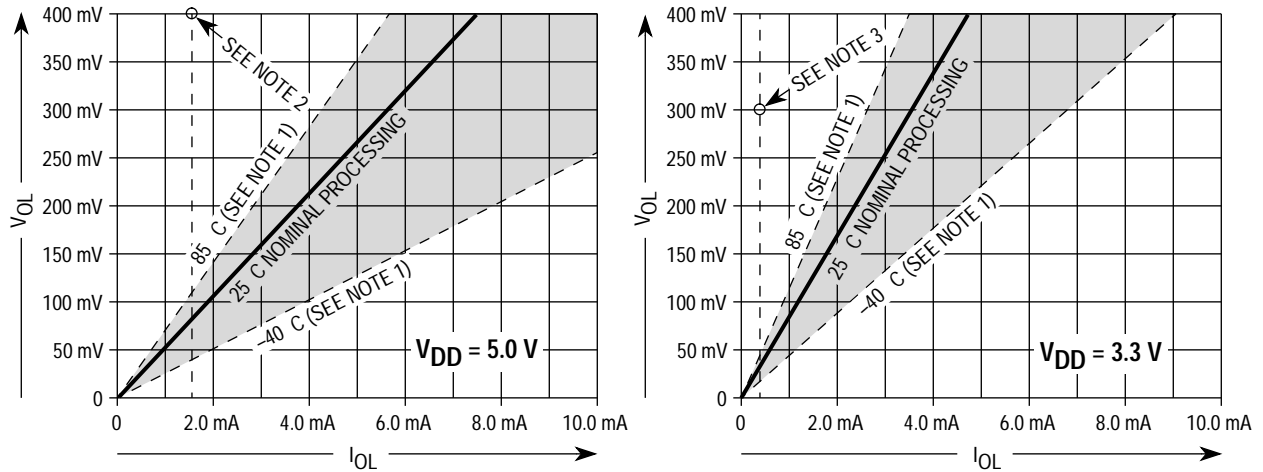

NOTES:

1. Shaded area indicates variation in driver characteristics due to changes in temperature and for normal processing tolerances. Within the limited range of values shown, V vs I curves are approximately straight lines.
2. At $V_{DD} = 5.0\text{ V}$, devices are specified and tested for V_{OL} 400 mV @ $b_L = 1.6\text{ mA}$.
3. At $V_{DD} = 3.3\text{ V}$, devices are specified and tested for V_{OL} 300 mV @ $b_L = 0.4\text{ mA}$.

Figure 11-3. Typical Low-Side Driver Characteristics

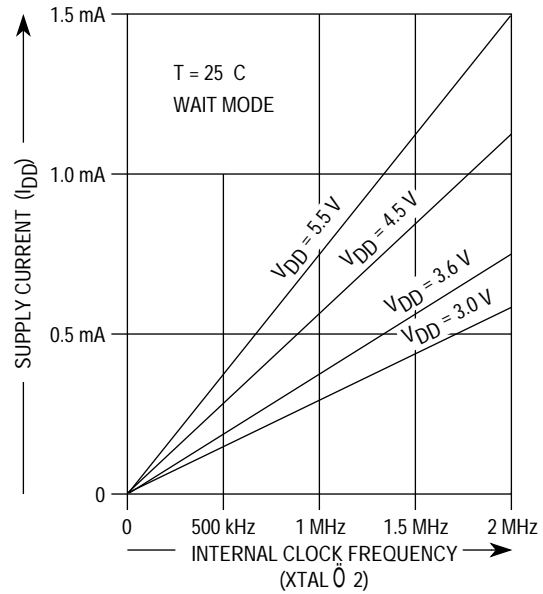
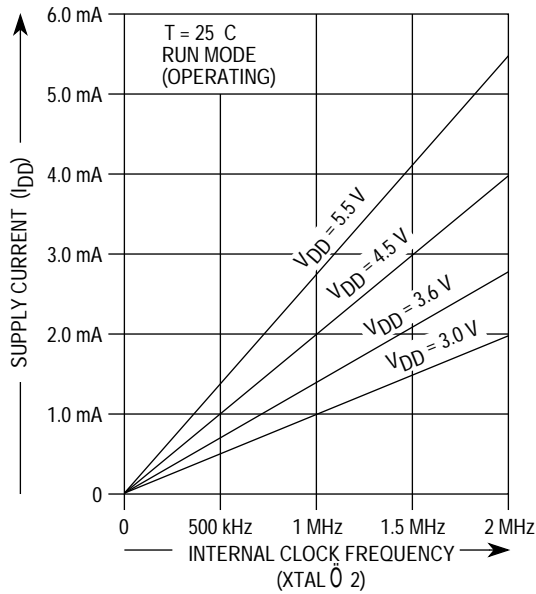
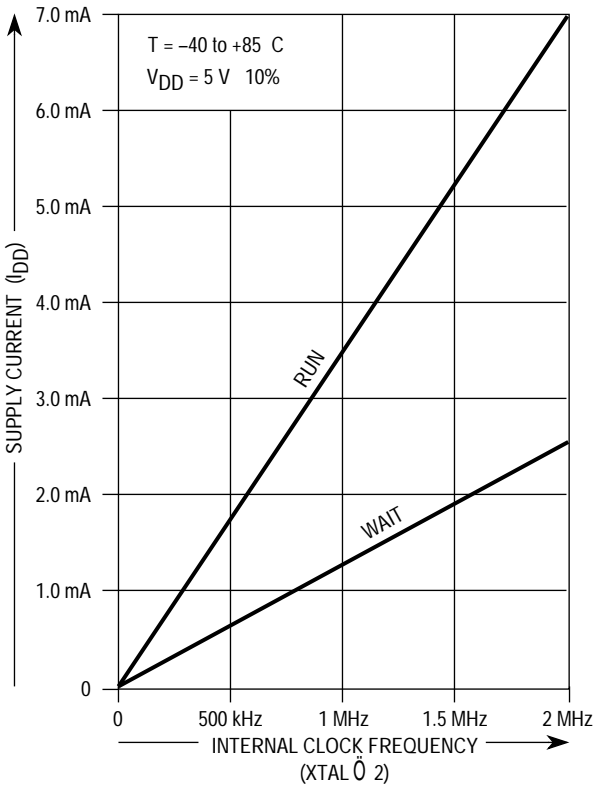
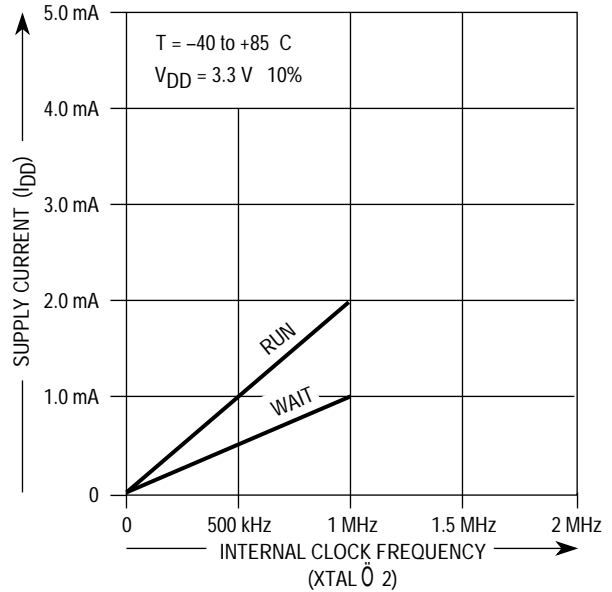

Figure 11-4. Typical Supply Current vs Clock Frequency



NOTE: Maximum STOP I_{DD} = 100 μA when V_{DD} = 5 V.



NOTE: Maximum STOP I_{DD} = 50 μA when V_{DD} = 3 V.

Figure 11-5. Maximum Supply Current vs Clock Frequency

11.6 Control Timing ($V_{DD} = 5.0 \text{ Vdc}$)

Table 11-5. Control Timing ($V_{DD} = 5.0 \text{ Vdc}$)

($V_{DD} = 5.0 \text{ Vdc}$ 10%, $V_{SS} = 0 \text{ Vdc}$; $T_A = T_L$ to T_H)

Characteristic	Symbol	Min	Max	Unit
Oscillator Frequency Crystal Option External Clock Option	f_{osc}	— dc	4.2 4.2	MHz
Internal Operating Frequency Crystal ($f_{osc} \div 2$) External Clock ($f_{osc} \div 2$)	f_{op}	— dc	2.1 2.1	MHz
Cycle Time	t_{cyc}	480	—	ns
RESET Pulse Width	t_{RL}	1.5	—	t_{cyc}
Timer Resolution (NOTE 1)	t_{RESL}	4.0	—	t_{cyc}
Interrupt Pulse Width Low (Edge-Triggered)	t_{ILIH}	125	—	ns
Interrupt Pulse Period	t_{ILIL}	(NOTE 2)	—	t_{cyc}
OSC1 Pulse Width	t_{OH}, t_{OL}	90	—	ns
Programming Time per Byte	t_{EPGM}	4	—	ms

NOTES:

1. The 2-bit timer prescaler is the limiting factor in determining timer resolution.
2. The minimum period t_{ILIL} should not be less than the number of cycle times it takes to execute the interrupt service routine plus $19 t_{cyc}$.

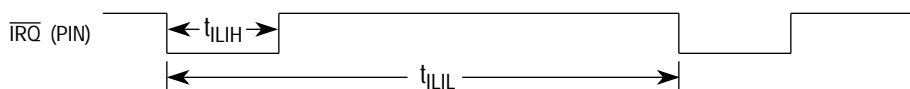

Edge-Sensitive Trigger — The minimum t_{ILIH} is either 125 ns ($V_{DD} = 5 \text{ V}$) or 250 ns ($V_{DD} = 3 \text{ V}$). The period t_{ILIL} should not be less than the number of t_{cyc} cycles it takes to execute the interrupt service routine plus $19 t_{cyc}$ cycles.

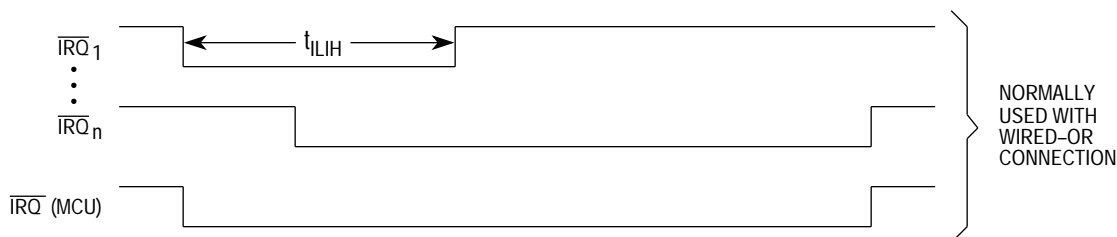

Edge and Level-Sensitive Trigger — If IRQ remains low after interrupt is serviced, the next interrupt is recognized.

Figure 11-6. External Interrupt Timing

11.7 Control Timing ($V_{DD} = 3.3 \text{ Vdc}$)

Table 11-6. Control Timing ($V_{DD} = 3.3 \text{ Vdc}$)

($V_{DD} = 3.3 \text{ Vdc}$ 10%, $V_{SS} = 0 \text{ Vdc}$; $T_A = T_L$ to T_H)

Characteristic	Symbol	Min	Max	Unit
Oscillator Frequency Crystal Option External Clock Option	f_{osc}	— dc	2.0 2.0	MHz
Internal Operating Frequency Crystal ($f_{osc} \div 2$) External Clock ($f_{osc} \div 2$)	f_{op}	— dc	1.0 1.0	MHz
Cycle Time	t_{cyc}	1000	—	ns
$\overline{\text{RESET}}$ Pulse Width	t_{RL}	1.5	—	t_{cyc}
Timer Resolution (NOTE 1)	t_{RESL}	4.0	—	t_{cyc}
Interrupt Pulse Width Low (Edge-Triggered)	t_{LIH}	250	—	ns
Interrupt Pulse Period	t_{LIL}	(NOTE 2)	—	t_{cyc}
OSC1 Pulse Width	t_{OH}, t_{OL}	400	—	ns

NOTES:

1. The 2-bit timer prescaler is the limiting factor in determining timer resolution.
2. The minimum period t_{LIL} should not be less than the number of cycle times it takes to execute the interrupt service routine plus 19 t_{cyc} .

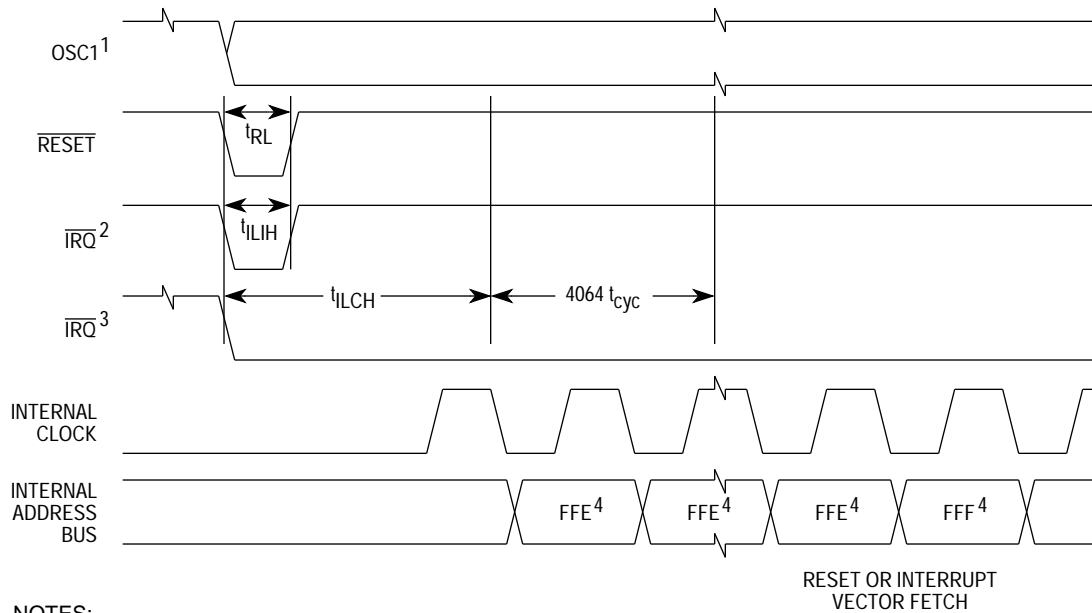

NOTES:

1. Represents internal gating of OSC1 pin.
2. \overline{IRQ} pin edge-sensitive mask option.
3. \overline{IRQ} pin level and edge-sensitive mask option.
4. Reset vector address of MC68HC705J2 native mode shown as timing example.

Figure 11-7. STOP Recovery Timing

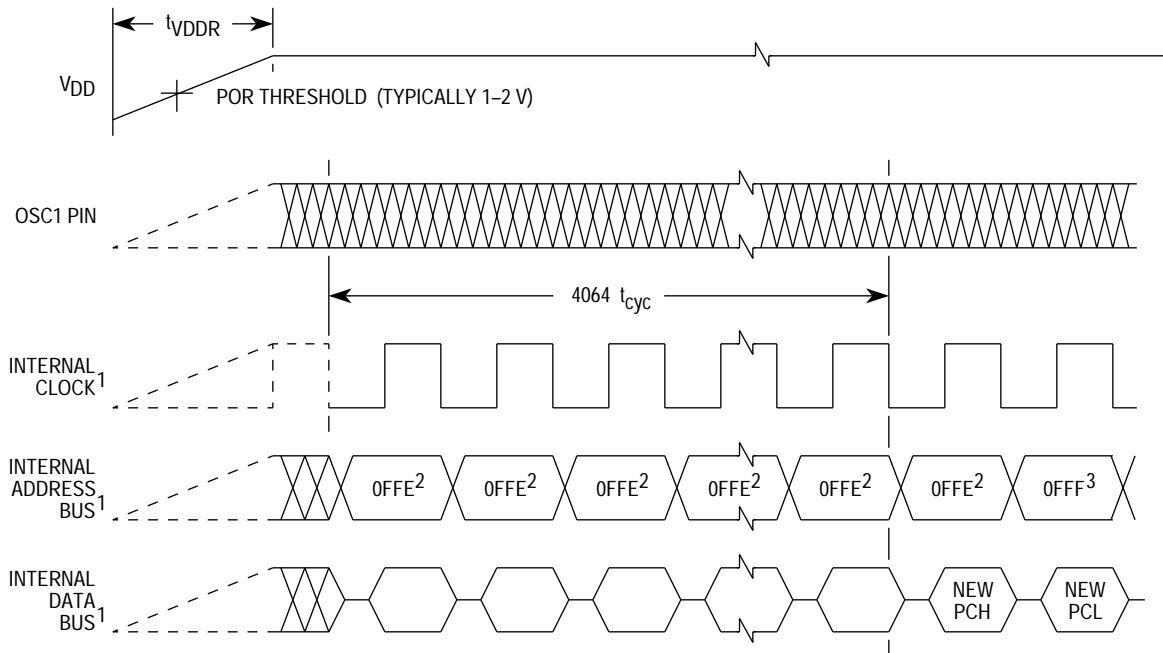

NOTES:

1. Internal clock, internal address bus, and internal data bus are not available externally.
2. Address of high byte of reset vector is \$0FFE in MC68HC705J2 native mode and \$07FE in MC68HC05J1 emulation mode.
3. Address of low byte of reset vector is \$0FFF in MC68HC705J2 native mode and \$07FF in MC68HC05J1 emulation mode.

Figure 11-8. Power-On Reset Timing

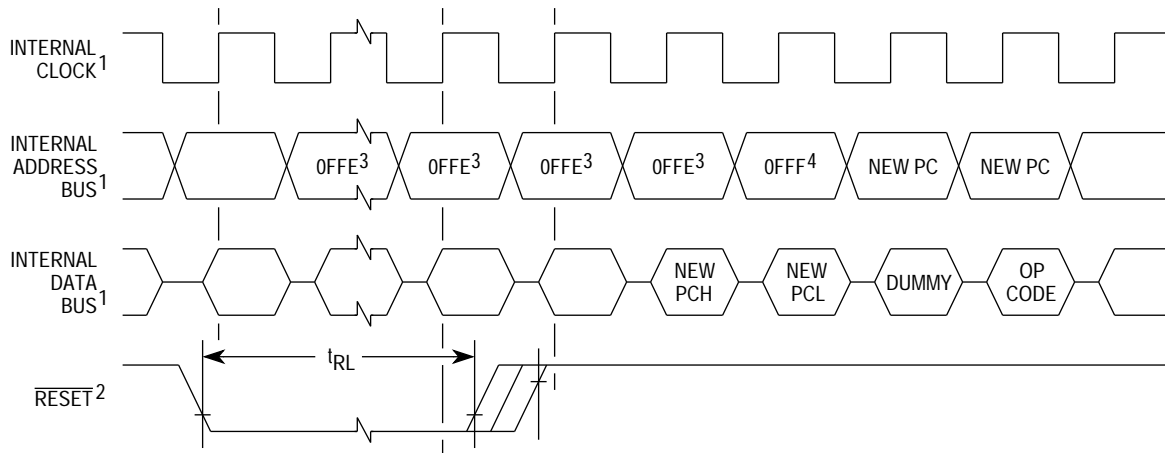

NOTES:

1. Internal clock, internal address bus, and internal data bus signals are not available externally.
2. Next rising edge of internal clock after rising edge of $\overline{\text{RESET}}$ initiates reset sequence.
3. Address of high byte of reset vector is \$0FFE in MC68HC705J2 native mode and \$07FE in MC68HC05J1 emulation mode.
4. Address of low byte of reset vector is \$0FFF in MC68HC705J2 native mode and \$07FF in MC68HC05J1 emulation mode.

Figure 11-9. External Reset Timing

SECTION 12 MECHANICAL SPECIFICATIONS

The MC68HC705J2 is available in the following packages:

- 738-03 — plastic dual in-line package (PDIP)
- 751D-04 — small outline integrated circuit (SOIC)
- 732-03 — ceramic DIP (Cerdip) (windowed)

The following figures show the latest packages at the time of this publication. To make sure that you have the latest package specifications, contact one of the following:

- Local Motorola Sales Office
- Motorola Mfax
 - Phone 602-244-6609
 - EMAIL rmfax0@email.sps.mot.com
- Worldwide Web (wwweb) at <http://design-net.com>

Follow Mfax or Worldwide Web on-line instructions to retrieve the current mechanical specifications.

12.1 Plastic Dual In-Line Package (DIP)

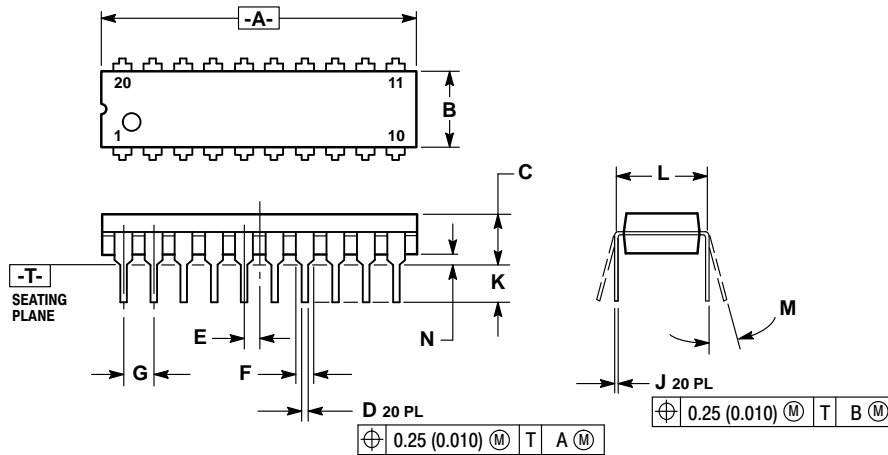

NOTES:

1. DIMENSIONING AND TOLERANCING PER ANSI Y14.5M, 1982.
2. CONTROLLING DIMENSION: INCH.
3. DIMENSION L TO CENTER OF LEAD WHEN FORMED PARALLEL.
4. DIMENSION B DOES NOT INCLUDE MOLD FLASH.

DIM	INCHES		MILLIMETERS	
	MIN	MAX	MIN	MAX
A	1.010	1.070	25.66	27.17
B	0.240	0.260	6.10	6.60
C	0.150	0.180	3.81	4.57
D	0.015	0.022	0.39	0.55
E	0.050 BSC		1.27 BSC	
F	0.050	0.070	1.27	1.77
G	0.100 BSC		2.54 BSC	
J	0.008	0.015	0.21	0.38
K	0.110	0.140	2.80	3.55
L	0.300 BSC		7.62 BSC	
M	0°	15°	0°	15°
N	0.020	0.040	0.51	1.01

Figure 12-1. MC68HC705J2P (Case 738-03)

12.2 Small Outline Integrated Circuit (SOIC)

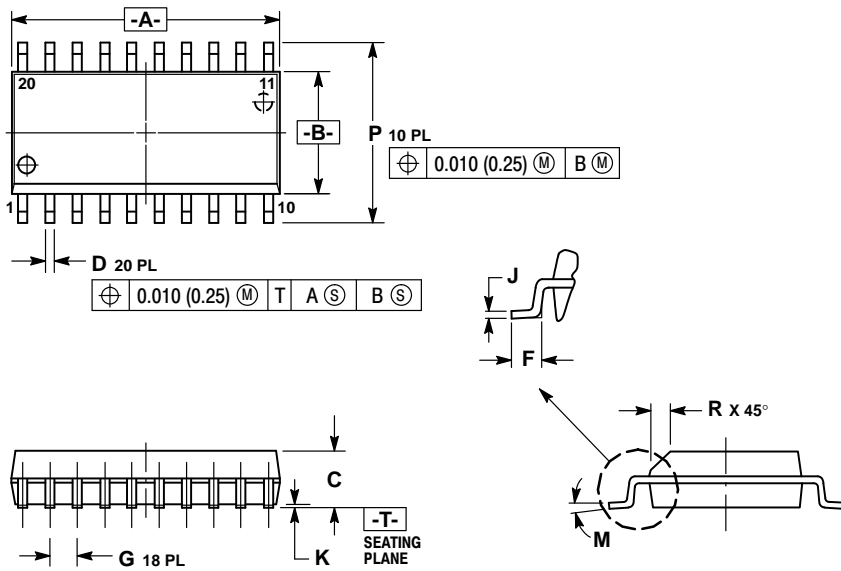

NOTES:

1. DIMENSIONING AND TOLERANCING PER ANSI Y14.5M, 1982.
2. CONTROLLING DIMENSION: MILLIMETER.
3. DIMENSIONS A AND B DO NOT INCLUDE MOLD PROTRUSION.
4. MAXIMUM MOLD PROTRUSION 0.150 (0.006) PER SIDE.
5. DIMENSION D DOES NOT INCLUDE DAMBAR PROTRUSION. ALLOWABLE DAMBAR PROTRUSION SHALL BE 0.13 (0.005) TOTAL IN EXCESS OF D DIMENSION AT MAXIMUM MATERIAL CONDITION.

DIM	MILLIMETERS		INCHES	
	MIN	MAX	MIN	MAX
A	12.65	12.95	0.499	0.510
B	7.40	7.60	0.292	0.299
C	2.35	2.65	0.093	0.104
D	0.35	0.49	0.014	0.019
F	0.50	0.90	0.020	0.035
G	1.27 BSC		0.050 BSC	
J	0.25	0.32	0.010	0.012
K	0.10	0.25	0.004	0.009
M	0°	7°	0°	7°
P	10.05	10.55	0.395	0.415
R	0.25	0.75	0.010	0.029

Figure 12-2. MC68HC705J2DW (Case 751D-04)

12.3 Ceramic DIP (Cerdip)

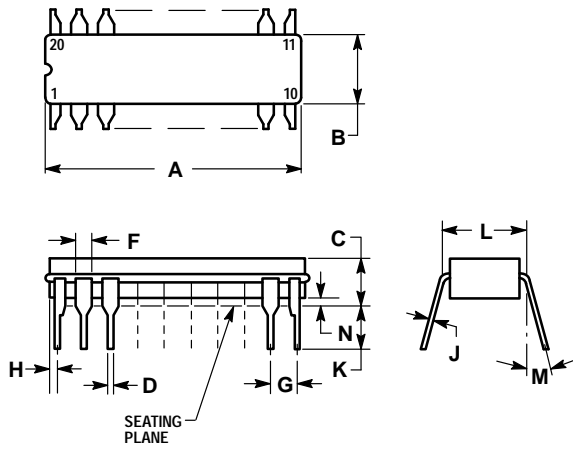

NOTES:

1. LEADS WITHIN 0.010 DIAMETER, TRUE POSITION AT SEATING PLANE, AT MAXIMUM MATERIAL CONDITION.
2. DIMENSION L TO CENTER OF LEADS WHEN FORMED PARALLEL.
3. DIMENSIONS A AND B INCLUDE MENISCUS.

DIM	INCHES	
	MIN	MAX
A	0.940	0.990
B	0.260	0.295
C	0.150	0.200
D	0.015	0.022
F	0.055	0.065
G	0.100 BSC	
H	0.020	0.050
J	0.008	0.012
K	0.125	0.160
L	0.300 BSC	
M	0° 15°	
N	0.010	0.040

Figure 12-3. MC68HC705J2S (Case 732-03)

Motorola reserves the right to make changes without further notice to any products herein. Motorola makes no warranty, representation or guarantee regarding the suitability of its products for any particular purpose, nor does Motorola assume any liability arising out of the application or use of any product or circuit, and specifically disclaims any and all liability, including without limitation consequential or incidental damages. "Typical" parameters which may be provided in Motorola data sheets and/or specifications can and do vary in different applications and actual performance may vary over time. All operating parameters, including "Typicals" must be validated for each customer application by customer's technical experts. Motorola does not convey any license under its patent rights nor the rights of others. Motorola products are not designed, intended, or authorized for use as components in systems intended for surgical implant into the body, or other applications intended to support or sustain life, or for any other application in which the failure of the Motorola product could create a situation where personal injury or death may occur. Should Buyer purchase or use Motorola products for any such unintended or unauthorized application, Buyer shall indemnify and hold Motorola and its officers, employees, subsidiaries, affiliates, and distributors harmless against all claims, costs, damages, and expenses, and reasonable attorney fees arising out of, directly or indirectly, any claim of personal injury or death associated with such unintended or unauthorized use, even if such claim alleges that Motorola was negligent regarding the design or manufacture of the part. Motorola and  are registered trademarks of Motorola, Inc. Motorola, Inc. is an Equal Opportunity/Affirmative Action Employer.

How to reach us:

USA/EUROPE/Locations Not Listed: Motorola Literature Distribution; P.O. Box 20912; Phoenix, Arizona 85036. 1-800-441-2447 or 602-303-5454

MFAX: RMFAX0@email.sps.mot.com – TOUCHTONE 602-244-6609

INTERNET: <http://Design-NET.com>

JAPAN: Nippon Motorola Ltd.; Tatsumi-SPD-JLDC, 6F Seibu-Butsuryu-Center, 3-14-2 Tatsumi Koto-Ku, Tokyo 135, Japan.
03-81-3521-8315

ASIA/PACIFIC: Motorola Semiconductors H.K. Ltd.; 8B Tai Ping Industrial Park, 51 Ting Kok Road, Tai Po, N.T., Hong Kong. 852-26629298



MOTOROLA

MC68HC705J2/D