

# FBR2500W - FBR2510W

**PRV : 50 - 1000 Volts**  
**Io : 25 Amperes**

## FEATURES :

- \* High case dielectric strength
- \* High surge current capability
- \* High reliability
- \* Low reverse current
- \* Low forward voltage drop
- \* Fast switching for high efficiency
- \* Pb / RoHS Free

## MECHANICAL DATA :

- \* Case : Molded plastic with heatsink integrally mounted in the bridge encapsulation
- \* Epoxy : UL94V-O rate flame retardant
- \* Terminals : Plated lead solderable per MIL-STD-202, Method 208 guaranteed
- \* Polarity : Polarity symbols marked on case
- \* Mounting position : Bolt down on heat-sink with silicone thermal compound between bridge and mounting surface for maximum heat transfer efficiency
- \* Weight : 15.95 grams

# FAST RECOVERY BRIDGE RECTIFIERS

## BR50W

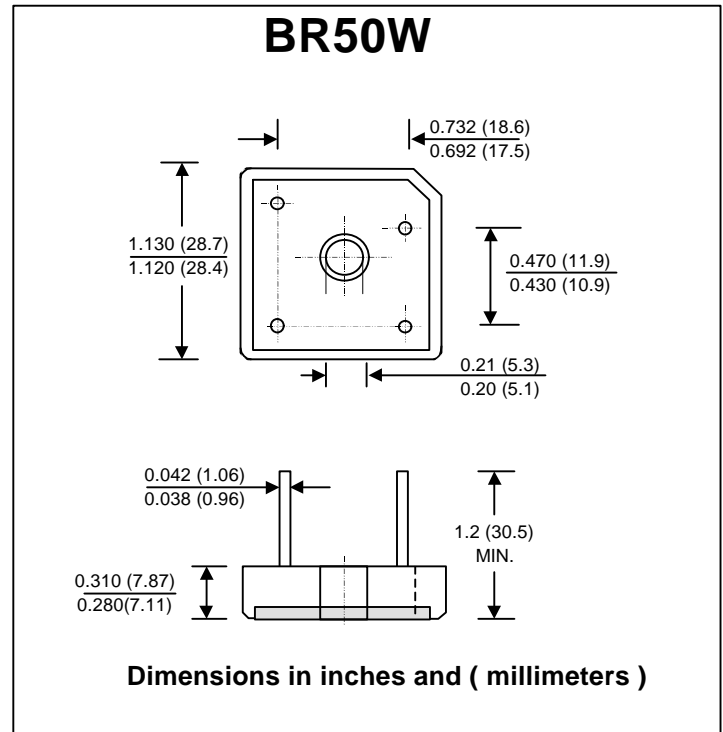

## MAXIMUM RATINGS AND ELECTRICAL CHARACTERISTICS

Rating at 25 °C ambient temperature unless otherwise specified.  
 Single phase, half wave, 60 Hz, resistive or inductive load.  
 For capacitive load, derate current by 20%.

RATING	SYMBOL	FBR 2500W	FBR 2501W	FBR 2502W	FBR 2504W	FBR 2506W	FBR 2508W	FBR 2510W	UNIT
Maximum Recurrent Peak Reverse Voltage	$V_{RRM}$	50	100	200	400	600	800	1000	V
Maximum RMS Voltage	$V_{RMS}$	35	70	140	280	420	560	700	V
Maximum DC Blocking Voltage	$V_{DC}$	50	100	200	400	600	800	1000	V
Maximum Average Forward Current $T_c = 55\text{ }^\circ\text{C}$	$I_{F(AV)}$	25							A
Peak Forward Surge Current Single half sine wave Superimposed on rated load (JEDEC Method)	$I_{FSM}$	300							A
Current Squared Time at $t < 8.3\text{ ms.}$	$I^2t$	375							A <sup>2</sup> S
Maximum Forward Voltage drop per Diode at $I_F = 12.5\text{ A}$	$V_F$	1.3							V
Maximum DC Reverse Current $T_a = 25\text{ }^\circ\text{C}$ at Rated DC Blocking Voltage $T_a = 100\text{ }^\circ\text{C}$	$I_R$	10							$\mu\text{A}$
	$I_{R(H)}$	200							$\mu\text{A}$
Maximum Reverse Recovery Time (Note 1)	$T_{rr}$	150				250	500		ns
Typical Thermal Resistance per diode (Note 2)	$R_{\theta JC}$	1.45							$^\circ\text{C/W}$
Operating Junction Temperature Range	$T_J$	- 50 to + 150							$^\circ\text{C}$
Storage Temperature Range	$T_{STG}$	- 50 to + 150							$^\circ\text{C}$

### Notes :

- 1) Measured with  $I_F = 0.5\text{ Amp.}$ ,  $I_R = 1\text{ Amp.}$ ,  $I_{rr} = 0.25\text{ Amp.}$
- 2) Thermal Resistance from junction to case with units mounted on a 5" x 6" x 4.9" (12.8cm.x 15.2cm.x 12.4cm.) Al.-Finned Plate.

## RATING AND CHARACTERISTIC CURVES ( FBR2500W - FBR2510W )

**FIG.1 - REVERSE RECOVERY TIME CHARACTERISTIC AND TEST CIRCUIT DIAGRAM**

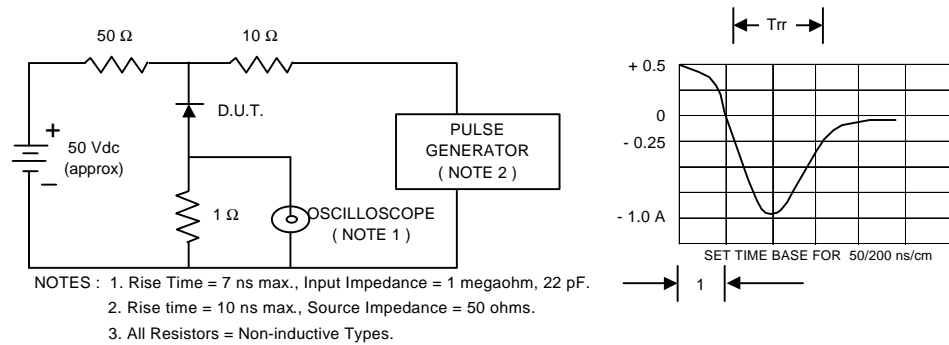

**FIG.2 - DERATING CURVE FOR OUTPUT RECTIFIED CURRENT**

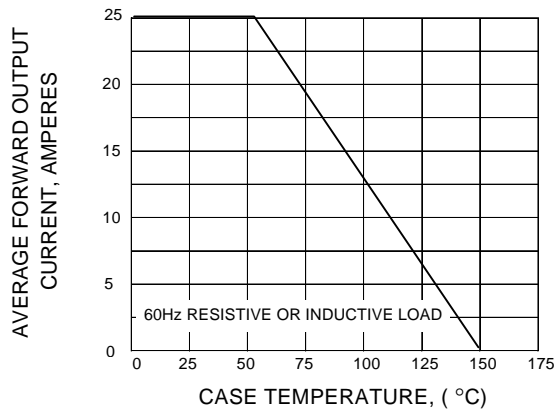

**FIG.3 - MAXIMUM NON-REPETITIVE PEAK FORWARD SURGE CURRENT**

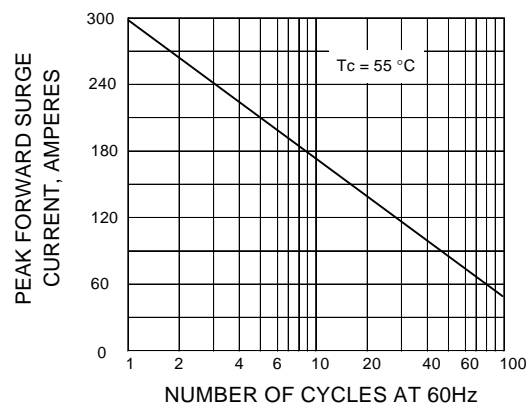

**FIG.4 - TYPICAL FORWARD CHARACTERISTICS PER DIODE**

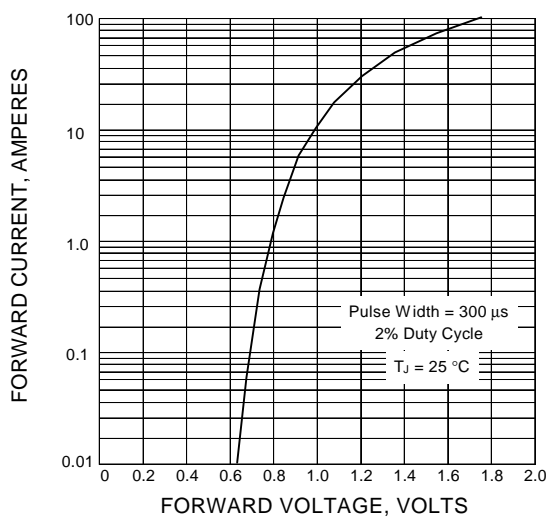

**FIG.5 - TYPICAL REVERSE CHARACTERISTICS PER DIODE**

