

### DESCRIPTION

Demonstration circuit 491 features the LTC1923EUH thermoelectric cooler (TEC) controller. The LTC1923EUH comes in a small 32-lead QFN package (5mm by 5mm). Since the switching frequency of the circuit is 1MHz, small size inductors and capacitors are used as output filters. The main components are within a small assembly area about 0.75" by 0.5". DC491 provides a complete temperature control solution for TEC based temperature control of fiber-optic lasers. Laser temperature may be controlled at temperatures above or below ambient with

set point stability typically well within 0.05°C over widely varying ambient temperature. Temperature set point is established with a potentiometer. Considerably more detail relating to TEC temperature control issues is available in LTC Application Note AN-89, *A Thermoelectric Cooler Temperature Controller for Fiber Optic Lasers*. This publication should be reviewed before demo board results are evaluated.

**Design files for this circuit board are available. Call the LTC factory.**

### QUICK START PROCEDURE

Demonstration circuit 491 is easy to set up to evaluate the performance of the LTC1923EUH. Refer to Figure 1 for proper measurement equipment setup and follow the procedure below:

1. Connect a turned-off power supply (2.7–5.5V) to the VDD and GND terminals.
2. Connect a thermistor to the NTC+ and NTC– terminals. Although the thermistor is not a polarized device, one of its leads may be committed to the lasers case ground. If this is so, this lead should be connected to NTC–. Shielded cable should be used for the thermistor leads, with the shield connected to ground.
3. Adjust the temperature set point potentiometer (R15) using a small screwdriver.
4. Connect the TEC leads from the laser to the boards TEC+ and TEC– terminals. Observe polarity.
5. Turn on the power supply. The board will typically pull hundreds of milliamps for several seconds. Once the temperature set point is reached the current drops and settles to some sustaining value.
6. Performance optimization for any particular laser is achievable by following the procedures and guidelines given in LTC Application Note AN-89.

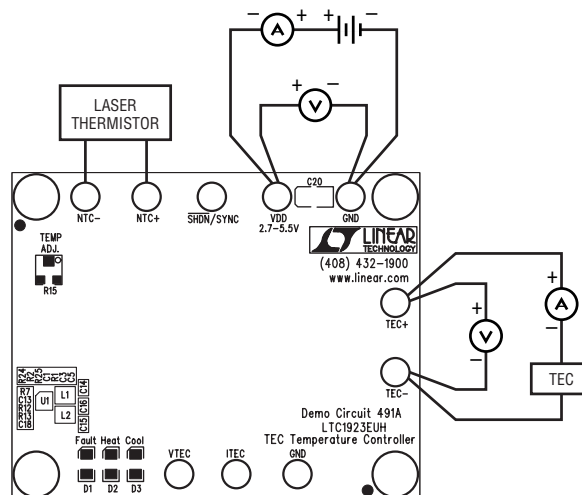
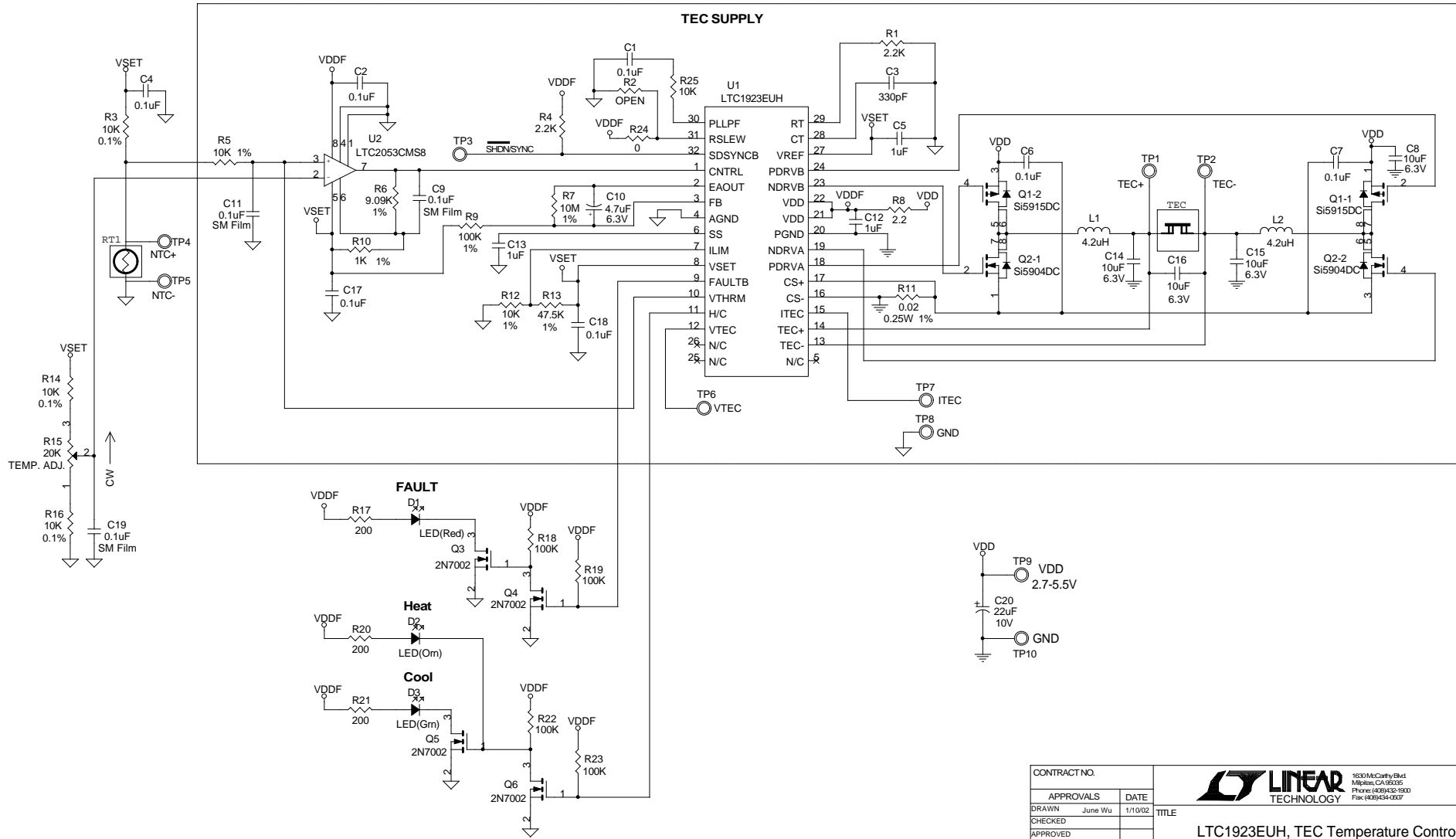



Figure 1. Proper Measurement Equipment Setup



CONTRACT NO.		 1600 McCarthy Blvd Milpitas, CA 95035 Phone: (408)432-1900 Fax: (408)434-0067	
APPROVALS	DATE	TITLE	
DRAWN	June Wu	LTC1923EUH, TEC Temperature Controller	
CHECKED	1/10/02	SIZE	CAGE CODE
APPROVED		DWGNO	REV
ENGINEER	Wei Chen	DC491A	A
DESIGNER		SCALE:	FILENAME:
Friday, April 05, 2002		SHEET	1 OF 1

Item	Qty	Reference	Part Description	Manufacture / Part #
1	7	C1,C2,C4,C6,C7,C17,C18	CAP., X5R, 0.1uF, 10V, 20% 0402	TAIYO YUDEN, LMK105BJ104MV
2	1	C3	CAP., X7R, 330pF, 50V, 20% 0402	AVX, 04025C331MAT
3	3	C5,C12,C13	CAP., X5R, 1uF, 6.3V, 20% 0603	TAIYO YUDEN, JMK107BJ105MA
4	4	C8,C14,C15,C16	CAP., X5R, 10uF, 6.3V, 20% 1206	TAIYO YUDEN, JMK316BJ106ML
5	3	C9,C11,C19	CAP., SM Film, 0.1uF, 16V, 20% 0805	Panasonic, ECP-U1C104MA5
6	1	C10	CAP., Tant., 15uF, 10V, 20% 3216	AVX, TAJA156M010R
7	1	C20	CAP., Tant., 22uF, 10V, 20% 3528	AVX, TPSB226M010R
8	1	D1	LED(Red)	Panasonic, LN1251-C-TR
9	1	D2	LED(Orn)	Panasonic, LN1851-C-TR
10	1	D3	LED(Grn)	Panasonic, LN1351-C-TR
11	2	L1,L2	INDUCTOR, 4.2uH CDRH5D28	SUMIDA, CDRH5D28-4R2
12	1	Q1	Dual P-MOSFET, Si5915DC 1206-8	VISHAY, SI5915DC
13	1	Q2	Dual N-MOSFET, Si5904DC 1206-8	VISHAY, SI5904DC
14	4	Q3,Q4,Q5,Q6	N-MOSFET, 2N7002	Diodes Inc., 2N7002-7
15	2	R1,R4	RES., CHIP, 2.2K, 1/16W, 5% 0402	AAC, CR05-222JM
16	1	R25	RES., CHIP, 10K, 1/16W, 5% 0402	AAC, CR05-103JM
17	0	R2(not install)	RES., 0402	
18	3	R3,R14,R16	RES., CHIP, 10K, 0.1W, 0.1% 0805	KOA, RN73T2A1002B
19	2	R5,R12	RES., CHIP, 10K, 1/16W, 1% 0402	AAC, CR05-1002FM
20	1	R6	RES., CHIP, 9.09K, 1/16W, 1% 0402	AAC, CR05-9091FM
21	1	R7	RES., CHIP, 10M, 1/16W, 1% 0402	AAC, CR05-1005FM
22	1	R8	RES., CHIP, 2.2, 1/16W, 5% 0402	AAC, CR05-2R2JM
23	5	R9,R18,R19,R22,R23	RES., CHIP, 100K, 1/16W, 1% 0402	AAC, CR05-1003FM
24	1	R10	RES., CHIP, 1K, 1/16W, 1% 0402	AAC, CR05-1001FM
25	1	R11	RES., CHIP, 0.02, 0.25W, 1% 1206	IRC, LRF1206-01-R020-F
26	1	R13	RES., CHIP, 47.5K, 1/16W, 1% 0402	AAC, CR05-4752FM
27	1	R15	Pot. 11 Turns 20K	Bourns, 3224W-1-203E
28	3	R17,R20,R21	RES., CHIP, 200, 1/16W, 5% 0402	AAC, CR05-201JM
29	1	R24	RES., CHIP, 0, 1/16W, 5% 0402	AAC, CR05-000JM
30	10	TP1-TP10	TURRET,	MILL-MAX, 2501-2
31	1	U1	I.C., LTC1923EUH, MLP-32	LINEAR., LTC1923EUH
32	1	U2	I.C., LTC2053, MS8	LINEAR., LTC2053CMS8
33	4		SCREW, #4-40, 1/4"	ANY
34	4		STANDOFF, NYLON HEX #4-40 1/4"	MICRO PLASTICS 14HTSP101
35	1		PRINTED CIRCUIT BOARD	DEMO CIRCUIT 491A