



STP100NF04 STB100NF04, STB100NF04-1

N-CHANNEL 40V - 0.0043Ω - 120A TO-220/D²PAK/I²PAK
STripFET™ II POWER MOSFET

AUTOMOTIVE SPECIFIC

TYPE	V _{DSS}	R _{DS(on)}	I _D	P _w
STP100NF04	40 V	< 0.0046 Ω	120 A	300 W
STB100NF04	40 V	< 0.0046 Ω	120 A	300 W
STB100NF04-1	40 V	< 0.0046 Ω	120 A	300 W

- TYPICAL R_{DS(on)} = 0.0043 Ω
- STANDARD THRESHOLD DRIVE
- 100% AVALANCHE TESTED

DESCRIPTION

This Power Mosfet is the latest development of ST-Microelectronics unique "Single Feature Size™" strip-based process. The resulting transistor shows extremely high packing density for low on-resistance, rugged avalanche characteristics and less critical alignment steps therefore a remarkable manufacturing reproducibility.

APPLICATIONS

- HIGH CURRENT, HIGH SWITCHING SPEED
- MOTOR CONTROL, AUDIO AMPLIFIERS
- DC-DC & DC-AC CONVERTERS
- SOLENOID AND RELAY DRIVERS

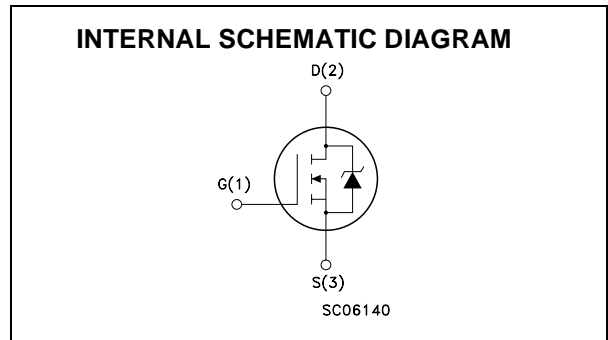
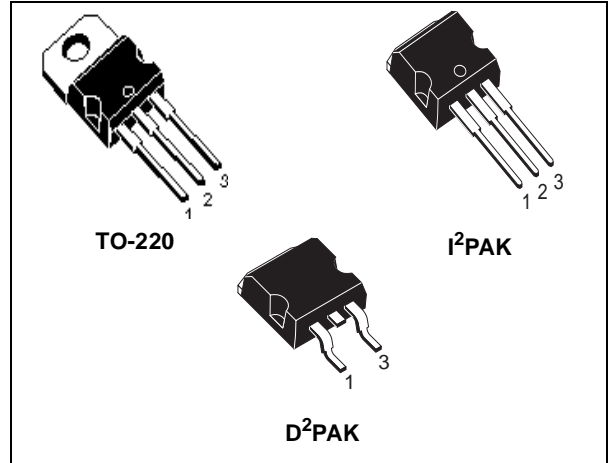

ORDERING INFORMATION

SALES TYPE	MARKING	PACKAGE	PACKAGING
STP100NF04	P100NF04	TO-220	TUBE
STB100NF04T4	B100NF04	D ² PAK	TAPE & REEL
STB100NF04-1	B100NF04	I ² PAK	TUBE

STP100NF04, STB100NF04, STB100NF04-1

ABSOLUTE MAXIMUM RATINGS

Symbol	Parameter	Value	Unit
V _{DS}	Drain-source Voltage (V _{GS} = 0)	40	V
V _{DGR}	Drain-gate Voltage (R _{GS} = 20 kΩ)	40	V
V _{GS}	Gate- source Voltage	± 20	V
I _D (#)	Drain Current (continuous) at T _C = 25°C	120	A
I _D	Drain Current (continuous) at T _C = 100°C	120	A
I _{DM} (•)	Drain Current (pulsed)	480	A
P _{TOT}	Total Dissipation at T _C = 25°C	300	W
	Derating Factor	2	W/°C
dv/dt (1)	Peak Diode Recovery voltage slope	6	V/ns
E _{AS} (2)	Single Pulse Avalanche Energy	1.2	J
T _j T _{stg}	Operating Junction Temperature Storage Temperature	-55 to 175	°C

(•) Pulse width limited by safe operating area

(1) I_{SD} ≤ 120A, di/dt ≤ 300A/μs, V_{DD} ≤ V_{(BR)DSS}, T_j ≤ T_{JMAX}.

(2) Starting T_j = 25°C, I_d = 60A, V_{DD} = 30 V

(#) Current Limited by Package

THERMAL DATA

		TO-220 / I ² PAK / D ² PAK	
R _{thj-case}	Thermal Resistance Junction-case Max	0.5	°C/W
R _{thj-pcb}	Thermal Resistance Junction-pcb Max	See Curve on page 6	°C/W
R _{thj-amb}	Thermal Resistance Junction-ambient (Free air) Max	62.5	°C/W
T _I	Maximum Lead Temperature For Soldering Purpose	300	°C

ELECTRICAL CHARACTERISTICS (TCASE = 25°C UNLESS OTHERWISE SPECIFIED)

ON/OFF

Symbol	Parameter	Test Conditions	Min.	Typ.	Max.	Unit
V _{(BR)DSS}	Drain-source Breakdown Voltage	I _D = 250 μA, V _{GS} = 0	40			V
I _{DSS}	Zero Gate Voltage Drain Current (V _{GS} = 0)	V _{DS} = Max Rating V _{DS} = Max Rating, T _C = 125 °C			1 10	μA μA
I _{GSS}	Gate-body Leakage Current (V _{DS} = 0)	V _{GS} = ± 20V			±100	nA
V _{GS(th)}	Gate Threshold Voltage	V _{DS} = V _{GS} , I _D = 250μA	2		4	V
R _{DS(on)}	Static Drain-source On Resistance	V _{GS} = 10V, I _D = 50 A		0.0043	0.0046	Ω

ELECTRICAL CHARACTERISTICS (CONTINUED)

DYNAMIC

Symbol	Parameter	Test Conditions	Min.	Typ.	Max.	Unit
g_{fs} (1)	Forward Transconductance	$V_{DS} = 15\text{ V}$, $I_D = 50\text{ A}$		150		S
C_{iss} C_{oss} C_{rss}	Input Capacitance Output Capacitance Reverse Transfer Capacitance	$V_{DS} = 25\text{ V}$, $f = 1\text{ MHz}$, $V_{GS} = 0$		5100 1300 160		pF pF pF

SWITCHING ON

Symbol	Parameter	Test Conditions	Min.	Typ.	Max.	Unit
$t_{d(on)}$ t_r	Turn-on Delay Time Rise Time	$V_{DD} = 20\text{ V}$, $I_D = 60\text{ A}$ $R_G = 4.7\Omega$ $V_{GS} = 10\text{ V}$ (Resistive Load see, Figure 3)		35 220		ns ns
Q_g Q_{gs} Q_{gd}	Total Gate Charge Gate-Source Charge Gate-Drain Charge	$V_{DD} = 32\text{ V}$, $I_D = 120\text{ A}$, $V_{GS} = 10\text{ V}$ (see, Figure 4)		110 35 35	150	nC nC nC

SWITCHING OFF

Symbol	Parameter	Test Conditions	Min.	Typ.	Max.	Unit
$t_{d(off)}$ t_f	Turn-off Delay Time Fall Time	$V_{DD} = 20\text{ V}$, $I_D = 60\text{ A}$ $R_G = 4.7\Omega$ $V_{GS} = 10\text{ V}$ (Resistive Load see, Figure 3)		80 50		ns ns

SOURCE DRAIN DIODE

Symbol	Parameter	Test Conditions	Min.	Typ.	Max.	Unit
I_{SD} I_{SDM} (2)	Source-drain Current Source-drain Current (pulsed)				120 480	A A
V_{SD} (1)	Forward On Voltage	$I_{SD} = 120\text{ A}$, $V_{GS} = 0$			1.3	V
t_{rr} Q_{rr} I_{RRM}	Reverse Recovery Time Reverse Recovery Charge Reverse Recovery Current	$I_{SD} = 120\text{ A}$, $di/dt = 100\text{ A}/\mu\text{s}$ $V_{DD} = 20\text{ V}$, $T_j = 150^\circ\text{C}$ (see test circuit, Figure 5)		75 185 5		ns nC A

Note: 1. Pulsed: Pulse duration = 300 μs , duty cycle 1.5 %.
2. Pulse width limited by safe operating area.

Power Derating vs Tc

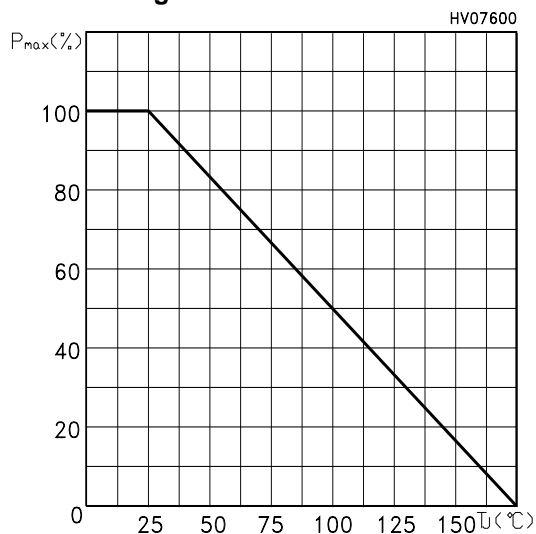

Max Id Current vs Tc

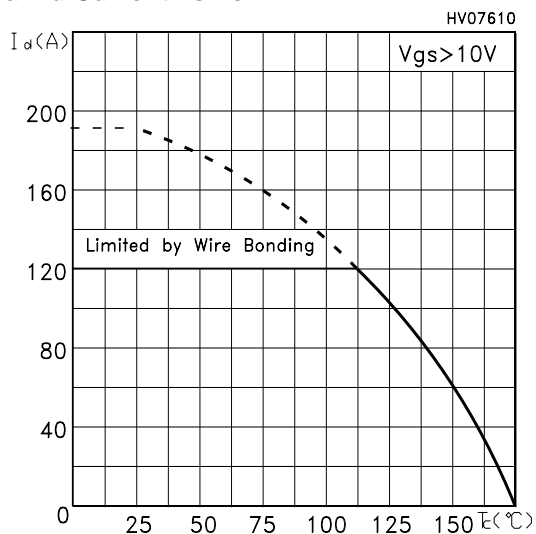

Output Characteristics

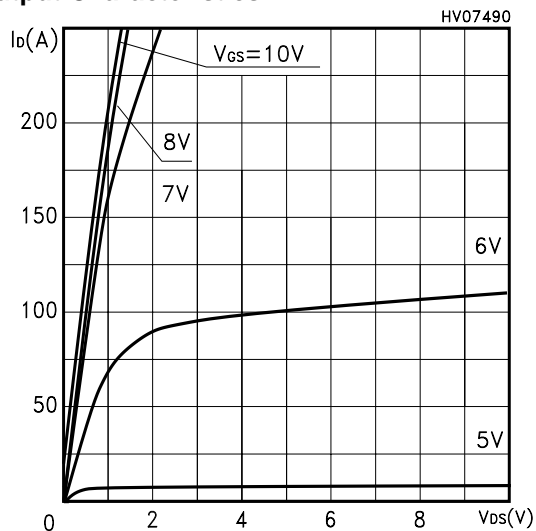

Transfer Characteristics

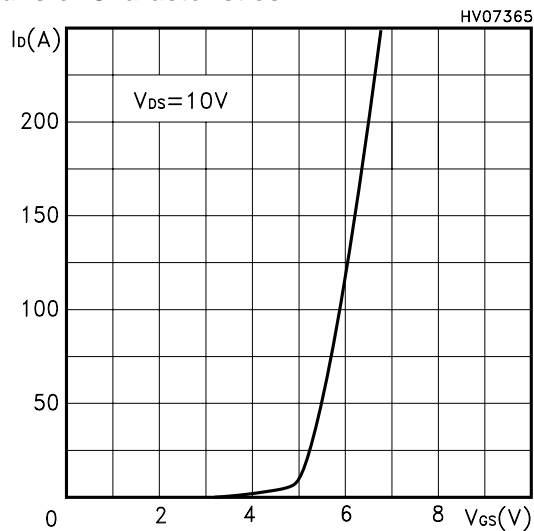

Transconductance

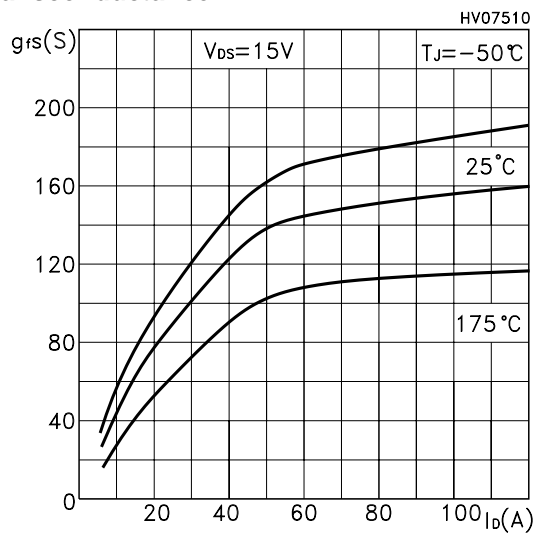

Static Drain-source On Resistance

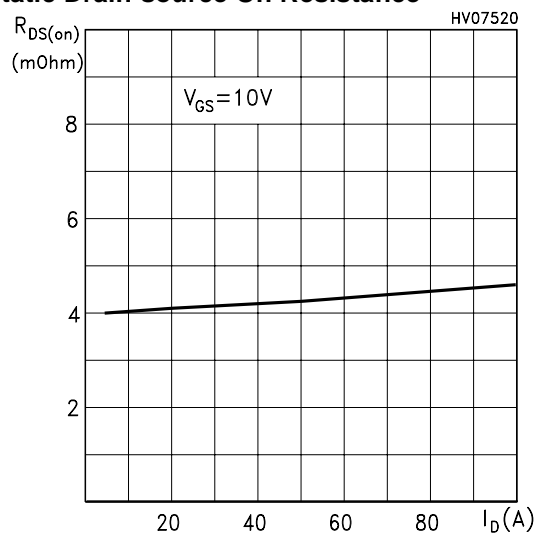

Gate Charge vs Gate-source Voltage

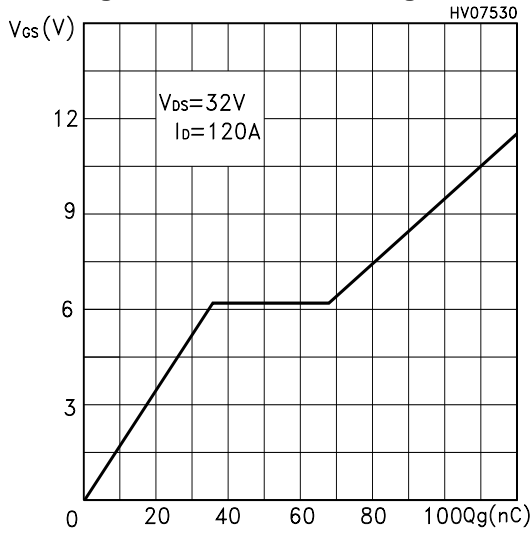

Capacitance Variations

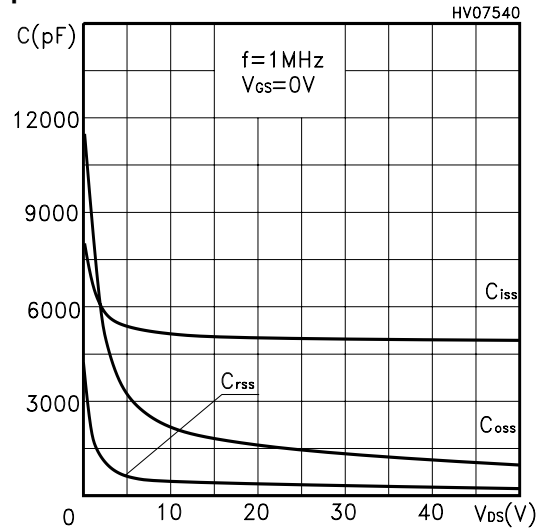

Normalized Gate Threshold Voltage vs Temp.

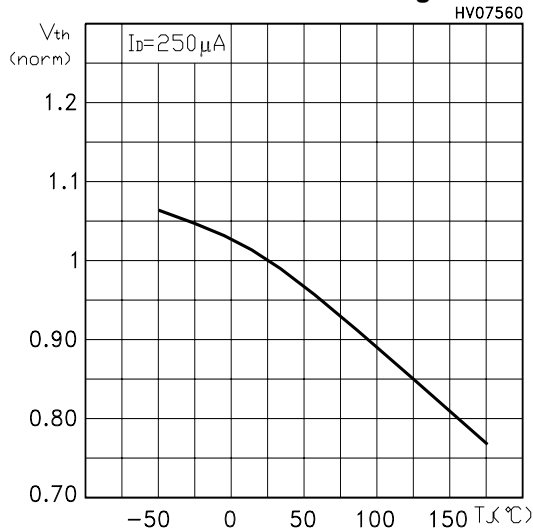

Normalized On Resistance vs Temperature

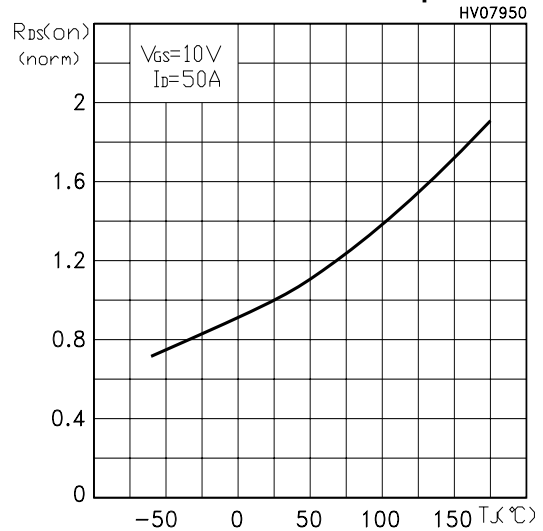

Source-drain Diode Forward Characteristics

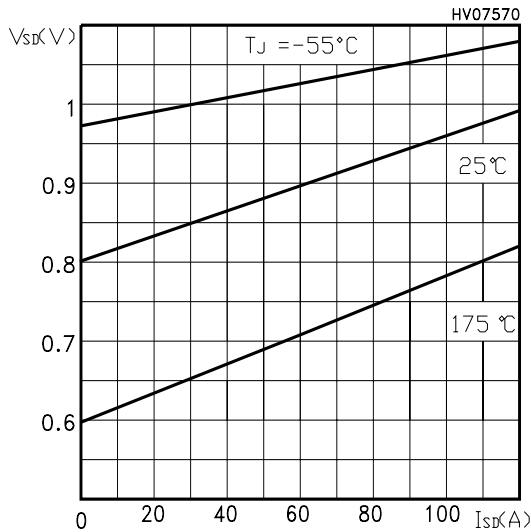

Normalized Breakdown voltage vs Temperature

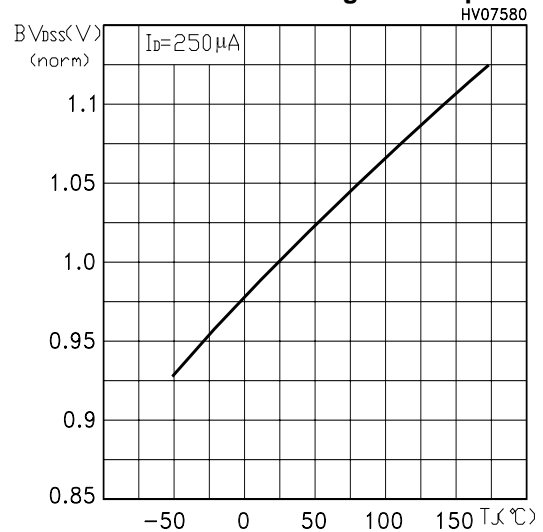

STP100NF04, STB100NF04, STB100NF04-1

Thermal Resistance R_{thj-a} vs PCB Copper Area

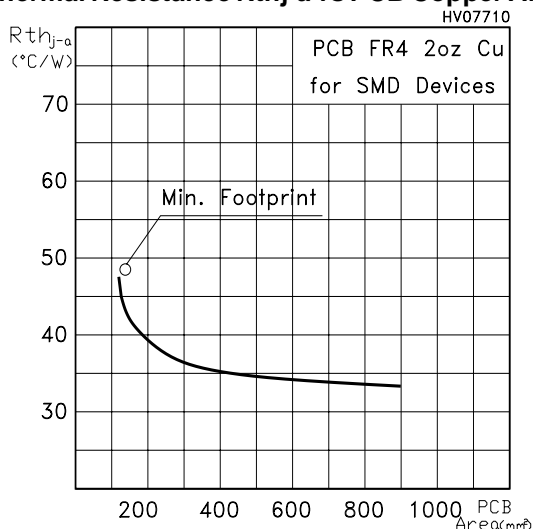

Max Power Dissipation vs PCB Copper Area

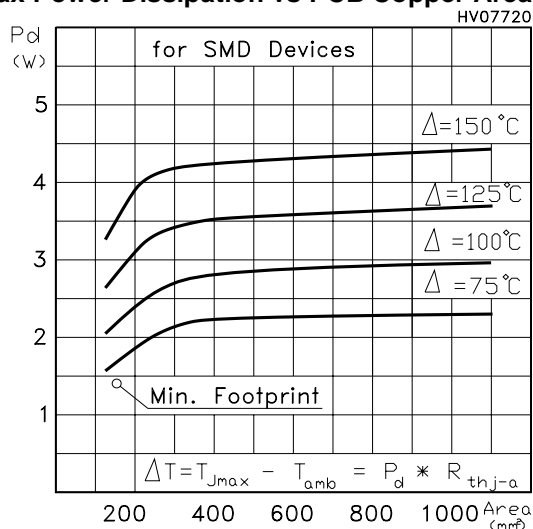

Safe Operating Area

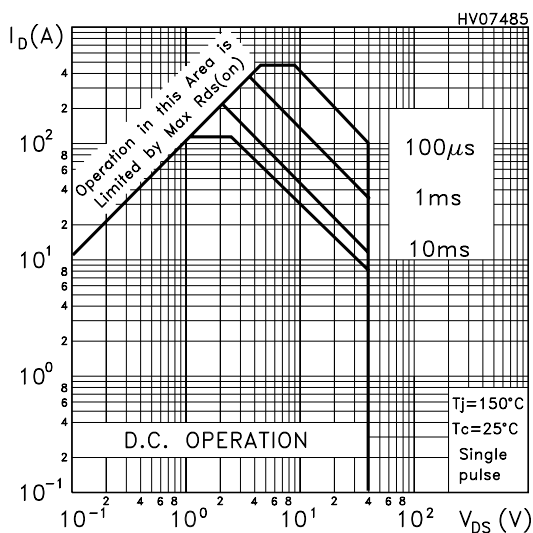

Thermal Impedance

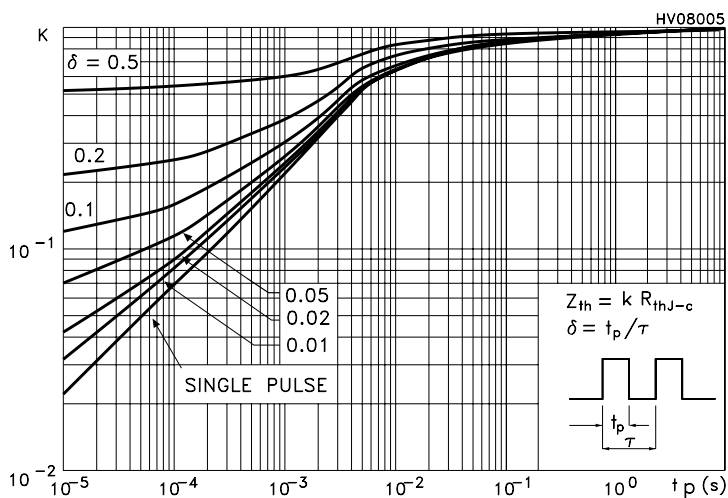

Allowable I_{AV} vs. Time in Avalanche

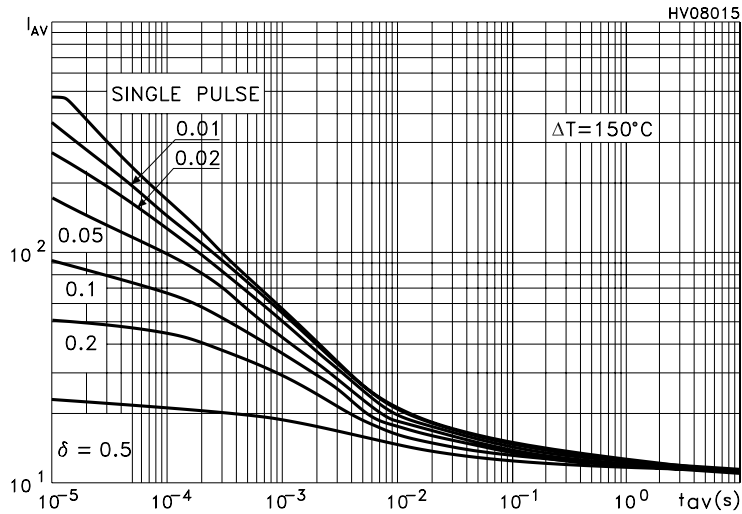

The previous curve gives the safe operating area for unclamped inductive loads, single pulse or repetitive, under the following conditions:

$$P_{D(AVE)} = 0.5 * (1.3 * BV_{DSS} * I_{AV})$$

$$E_{AS(AR)} = P_{D(AVE)} * t_{AV}$$

Where:

I_{AV} is the Allowable Current in Avalanche

$P_{D(AVE)}$ is the Average Power Dissipation in Avalanche (Single Pulse)

t_{AV} is the Time in Avalanche

To derate above 25 °C, at fixed I_{AV} , the following equation must be applied:

$$I_{AV} = 2 * (T_{jmax} - T_{CASE}) / (1.3 * BV_{DSS} * Z_{th})$$

Where:

$Z_{th} = K * R_{th}$ is the value coming from Normalized Thermal Response at fixed pulse width equal to T_{AV} .

SPICE THERMAL MODEL

Parameter	Node	Value
CTHERM1	5 - 4	0.011
CTHERM2	4 - 3	0.0012
CTHERM3	3 - 2	0.05
CTHERM4	2 - 1	0.1
R THERM1	5 - 4	0.09
R THERM2	4 - 3	0.02
R THERM3	3 - 2	0.11
R THERM4	2 - 1	0.17

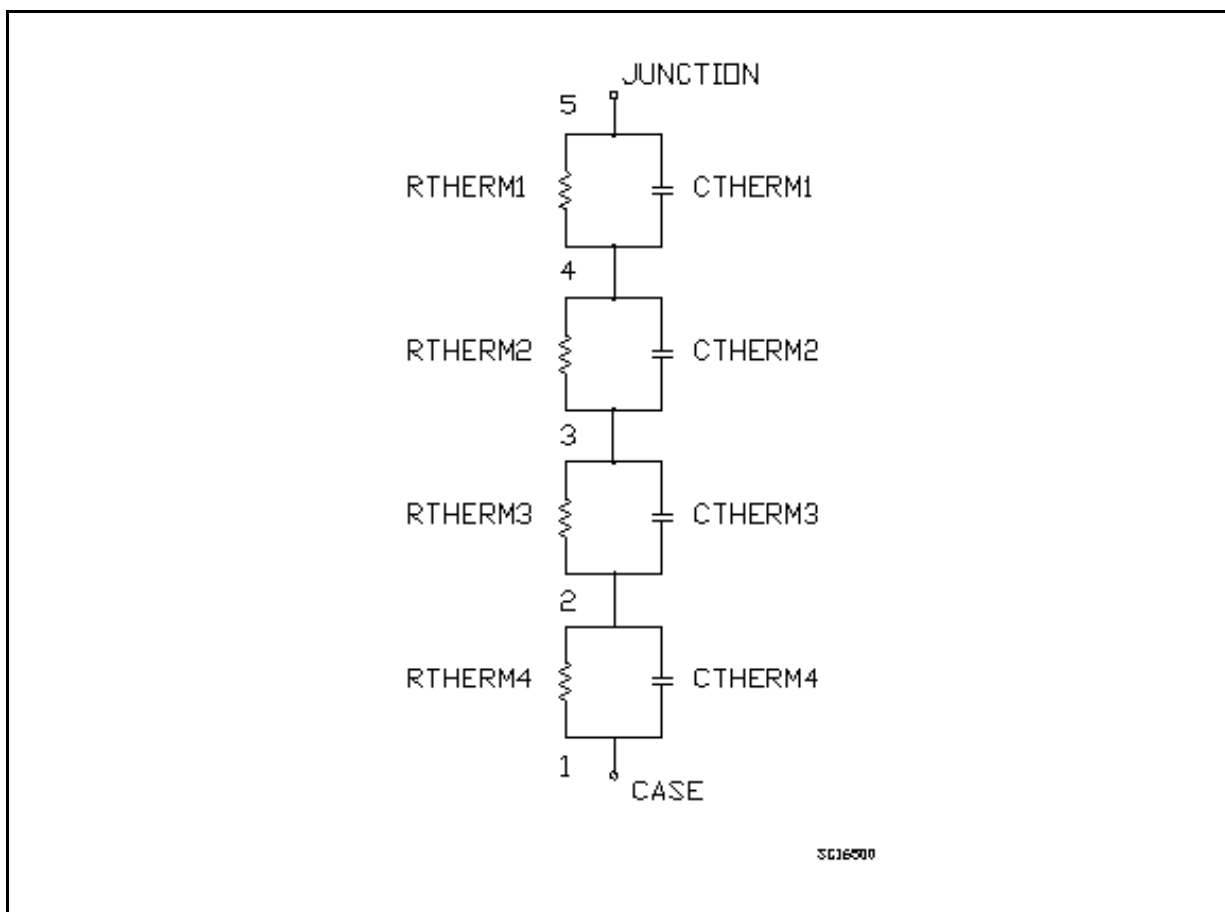

Fig. 1: Unclamped Inductive Load Test Circuit

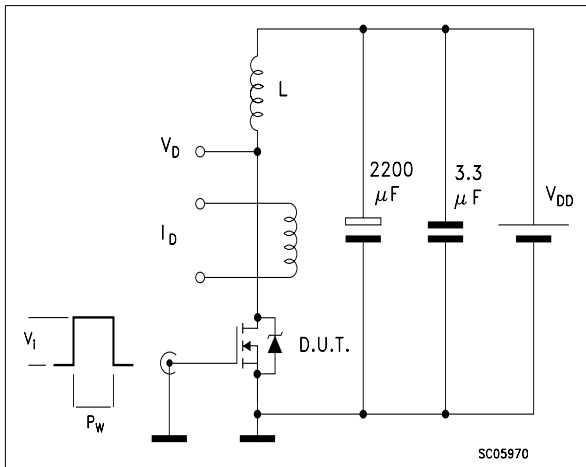

Fig. 2: Unclamped Inductive Waveform

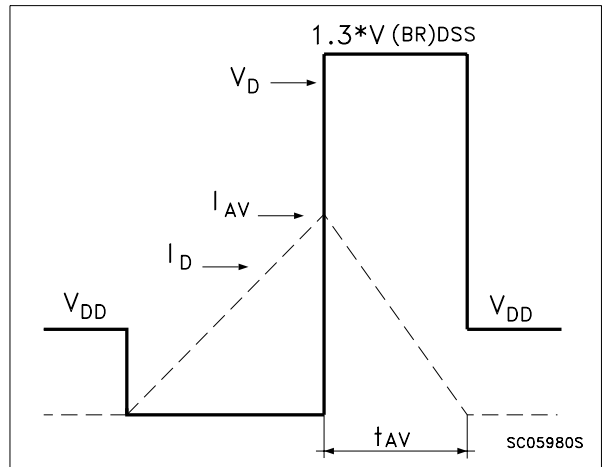

Fig. 3: Switching Times Test Circuit For Resistive Load

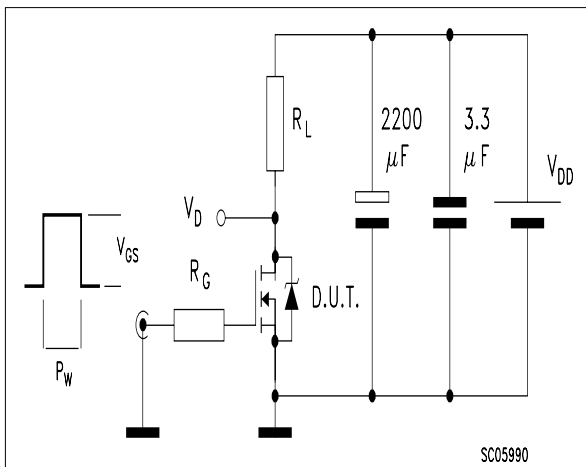

Fig. 3.1: Inductive Load Switching And Diode Recovery Times Waveform

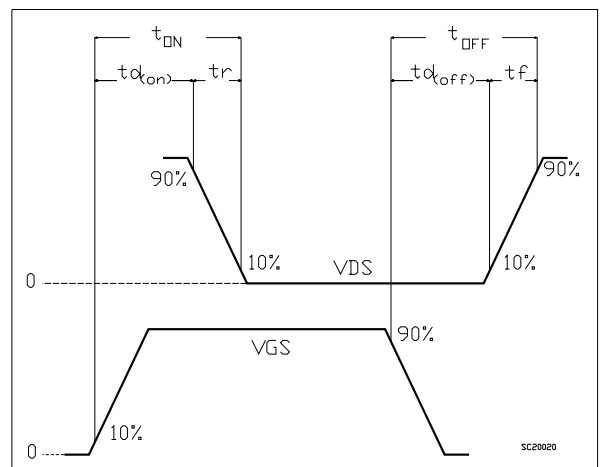

Fig. 4: Gate Charge test Circuit

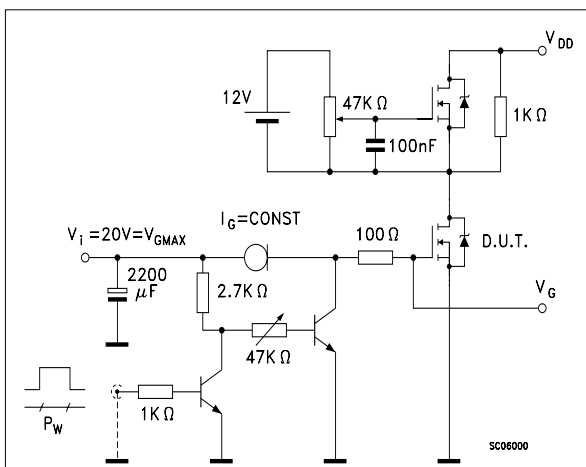

Fig. 4.1: Gate Charge test Waveform

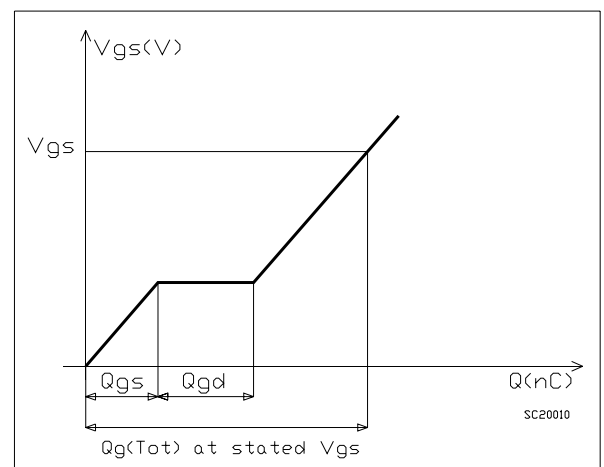

Fig. 5: Test Circuit For Diode Recovery Times

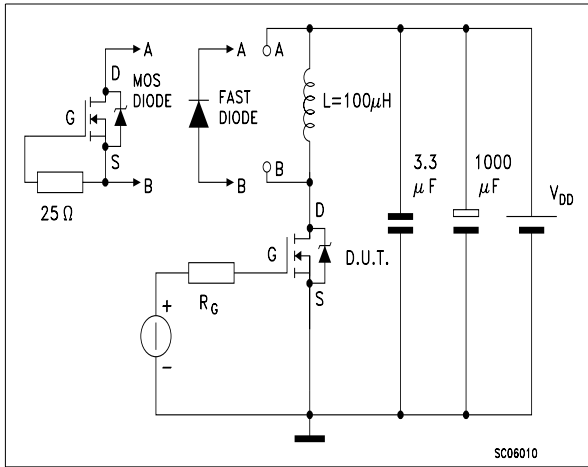
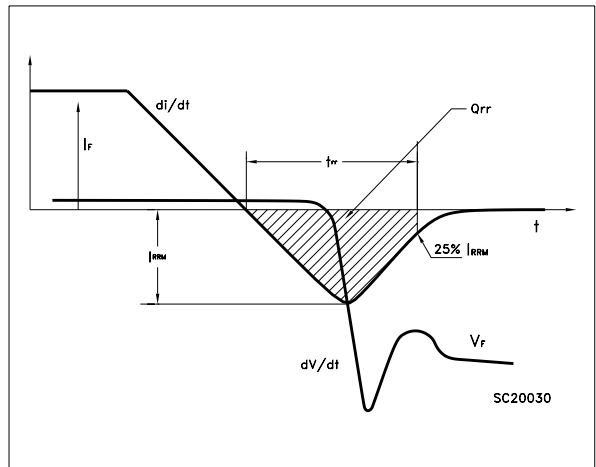
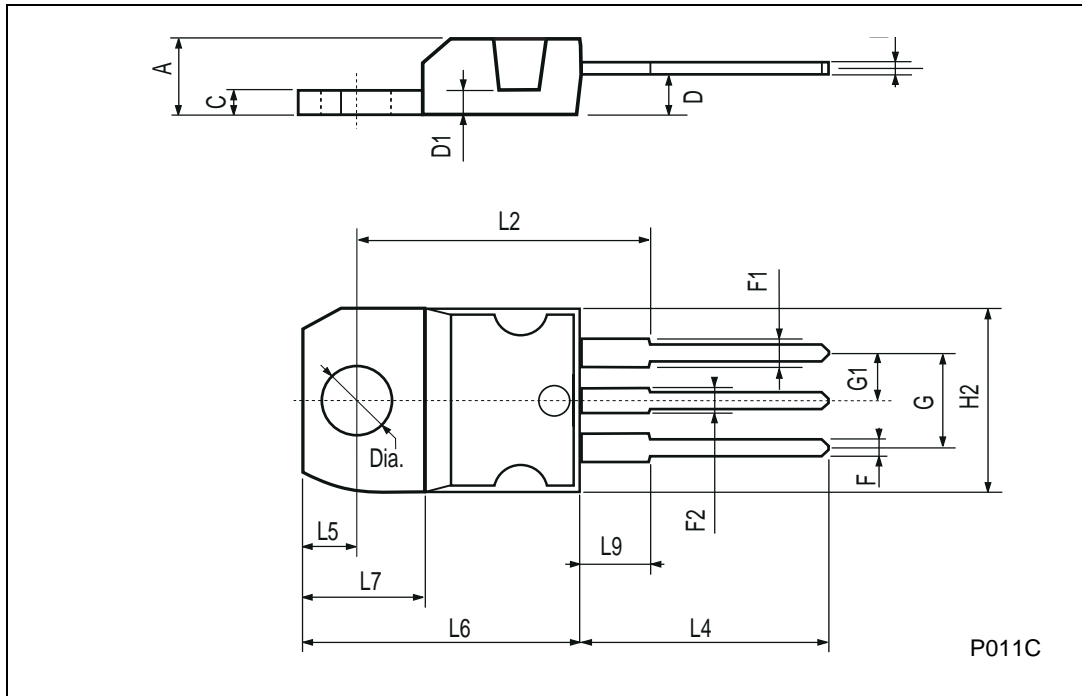

Fig. 5.1: Diode Recovery Times Waveform



TO-220 MECHANICAL DATA

DIM.	mm			inch		
	MIN.	TYP.	MAX.	MIN.	TYP.	MAX.
A	4.40		4.60	0.173		0.181
C	1.23		1.32	0.048		0.051
D	2.40		2.72	0.094		0.107
D1		1.27			0.050	
E	0.49		0.70	0.019		0.027
F	0.61		0.88	0.024		0.034
F1	1.14		1.70	0.044		0.067
F2	1.14		1.70	0.044		0.067
G	4.95		5.15	0.194		0.203
G1	2.4		2.7	0.094		0.106
H2	10.0		10.40	0.393		0.409
L2		16.4			0.645	
L4	13.0		14.0	0.511		0.551
L5	2.65		2.95	0.104		0.116
L6	15.25		15.75	0.600		0.620
L7	6.2		6.6	0.244		0.260
L9	3.5		3.93	0.137		0.154
DIA.	3.75		3.85	0.147		0.151



D²PAK MECHANICAL DATA

DIM.	mm.			inch		
	MIN.	TYP	MAX.	MIN.	TYP.	MAX.
A	4.4		4.6	0.173		0.181
A1	2.49		2.69	0.098		0.106
A2	0.03		0.23	0.001		0.009
B	0.7		0.93	0.027		0.036
B2	1.14		1.7	0.044		0.067
C	0.45		0.6	0.017		0.023
C2	1.23		1.36	0.048		0.053
D	8.95		9.35	0.352		0.368
D1		8			0.315	
E	10		10.4	0.393		
E1		8.5			0.334	
G	4.88		5.28	0.192		0.208
L	15		15.85	0.590		0.625
L2	1.27		1.4	0.050		0.055
L3	1.4		1.75	0.055		0.068
M	2.4		3.2	0.094		0.126
R		0.4			0.015	
V2	0°		8°			

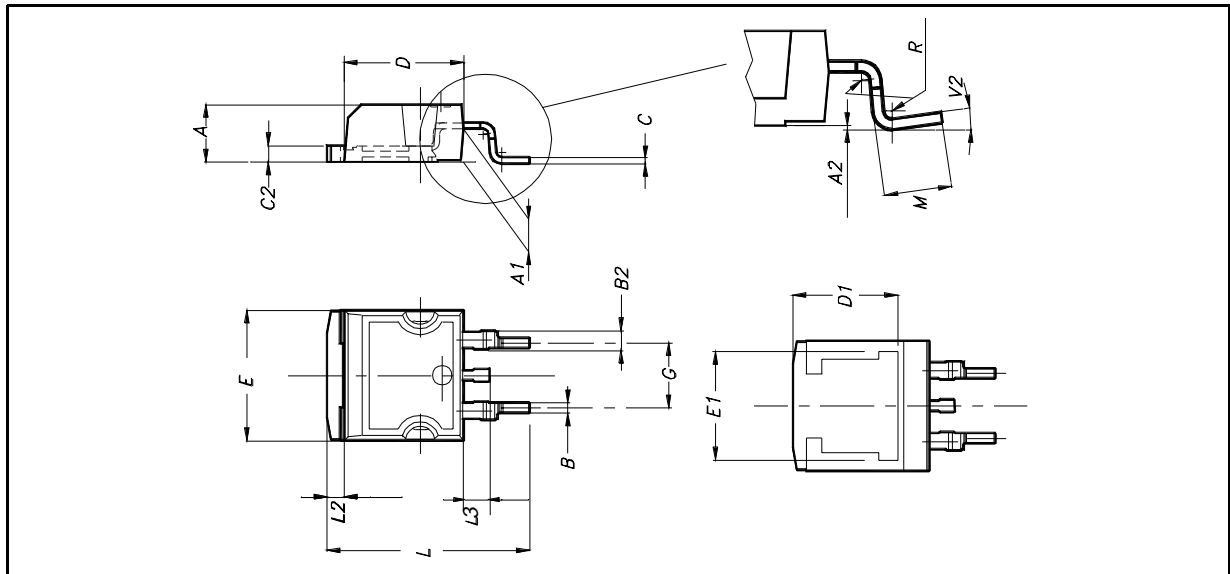

TO-262 (I²PAK) MECHANICAL DATA

DIM.	mm			inch		
	MIN.	TYP.	MAX.	MIN.	TYP.	MAX.
A	4.4		4.6	0.173		0.181
A1	2.49		2.69	0.098		0.106
B	0.7		0.93	0.027		0.036
B2	1.14		1.7	0.044		0.067
C	0.45		0.6	0.017		0.023
C2	1.23		1.36	0.048		0.053
D	8.95		9.35	0.352		0.368
e	2.4		2.7	0.094		0.106
E	10		10.4	0.393		0.409
L	13.1		13.6	0.515		0.531
L1	3.48		3.78	0.137		0.149
L2	1.27		1.4	0.050		0.055

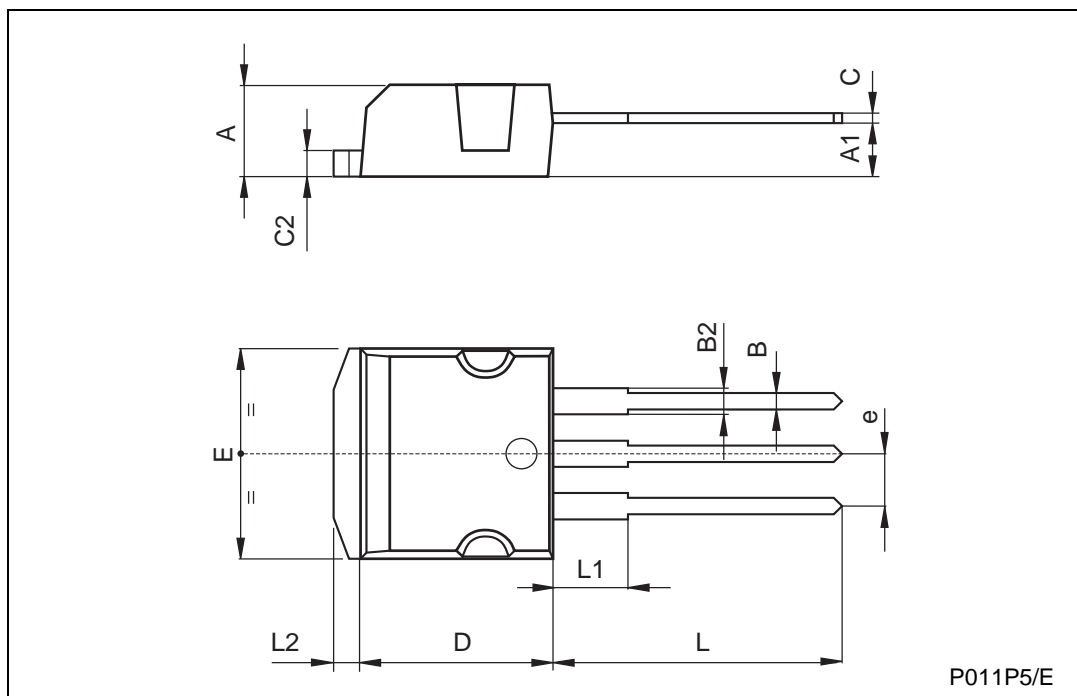

D²PAK FOOTPRINT

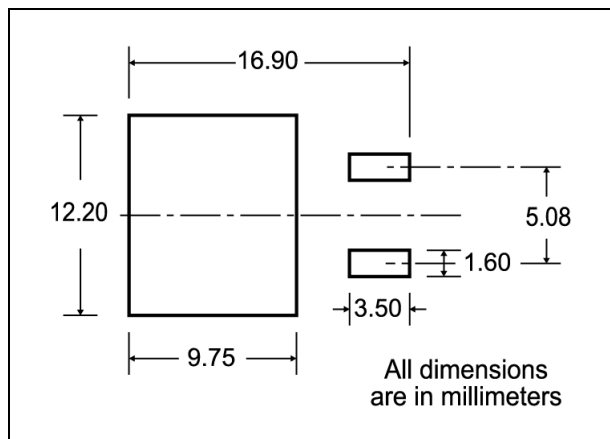

TUBE SHIPMENT (no suffix)*

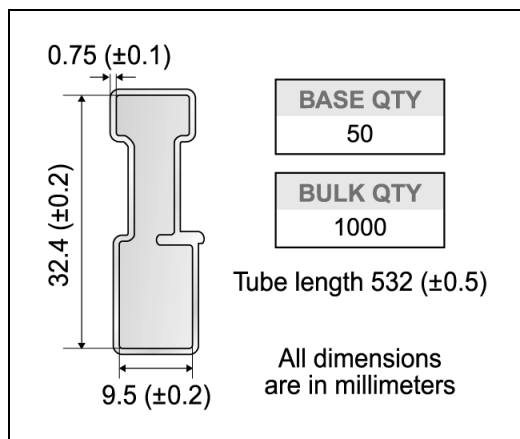

TAPE AND REEL SHIPMENT (suffix "T4")*

Diagram showing the tape mechanical data. The tape has a width of 25 mm. The distance from the center of the tape to the center of the access hole is 40 mm min. The distance from the center of the tape to the center of the slot is B. The distance from the center of the tape to the center of the hub is N. The distance from the center of the tape to the center of the cavity is G. The distance from the center of the tape to the center of the top cover tape is K₀. The distance from the center of the tape to the center of the bottom cover tape is D₁. The distance from the center of the tape to the center of the cavity is A₀. The distance from the center of the tape to the center of the cavity is P₁. The distance from the center of the tape to the center of the cavity is P₂. The distance from the center of the tape to the center of the cavity is P₀. The distance from the center of the tape to the center of the cavity is E. The distance from the center of the tape to the center of the cavity is F. The distance from the center of the tape to the center of the cavity is W. The distance from the center of the tape to the center of the cavity is R min. The distance from the center of the tape to the center of the cavity is TRL. The distance from the center of the tape to the center of the cavity is FEED DIRECTION. The distance from the center of the tape to the center of the cavity is Bending radius.

REEL MECHANICAL DATA

DIM.	mm		inch	
	MIN.	MAX.	MIN.	MAX.
A		330		12.992
B	1.5		0.059	
C	12.8	13.2	0.504	0.520
D	20.2		0.795	
G	24.4	26.4	0.960	1.039
N	100		3.937	
T		30.4		1.197

BASE QTY	BULK QTY
1000	1000

TAPE MECHANICAL DATA

DIM.	mm		inch	
	MIN.	MAX.	MIN.	MAX.
A0	10.5	10.7	0.413	0.421
B0	15.7	15.9	0.618	0.626
D	1.5	1.6	0.059	0.063
D1	1.59	1.61	0.062	0.063
E	1.65	1.85	0.065	0.073
F	11.4	11.6	0.449	0.456
K0	4.8	5.0	0.189	0.197
P0	3.9	4.1	0.153	0.161
P1	11.9	12.1	0.468	0.476
P2	1.9	2.1	0.075	0.082
R	50		1.574	
T	0.25	0.35	0.0098	0.0137
W	23.7	24.3	0.933	0.956

* on sales type
14/15

Information furnished is believed to be accurate and reliable. However, STMicroelectronics assumes no responsibility for the consequences of use of such information nor for any infringement of patents or other rights of third parties which may result from its use. No license is granted by implication or otherwise under any patent or patent rights of STMicroelectronics. Specification mentioned in this publication are subject to change without notice. This publication supersedes and replaces all information previously supplied. STMicroelectronics products are not authorized for use as critical components in life support devices or systems without express written approval of STMicroelectronics.

The ST logo is a trademark of STMicroelectronics

© 2000 STMicroelectronics – Printed in Italy – All Rights Reserved

STMicroelectronics GROUP OF COMPANIES

Australia - Brazil - China - Finland - France - Germany - Hong Kong - India - Italy - Japan - Malaysia - Malta - Morocco -
Singapore - Spain - Sweden - Switzerland - United Kingdom - U.S.A.

<http://www.st.com>