

97 series solder type how to order

Example of part number for solder type connectors is given below.

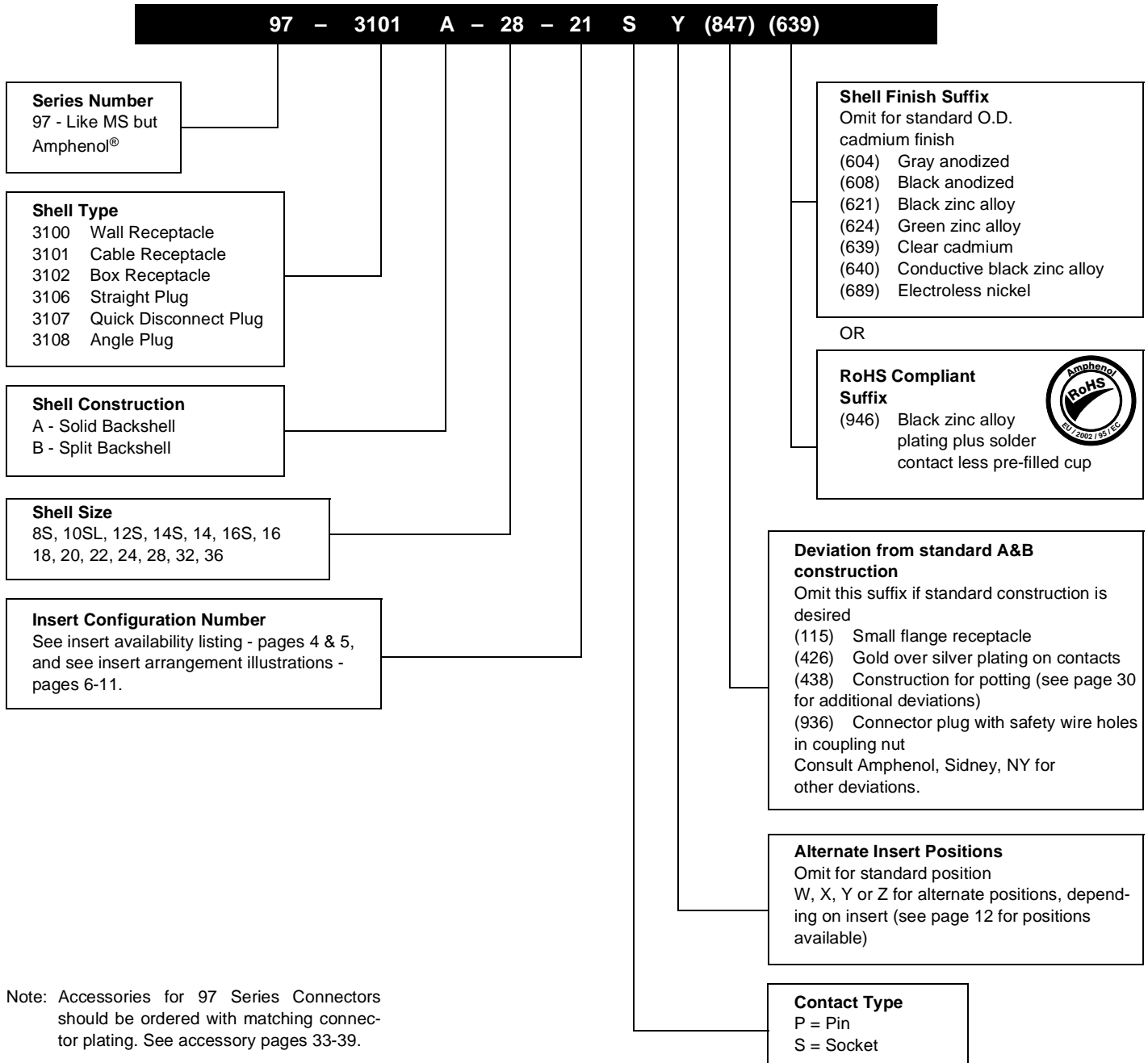

Note: Accessories for 97 Series Connectors should be ordered with matching connector plating. See accessory pages 33-39.

8/29/89 16:21 * 89241 16:30 * PRELSE * 10-820040/059 E001

4

3

2

1

REVISIONS				
ZONE	LTR	DESCRIPTION	DATE	APPROVED
—	E	(CLII) ADDED NOTE 7 ECN:22391	08/29/89 BURNSIDE	<i>M.C.</i> <i>J.B.</i>
	F	(CLII) SEE CHANGE NOTICE ECN:28598	5-4-94 DEMATTED	<i>ged</i>
	G	(CLII) SEE ECN:82021	8/6/96 Gill	<i>ged</i>
	H	(CLII) CHANGE BLOCK CHANGE ONLY WAS SHELL 10-617703-XX3(NOS LOT) ECN:89330	7/19/09 A.B. MAYHEW	<i>ged</i>

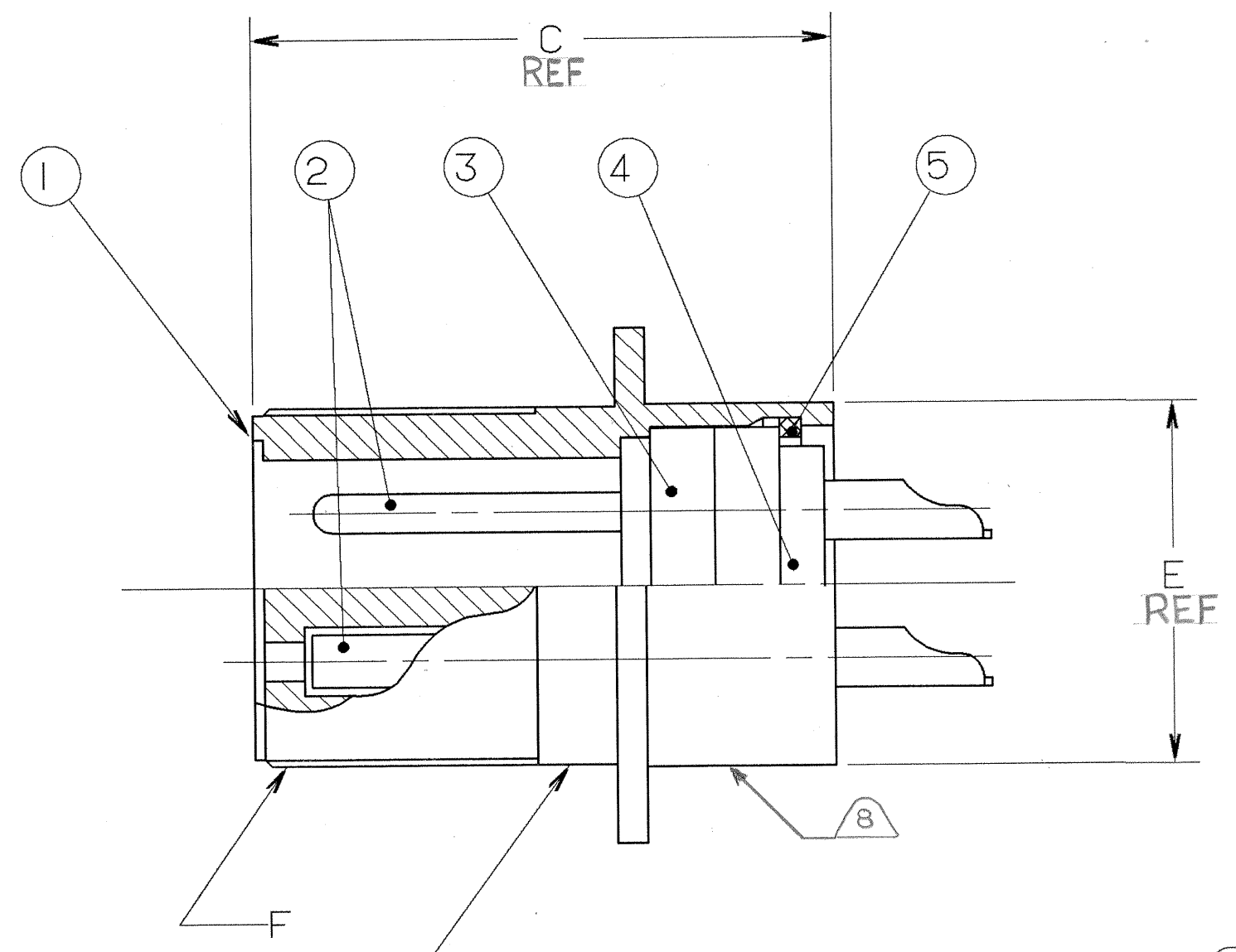
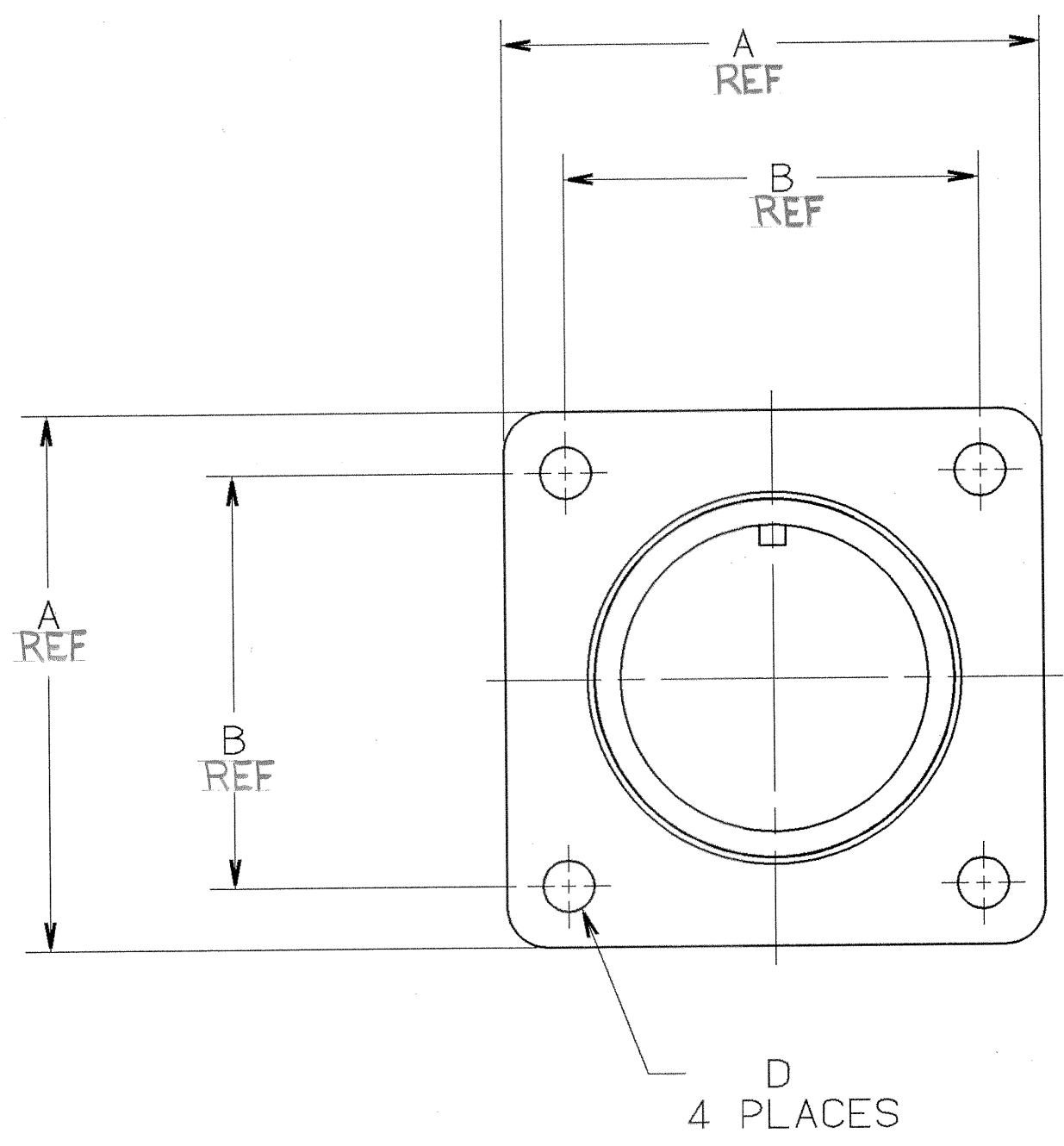

STAMP MS OR AMPHENOL ASSEMBLY NUMBER ON THIS SURFACE. CHARACTER HEIGHT .062 MINIMUM.

SEE SHEET 2.
NOTES:

THE USE OF THIS DOCUMENT IS UNLIMITED. HOWEVER, DOCUMENTS REFERENCED HEREON MAY CONTAIN LIMITED RIGHTS DATA.

N/A
N/A
NEXT ASSEMBLY

UNLESS OTHERWISE SPECIFIED LINEAR DIMENSIONS ARE IN INCHES.
TOLERANCES: .XXX±.010,
.XX ±.03, .X ±.1,
ANGLES ±2°.
OTHER STANDARDS PER 9-3800 AND DOD-D-1000.
NOTE REF. = **XX**

5	SEE NOTE	SEE NOTE 1	RING, RETAINING
4			INSERT, REAR
3			INSERT, FRONT
2			CONTACTS
1			SHELL

FIND NO.	QTY REQD.	FSCM NO.	PART NUMBER	DESCRIPTION	NOTE REF.
PARTS LIST					
SPECIFICATIONS		SIGNATURES		DATES	
MATERIAL SPEC. N/A		A. PRESCOTT		11/6/87	
		R. PHILPOTT		11/8/87	
PROCESS SPEC. 9-2437-33		J. BERNHARDT		11/10/87	
		N. HAYNER		11/10/87	
		1ST PART NO. 10-820050-01P			
AMPHENOL CORPORATION BENDIX CONNECTOR OPERATIONS SIDNEY, N.Y.		CONNECTOR, ELECTRICAL RECEPTACLE TYPE 97-3102A, OLIVE DRAB CADMIUM PLATED			
SIZE	FSCM NO.	C 77820 10-820040/059		REV.	H
SCALE	WT.	NONE		REF	N/A
			SHEET	1 OF 2	

97-3102A

SCANNED

A

TAB.

6/29/89 16:21 * 89241 13:02 * PRELISE * 10-820040/059 E002

D

C

B

A

D

C

B

A

4		3			2			1	
BENDIX ASSEMBLY NUMBER	AMPHENOL ASSEMBLY NUMBER	MS ASSEMBLY NUMBER	A	B	C	D DIA.	E DIA.	F THREAD	
10-820040-()	97-3102A- 8S -()	MS3102A- 8S -()	.875	.594	.938	.120	.438	.5000-28 UNEF-2A	
10-820041-()	-10S -()	-10S -()	1.000	.719	.938		.500	.6250-24 UNEF-2A	
10-820042-()	-10SL-()	-10SL-()	1.000	.719	.938		.688	.6250-24 UNEF-2A	
10-820043-()	-12S -()	-12S -()	1.094	.812	.961		.688	.7500-20 UNEF-2A	
10-820044-()	-12SL-()	-12SL-()	1.094	.812	.875		.688	.7500-20 UNEF-2A	
10-820045-()	-12 -()	-12 -()	1.094	.812	1.322		.688	.7500-20 UNEF-2A	
10-820046-()	-14S -()	-14S -()	1.188	.906	.944		.750	.8750-20 UNEF-2A	
10-820047-()	-14 -()	-14 -()	1.188	.906	1.322		.750	.8750-20 UNEF-2A	
10-820048-()	-16S -()	-16S -()	1.281	.969	.944		.875	1.0000-20 UNEF-2A	
10-820049-()	-16 -()	-16 -()	1.281	.969	1.353		.875	1.0000-20 UNEF-2A	
10-820050-()	-18 -()	-18 -()	1.375	1.063	1.353		1.000	1.1250-18 UNEF-2A	
10-820051-()	-20 -()	-20 -()	1.500	1.156	1.353		1.125	1.2500-18 UNEF-2A	
10-820052-()	-22 -()	-22 -()	1.625	1.250	1.353		2.250	1.3750-18 UNEF-2A	
10-820053-()	-24 -()	-24 -()	1.750	1.375	1.353	.147	1.375	1.5000-18 UNEF-2A	
10-820054-()	-28 -()	-28 -()	2.000	1.563	1.353	.147	1.625	1.7500-18 UNEF-2A	
10-820055-()	-32 -()	-32 -()	2.250	1.750	1.447	.173	1.906	2.0000-18 UNEF-2A	
10-820056-()	-36 -()	-36 -()	2.500	1.938	1.447		2.125	2.2500-16 UN-2A	
10-820057-()	-40 -()	-40 -()	2.750	2.188	1.447		2.375	2.5000-16 UN-2A	
10-820058-()	-44 -()	-44 -()	NOT AVAILABLE						
10-820059-()	-48 -()	-48 -()	NOT AVAILABLE						

TO COMPLETE, ADD APPLICABLE INSERT ARRANGEMENT SUFFIX PER 9-2437-33. 6

8. ~~ALTERNATE STAMPING LOCATION WHEN SPACE DOES NOT PERMIT STAMPING ON INDICATED SURFACE.~~
7. IDENTIFY PACKAGE WITH APPLICABLE MS OR 97- PART NUMBER PER NOTE 6.
6. FOR BENDIX INSERT ARRANGEMENT SUFFIX -1 THROUGH -49, STAMP MS ASSEMBLY NUMBER. FOR BENDIX INSERT ARRANGEMENT SUFFIX -50 THROUGH -99, AND -AA THROUGH -BC, STAMP AMPHENOL ASSEMBLY NUMBER.
5. FOR CONTACT ARRANGEMENT, SEE MIL-STD-1651 AND L-22208-() THROUGH L-22248-().
4. PACKAGE PER PRODUCTION PROCESS SHEET.
3. UNITS MEET THE APPLICABLE REQUIREMENTS OF MIL-C-5015.
2. SEE WORK ORDER FOR PERMISSIBLE ADDITIONAL OR ALTERNATE STAMPING.
1. SEE SEPARATE PARTS LIST FOR COMPONENT PART NUMBERS AND QUANTITIES.

NOTES:

THE USE OF THIS DOCUMENT IS UNLIMITED. HOWEVER, DOCUMENTS REFERENCED HEREON MAY CONTAIN LIMITED RIGHTS DATA.

SIZE	FSCM NO.	REV.
C	77820	H
SCALE	WT.	REF
		SHEET 2

COMPUTER GENERATED DRAWING

IMAGED / Nov 04 2004 09:26 AM

TAB.

97-3102A B A SCANNED