

LOC		DIST		REVISIONS			
P	LTR	DESCRIPTION	DATE	DMN	APVD		
D		REVISED PER ECO-07-008991	4/23/07	SS	GS		
D1		REVISED PER ECO-09-020935	27AUG09	KK	AEG		

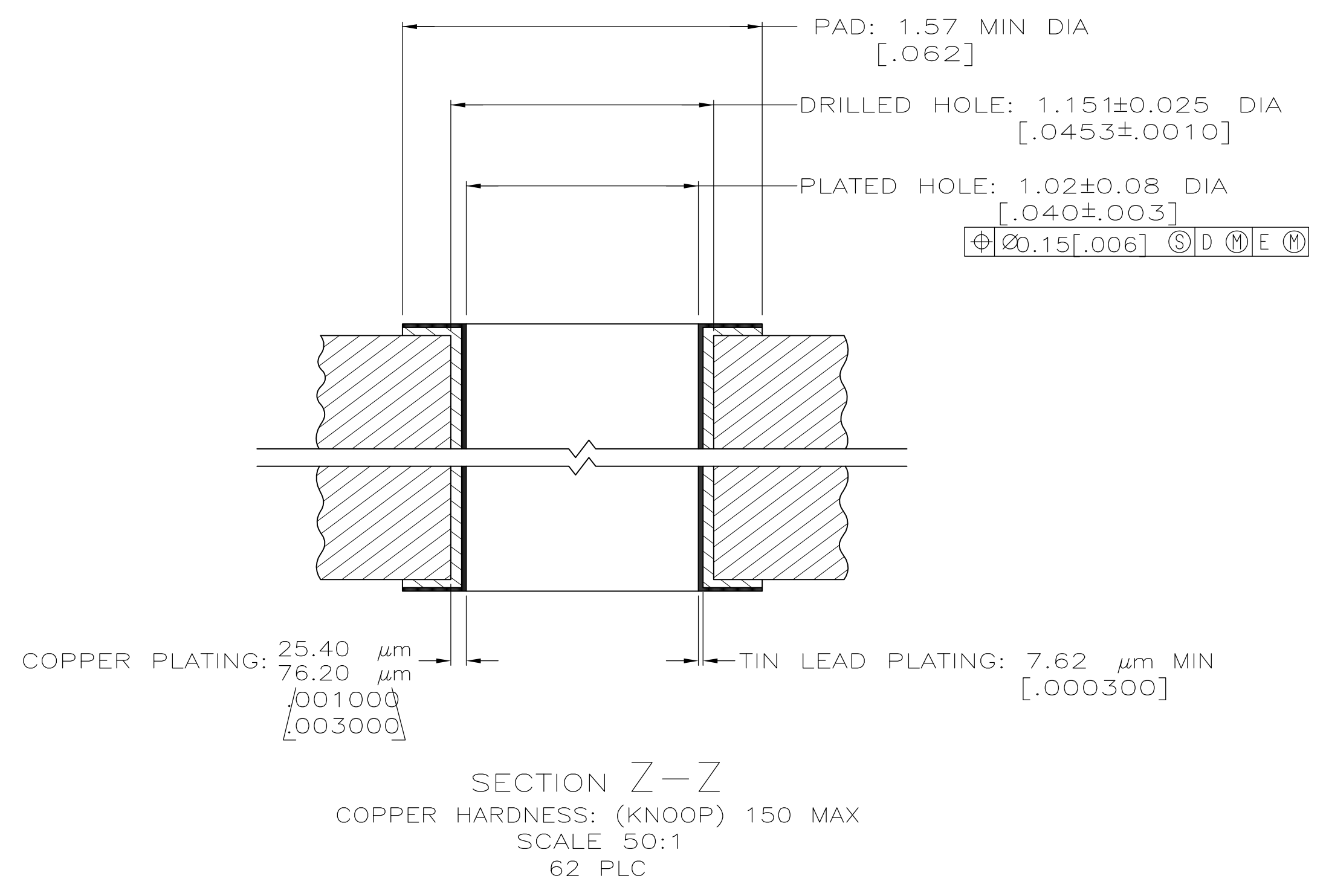
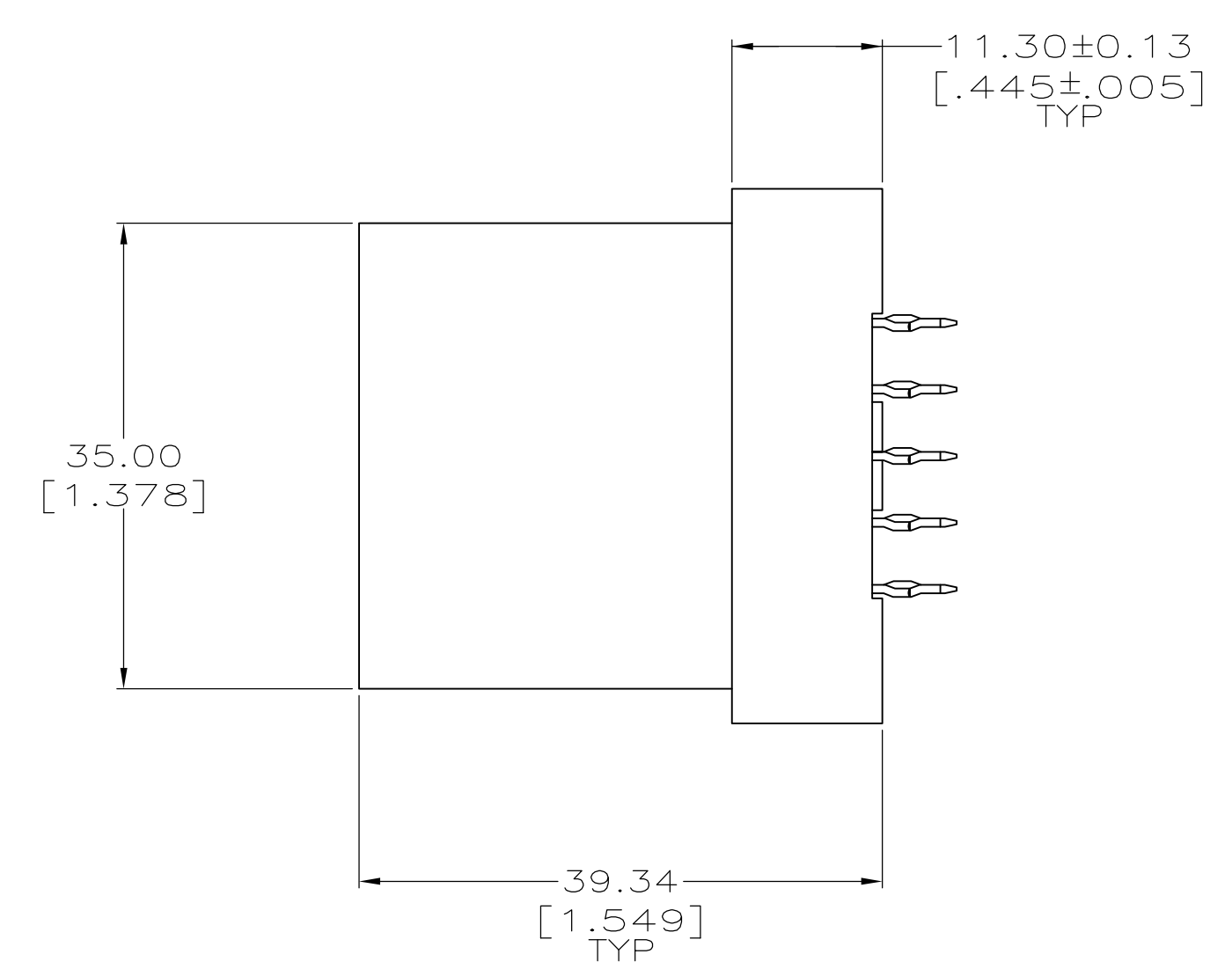
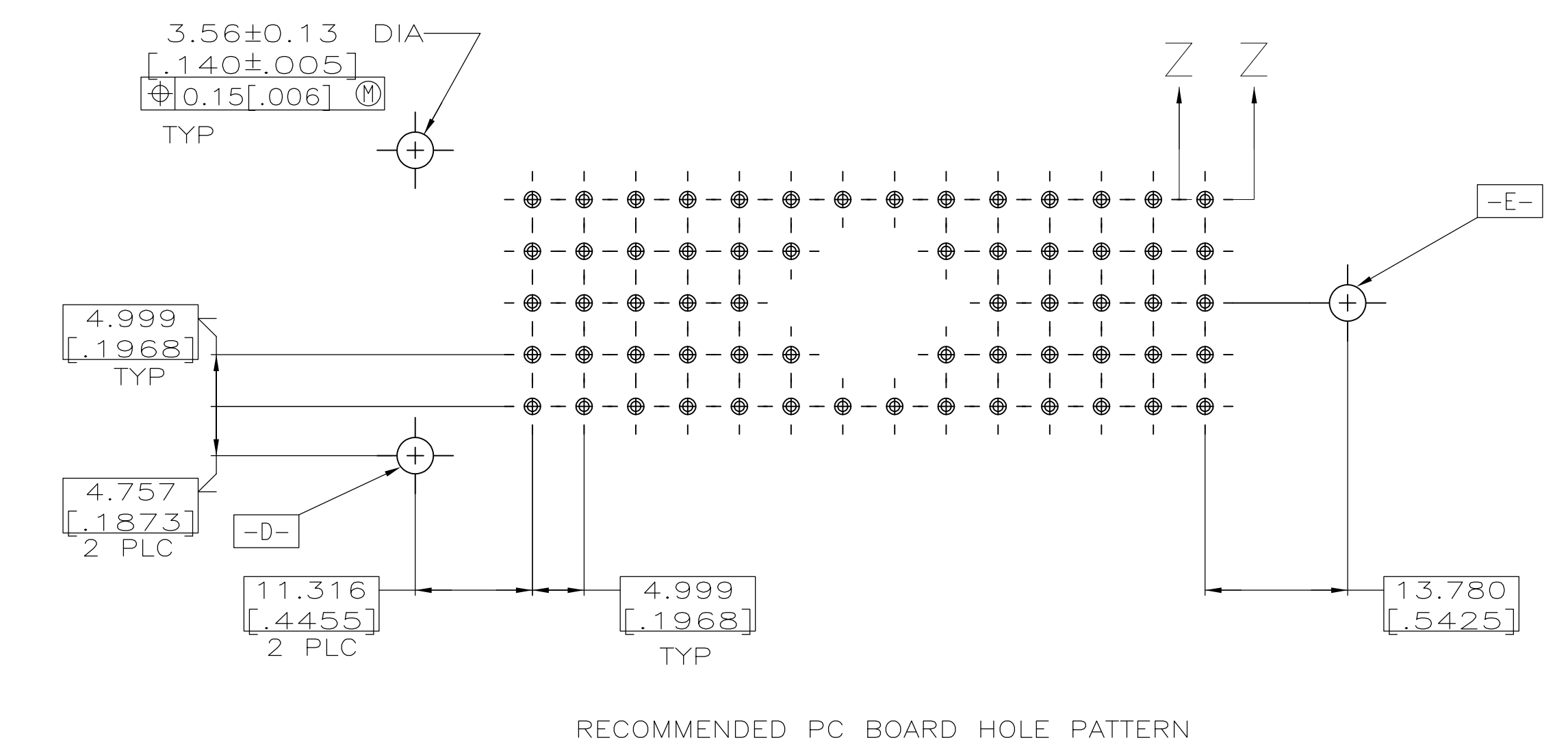
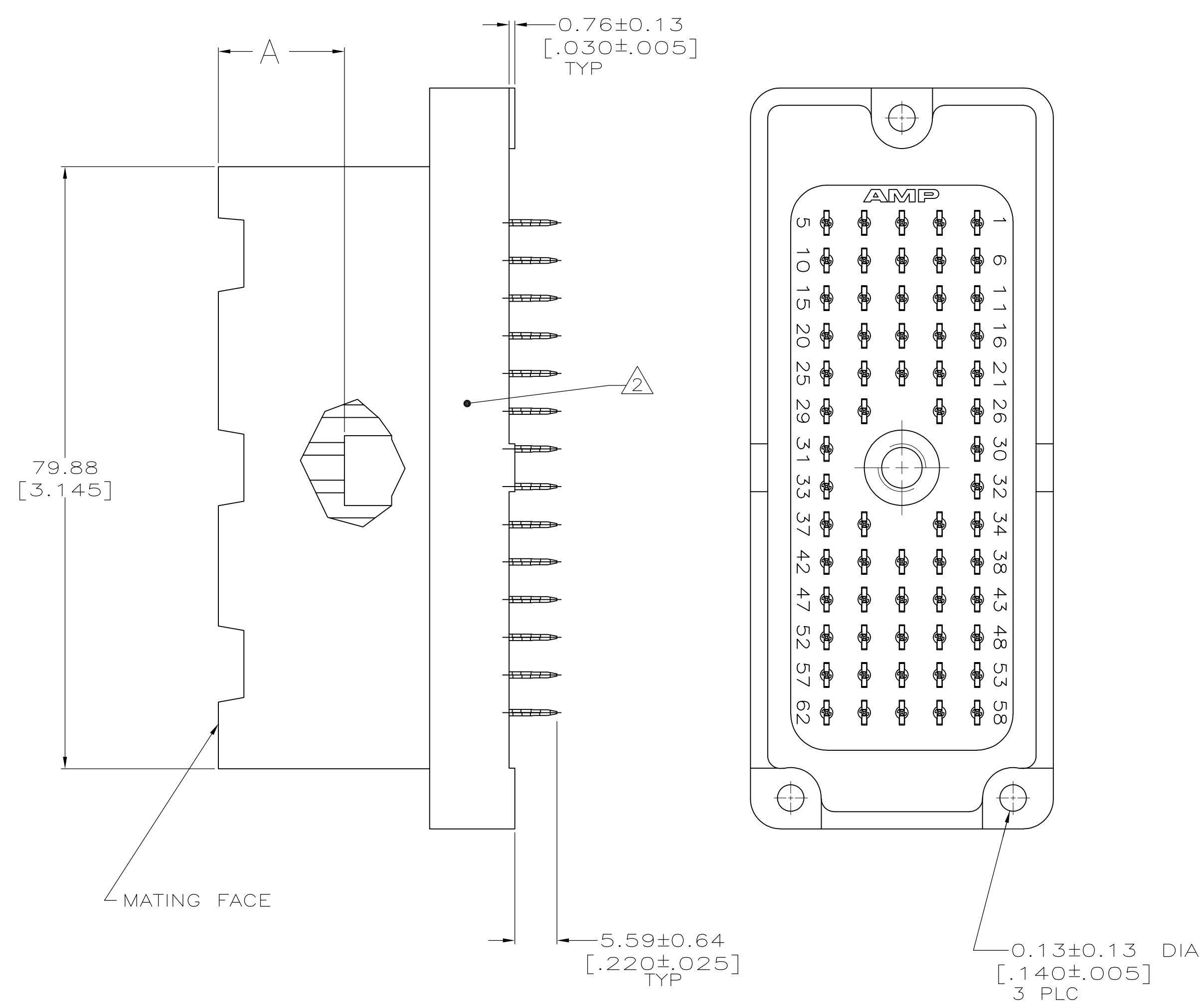
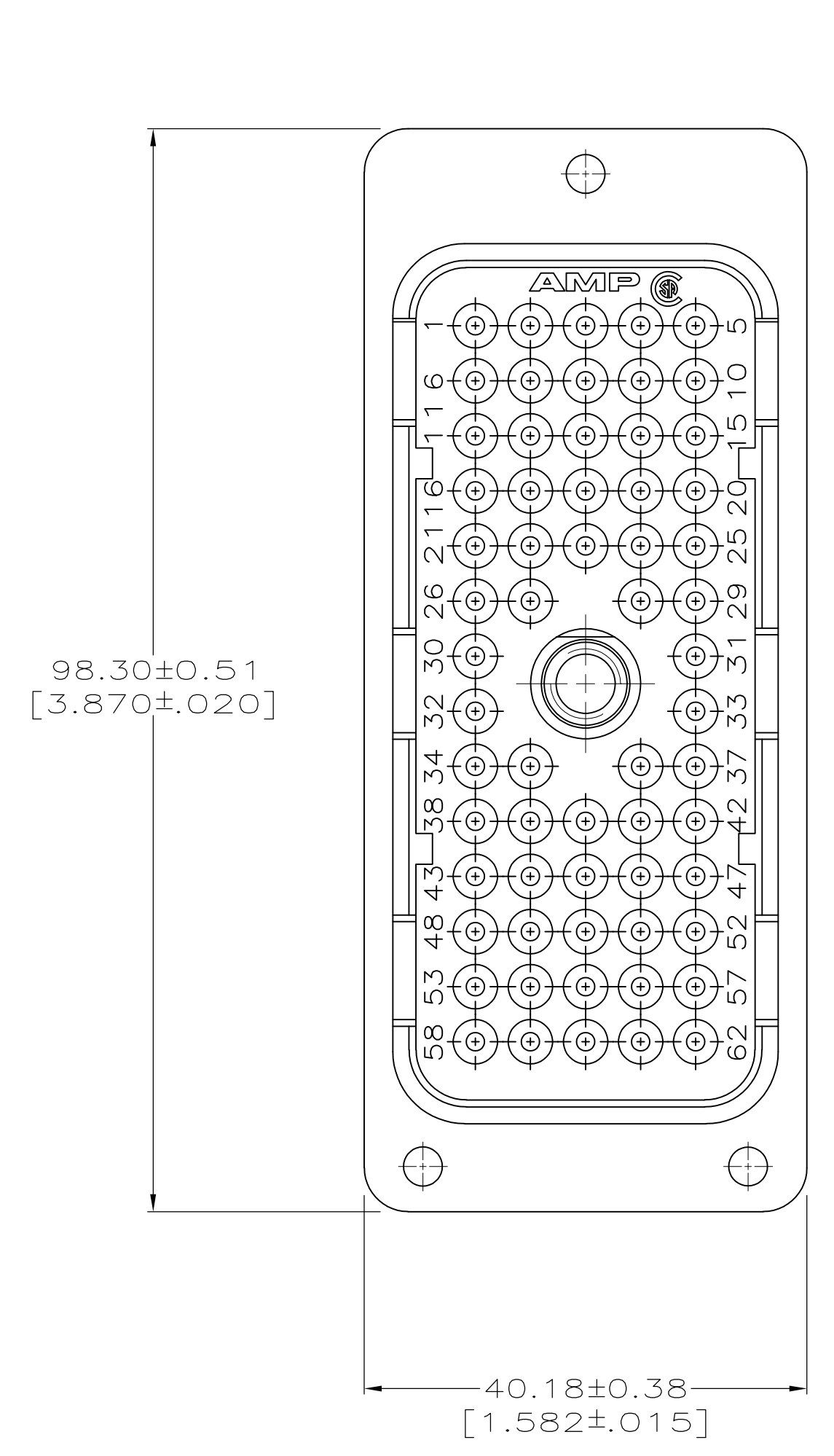

- ① 0.76μm[.000030] MIN GOLD FOR A LENGTH OF 5.46[.215] MIN FROM MATING END, 3.81μm[.000150] MIN TIN-LEAD ON OPPOSITE END FOR A LENGTH OF 5.08[.200] MIN, BOTH OVER 1.27μm[.000050] MIN NICKEL.
- ② AMP PART NUMBER AND DATE CODE MARKED IN THIS AREA.
- ③ 0.76μm[.000030] MIN GOLD FOR A LENGTH OF 7.62[.300] MIN FROM MATING END, 3.81μm[.000150] MIN TIN-LEAD ON OPPOSITE END FOR A LENGTH OF 5.08[.200] MIN, BOTH OVER 1.27μm[.000050] MIN NICKEL.
- ④ 0.76μm[.000030] MIN GOLD FOR A LENGTH OF 7.62[.300] MIN FROM MATING END, 3.81μm[.000150] MIN TIN-LEAD ON OPPOSITE END FOR A LENGTH OF 5.08[.200] MIN, BOTH OVER 1.27μm[.000050] MIN NICKEL.
- ⑤ OBSOLETE PARTS: OBSOLETE CIS STREAMLINING PER D.RENAUD/D.SINISI

5	OBSOLETE	6.60 [.260]	④	213788-3
		6.60 [.260]	③	213788-2
		17.53 [.690]	①	213788-1
SUPERSEDED BY 213788-2				
A	CONTACT FINISH			PART NUMBER

THIS DRAWING IS A CONTROLLED DOCUMENT.		DIN C. OBERMAN 1-5-94	Tyco Electronics Corporation Harrisburg, Pa 17105-3608	
DIMENSIONS: mm [INCHES]		CHK R. STONE 1-7-94	NAME	
TOLERANCES UNLESS OTHERWISE SPECIFIED:		APVD	PRODUCT SPEC	
0 PLC ± -	1 PLC ± -	APPLICATION SPEC		
2 PLC ± 0.25 [010]	3 PLC ± -	SIZE CASE CODE DRAWING NO		
4 PLC ± -	ANGLES ± -	RESTRICTED TO		
MATERIAL	FINISH	WEIGHT	A1 00779 C=213788	
CUSTOMER DRAWING		SCALE 2:1	SHEET 1 of 1	REV D1