



CYPRESS SEMICONDUCTOR

T-46-13-29

CY7C271
CY7C274

32,768 x 8 PROM Power Switched and Reprogrammable

Features

- CMOS for optimum speed/power
- Windowed for reprogrammability
- High speed
 - 30 ns (commercial)
 - 35 ns (military)
- Low power
 - 660 mW (commercial)
 - 715 mW (military)
- Super low standby power
 - Less than 165 mW when deselected
- EPROM technology 100% programmable
- Slim 300-mil package (7C271)
- Direct replacement for bipolar PROMs

- Capable of withstanding >2001V static discharge

Functional Description

The CY7C271 and CY7C274 are high-performance 32,768-word by 8-bit CMOS PROMs. When disabled (CE HIGH), the 7C271/7C274 automatically powers down into a low-power stand-by mode. The CY7C271 is packaged in the 300-mil slim package. The CY7C274 is packaged in the industry standard 600-mil package. Both the 7C271 and 7C274 are available in a cerDIP package equipped with an erasure window to provide for reprogrammability. When exposed to UV light, the PROM is erased and can be reprogrammed. The memory cells utilize proven EPROM floating gate technology and byte-wide intelligent programming algorithms.

The CY7C271 and CY7C274 offer the advantage of lower power, superior performance, and programming yield. The EPROM cell requires only 12.5V for the super voltage, and low current requirements allow for gang programming. The EPROM cells allow each memory location to be tested 100% because each location is written into, erased, and repeatedly exercised prior to encapsulation. Each PROM is also tested for AC performance to guarantee that after customer programming, the product will meet DC and AC specification limits.

Reading the 7C271 is accomplished by placing active LOW signals on CS₁ and CE, and an active HIGH on CS₂. Reading the 7C274 is accomplished by placing active LOW signals on OE and CE. The contents of the memory location addressed by the address lines (A₀ - A₁₄) will become available on the output lines (O₀ - O₇).

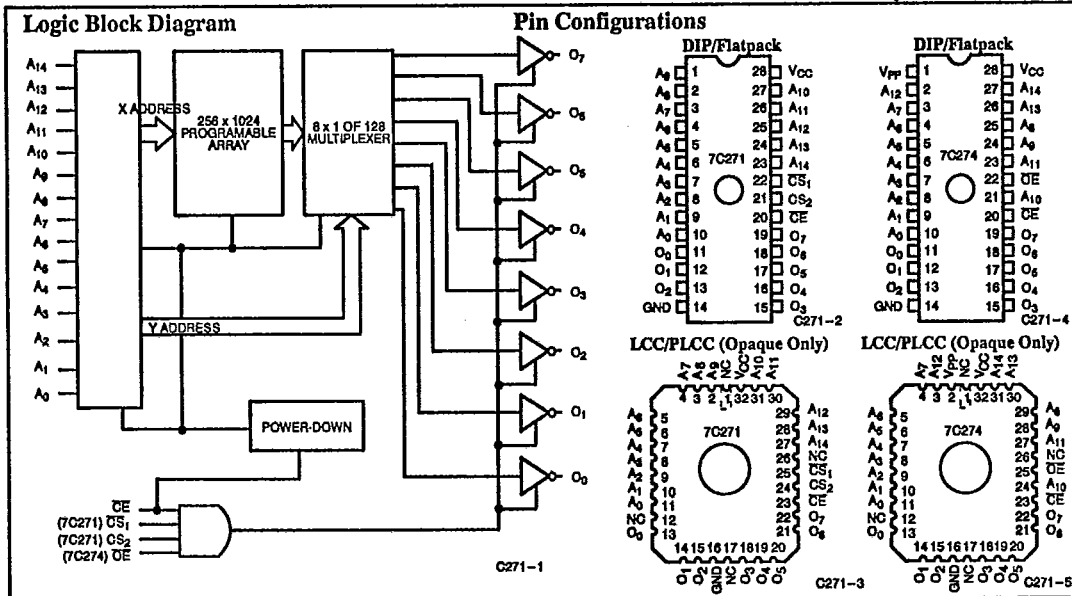

Selection Guide

	7C271-30 7C274-30	7C271-35 7C274-35	7C271-45 7C274-45	7C271-55 7C274-55
Maximum Access Time (ns)	30	35	45	55
Maximum Operating Current (mA)	Com'l	120	120	120
	Military	130	130	130
Standby Current (mA)	Com'l	30	30	30
	Military	40	40	40



T-46-13-29

CY7C271
CY7C274

Maximum Ratings

(Above which the useful life may be impaired. For user guidelines, not tested.)

- Storage Temperature - 65°C to +150°C
- Ambient Temperature with Power Applied - 55°C to +125°C
- Supply Voltage to Ground Potential - 0.5V to +7.0V
- DC Voltage Applied to Outputs in High Z State - 0.5V to +7.0V
- DC Input Voltage - 3.0V to +7.0V
- DC Program Voltage 13.0V
- Static Discharge Voltage (per MIL-STD-883, Method 3015) >2001V

- Latch-Up Current >200 mA
- UV Exposure 7258 Wsec/cm²

Operating Range

Range	Ambient Temperature	V _{CC}
Commercial	0°C to +70°C	5V ±10%
Industrial ^[1]	- 40°C to +85°C	5V ±10%
Military ^[2]	- 55°C to +125°C	5V ±10%



PROMS

Electrical Characteristics Over the Operating Range^[3]

Parameters	Description	Test Conditions	7C271-30, 35, 45, 55 7C274-30, 35, 45, 55		Units
			Min.	Max.	
V _{OH}	Output HIGH Voltage	V _{CC} = Min., I _{OH} = - 2.0 mA	2.4		V
V _{OL}	Output LOW Voltage	V _{CC} = Min., I _{OL} = 8.0 mA ^[4]		0.4	V
V _{IH}	Input HIGH Level	Guaranteed Input Logical HIGH Voltage for All Inputs	2.0	V _{CC}	V
V _{IL}	Input LOW Level	Guaranteed Input Logical LOW Voltage for All Inputs		0.8	V
I _{IX}	Input Current	GND ≤ V _{IN} ≤ V _{CC}	- 10	+ 10	µA
I _{OZ}	Output Leakage Current	V _{OL} ≤ V _{OUT} ≤ V _{OH} , Output Disabled	- 40	+ 40	µA
I _{OS}	Output Short Circuit Current ^[5]	V _{CC} = Max., V _{OUT} = GND	- 20	- 90	mA
I _{CC}	Power Supply Current	V _{CC} = Max., V _{IN} = 2.0V, I _{OUT} = 0 mA	Commercial	120	mA
			Military	130	
I _{SB}	Standby Supply Current	V _{CC} = Max., CS ≥ V _{IH} , I _{OUT} = 0 mA	Commercial	30	mA
			Military	40	
V _{PP}	Programming Supply Voltage		12	13	V
I _{PP}	Programming Supply Current			50	mA
V _{IHP}	Input HIGH Programming Voltage		3.0		V
V _{ILP}	Input LOW Programming Voltage			0.4	V

Capacitance^[6]

Parameters	Description	Test Conditions	Max.	Units
C _{IN}	Input Capacitance	T _A = 25°C, f = 1 MHz, V _{CC} = 5.0V	10	pF
C _{OUT}	Output Capacitance		10	pF

- Notes:
1. Contact a Cypress representative for information on industrial temperature range specifications.
 2. T_A is the "instant on" case temperature.
 3. See the last page of this specification for Group A subgroup testing information.
 4. 6.0 mA military
 5. For test purposes, not more than one output at a time should be shorted. Short circuit test duration should not exceed 30 seconds.
 6. See Introduction to CMOS PROMS in this Data Book for general information on testing.



T-46-13-29

AC Test Loads and Waveforms^[6]

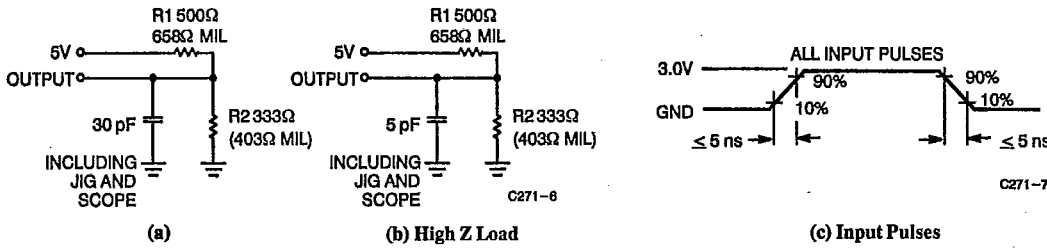

Equivalent to: THÉVENIN EQUIVALENT

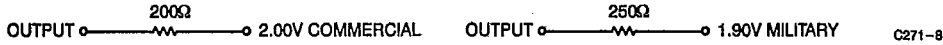

Switching Characteristics Over the Operating Range^[3, 6]

Parameters	Description	7C271-30 7C274-30		7C271-35 7C274-35		7C271-45 7C274-45		7C271-55 7C274-55		Units
		Min.	Max.	Min.	Max.	Min.	Max.	Min.	Max.	
t_{AA}	Address to Output Valid		30		35		45		55	ns
t_{HZCS}	Chip Select Inactive to High Z (\overline{CS}_1 and CS_2 , 7C271 Only)		20		25		30		30	ns
t_{ACS}	Chip Select Active to Output Valid (\overline{CS}_1 and CS_2 , 7C271 Only)		20		25		30		30	ns
t_{HZOE}	Output Enable Inactive to High Z (\overline{OE} , 7C274 Only)		20		25		25		30	ns
t_{OE}	Output Enable Active to Output Valid (\overline{OE} , 7C274 Only)		20		25		25		30	ns
t_{HZCE}	Chip Enable Inactive to High Z (\overline{CE} Only)		35		40		50		60	ns
t_{ACE}	Chip Enable Active to Output Valid (\overline{CE} Only)		35		40		50		60	ns
t_{PU}	Chip Enable Active to Power Up	0		0		0		0		ns
t_{PD}	Chip Enable Inactive to Power Down		35		40		50		60	ns
t_{OH}	Output Hold from Address Change	0		0		0		0		ns

Switching Waveform

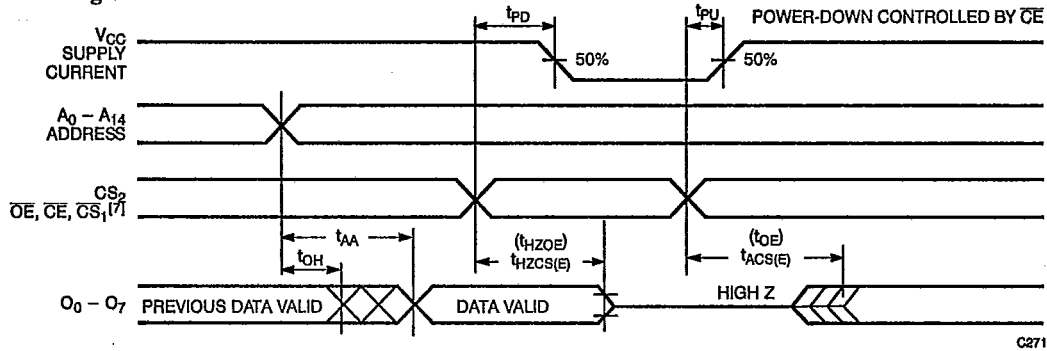

Notes:
7. CS_2 and \overline{CS}_1 are used on the 7C271 only. \overline{OE} is used on the 7C274 only.



T-46-13-29

CY7C271
CY7C274

Erasure Characteristics

Wavelengths of light less than 4000 angstroms begin to erase the 7C271 and 7C274 in the windowed package. For this reason, an opaque label should be placed over the window if the PROM is exposed to sunlight or fluorescent lighting for extended periods of time.

The recommended dose of ultraviolet light for erasure is a wavelength of 2537 angstroms for a minimum dose (UV intensity x exposure time) or 25 Wsec/cm². For an ultraviolet lamp with a 12 mW/cm² power rating, the exposure time would be approximately 45 minutes. The 7C271 or 7C274 needs to be within 1 inch of the

lamp during erasure. Permanent damage may result if the PROM is exposed to high-intensity UV light for an extended period of time. 7258 Wsec/cm² is the recommended maximum dosage.

Programming Modes

Programming support is available from Cypress as well as from a number of third-party software vendors. For detailed programming information, including a listing of software packages, please see the PROM Programming Information located at the end of this section. Programming algorithms can be obtained from any Cypress representative.



Table 1. CY7C271 Mode Selection

Mode	Pin Function ⁽⁸⁾					
	Read or Output Disable	A ₁₄ - A ₀	CE	CS ₂	CS ₁	O ₇ - O ₀
	Other	A ₁₄ - A ₀	VFY	PGM	VPP	D ₇ - D ₀
Read		A ₁₄ - A ₀	VIL	VIH	VIL	O ₇ - O ₀
Power Down		A ₁₄ - A ₀	VIH	X	X	High Z
Output Disable		A ₁₄ - A ₀	X	VIL	X	High Z
Output Disable		A ₁₄ - A ₀	X	X	VIH	High Z
Program		A ₁₄ - A ₀	VIHP	VILP	VPP	D ₇ - D ₀
Program Verify		A ₁₄ - A ₀	VILP	VIHP/VILP	VPP	O ₇ - O ₀
Program Inhibit		A ₁₄ - A ₀	VIHP	VIHP	VPP	High Z
Blank Check		A ₁₄ - A ₀	VILP	VIHP/VILP	VPP	O ₇ - O ₀

Table 2. CY7C274 Mode Selection

Mode	Pin Function ⁽⁸⁾					
	Read or Output Disable	A ₁₄ - A ₀	OE	CE	VPP	O ₇ - O ₀
	Other	A ₁₄ - A ₀	VFY	PGM	VPP	D ₇ - D ₀
Read		A ₁₄ - A ₀	VIL	VIL	X	O ₇ - O ₀
Output Disable		A ₁₄ - A ₀	VIH	X	X	High Z
Power Down		A ₁₄ - A ₀	X	VIH	X	High Z
Program		A ₁₄ - A ₀	VIHP	VILP	VPP	D ₇ - D ₀
Program Verify		A ₁₄ - A ₀	VILP	VIHP/VILP	VPP	O ₇ - O ₀
Program Inhibit		A ₁₄ - A ₀	VIHP	VIHP	VPP	High Z
Blank Check		A ₁₄ - A ₀	VILP	VIHP/VILP	VPP	O ₇ - O ₀

Note:
8. X = "don't care" but not to exceed V_{CC} ±5%.



T-46-13-29

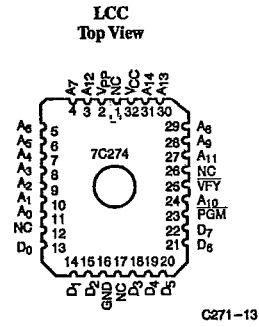
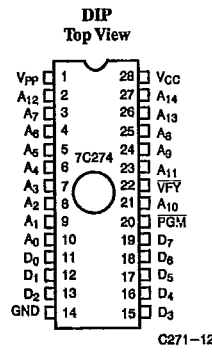
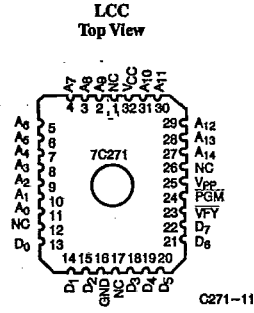
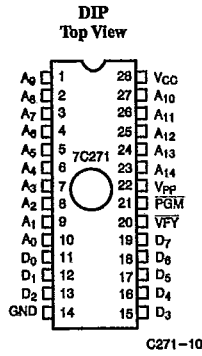
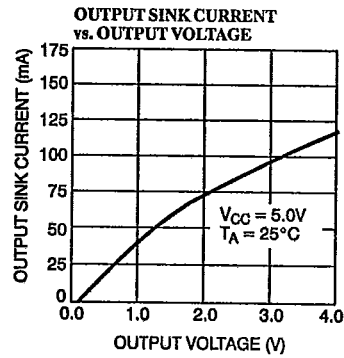
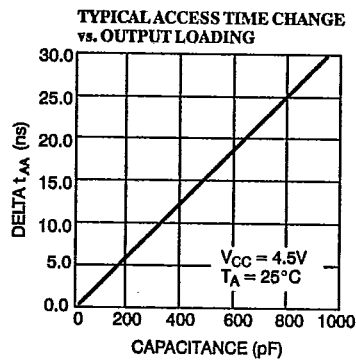
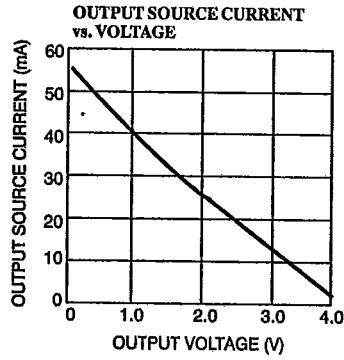
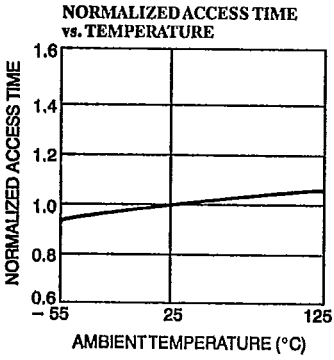
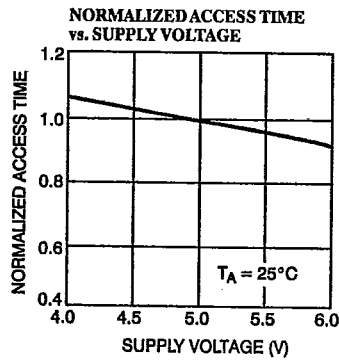
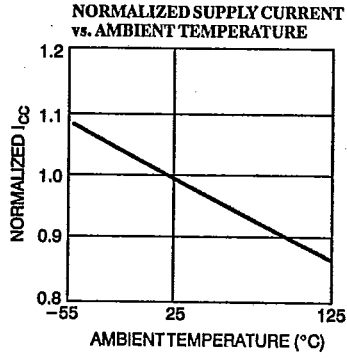
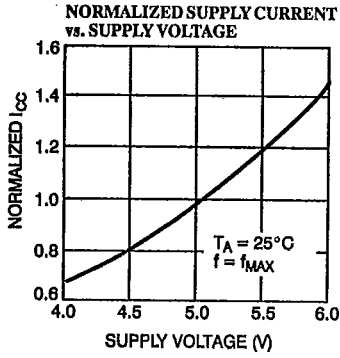

Figure 1. Programming Pinouts



Typical DC and AC Characteristics





T-46-13-29

Ordering Information⁽⁹⁾

Speed (ns)	Ordering Code	Package Type	Operating Range
30	CY7C271-30DC	D16	Commercial
	CY7C271-30JC	J65	
	CY7C271-30WC	W22	
35	CY7C271-35DC	D22	Commercial
	CY7C271-35JC	J65	
	CY7C271-35PC	P21	
	CY7C271-35WC	W22	Military
	CY7C271-35DMB	D22	
	CY7C271-35KMB	K74	
	CY7C271-35LMB	L55	
	CY7C271-35QMB	Q55	
	CY7C271-35WMB	W22	
45	CY7C271-45DC	D22	Commercial
	CY7C271-45JC	J65	
	CY7C271-45PC	P21	
	CY7C271-45WC	W22	Military
	CY7C271-45DMB	D22	
	CY7C271-45KMB	K74	
	CY7C271-45LMB	L55	
	CY7C271-45QMB	Q55	
	CY7C271-45TMB	T74	
CY7C271-45WMB	W22		
55	CY7C271-55DC	D22	Commercial
	CY7C271-55JC	J65	
	CY7C271-55PC	P21	
	CY7C271-55WC	W22	Military
	CY7C271-55DMB	D22	
	CY7C271-55KMB	K74	
	CY7C271-55LMB	L55	
	CY7C271-55QMB	Q55	
	CY7C271-55TMB	T74	
CY7C271-55WMB	W22		

Speed (ns)	Ordering Code	Package Type	Operating Range
30	CY7C274-30DC	D16	Commercial
	CY7C274-30JC	J65	
	CY7C274-30PC	P15	
	CY7C274-30WC	W16	
35	CY7C274-35DC	D16	Commercial
	CY7C274-35JC	J65	
	CY7C274-35PC	P15	
	CY7C274-35WC	W16	Military
	CY7C274-35DMB	D16	
	CY7C274-35KMB	K74	
	CY7C274-35LMB	L55	
	CY7C274-35QMB	Q55	
	CY7C274-35TMB	T74	
	CY7C274-35WMB	W16	
45	CY7C274-45DC	D22	Commercial
	CY7C274-45JC	J65	
	CY7C274-45PC	P15	
	CY7C274-45WC	W16	Military
	CY7C274-45DMB	D16	
	CY7C274-45KMB	K74	
	CY7C274-45LMB	L55	
	CY7C274-45QMB	Q55	
	CY7C274-45TMB	T74	
	CY7C274-45WMB	W16	
55	CY7C274-55DC	D16	Commercial
	CY7C274-55JC	J65	
	CY7C274-55PC	P15	
	CY7C274-55WC	W16	Military
	CY7C274-55DMB	D16	
	CY7C274-55KMB	K74	
	CY7C274-55LMB	L55	
	CY7C274-55QMB	Q55	
	CY7C274-55TMB	T74	
CY7C274-55WMB	W16		

Note:
9. Most of these products are available in industrial temperature range. Contact a Cypress representative for specifications and product availability.



CY7C271
CY7C274

T-46-13-29

MILITARY SPECIFICATIONS
Group A Subgroup Testing

DC Characteristics

Parameters	Subgroups
V _{OH}	1, 2, 3
V _{OL}	1, 2, 3
V _{IH}	1, 2, 3
V _{IL}	1, 2, 3
I _{Ix}	1, 2, 3
I _{OZ}	1, 2, 3
I _{CC}	1, 2, 3
I _{SB}	1, 2, 3



Switching Characteristics

Parameters	Subgroups
t _{AA}	7, 8, 9, 10, 11
t _{ACS1} ^[10]	7, 8, 9, 10, 11
t _{OE} ^[11]	7, 8, 9, 10, 11
t _{ACE}	7, 8, 9, 10, 11

Notes:

10. 7C274 and 7C271 (\overline{CS}_2 , CS₃ and \overline{CS}_4 only).

11. 7C271 only.

SMD Cross Reference

SMD Number	Suffix	Cypress Number
5962-89817	01XX	CY7C271-55WMB
5962-89817	01YX	CY7C271-55TMB
5962-89817	01ZX	CY7C271-55QMB
5962-89817	02XX	CY7C271-45WMB
5962-89817	02YX	CY7C271-45TMB
5962-89817	02ZX	CY7C271-45QMB

Document #: 38-00068-F