

HC3

High current power inductors



Product description

- Compact footprint
- Designed for high density, high current/low voltage applications
- Foil technology that adds higher reliability factor over the traditional magnet wire used for higher frequency circuit designs
- Inductance range from 0.50uH to 6.52uH
- Current range from 30 to 120 Amps
- Ferrite core material

Applications

- Distributed power systems DC-DC converters
- General-purpose low voltage supplies
- Computer systems
- Servers
- Point of Load (POL) converters
- Industrial Equipment

Environmental data

- Storage temperature range (component): -40°C to +125°C
- Operating temperature range: -40°C to +125°C (ambient plus self-temperature rise)
- Solder reflow temperature: J-STD-020D compliant.

Packaging

- Supplied in bulk packaging, 24 parts per tray



Product specifications

Part number ⁵	OCL ¹ (μH) ±20%	I _{rms} ² (amps)	I _{sat} ³ (amps)	DCR (mΩ) maximum @ 20°C	Volt-μsec ⁴ (V-μs) ref.
HC3-R50-R	0.50	78.00	120	0.42	17.33
HC3-1R0-R	1.05	78.00	78	0.42	17.33
HC3-2R2-R	2.05	55.50	60	0.70	26.01
HC3-3R3-R	3.63	42.45	46	1.20	34.65
HC3-4R7-R	4.98	33.80	38	2.17	43.30
HC3-5R6-R	5.68	33.80	34.5	2.17	43.30
HC3-6R0-R	6.52	33.80	30.0	2.17	43.30

- OCL (Open Circuit Inductance) Test parameters: 300kHz, .25Vrms, 0.0ADC & Isat.
- DC current for approximately ΔT of 40°C without core loss De-rating is necessary for AC currents. PCB layout, trace thickness and width, air flow and proximity of other heat generating components will affect temperature rise. It is recommended that the temperature of the part not exceed 125°C under worst case conditions verified in the end application.
- Peak current for approximately 30% rolloff (@20°C).
- Applied Volt-Time product (V-μs) across the inductor. This value represents the applied V-μs at 300kHz necessary to generate a core loss equal to 10% of the total losses for a 40°C temperature rise.
- Part number definition - HC3-xxx-R:
 HC3 = Product code and size
 -xxx = Inductance value R = Decimal point (if no "R" is present, last character equals number of zeros)
 -R Suffix = RoHS compliant

Dimensions—mm

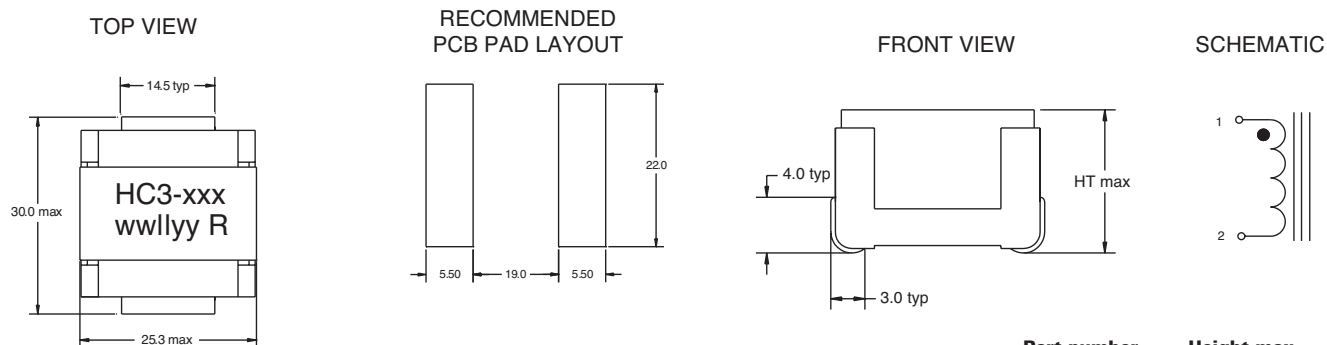

Part marking: HC3-xxx (-xxx= inductance value, R= decimal point, if no R is present then last character equals number of zeros)

wwllly= date code, R= Revision level

Part number	Height max
HC3-R50-R	18.0
HC3-1R0-R	17.5
HC3-2R2-R	17.5
HC3-3R3-R	17.5
HC3-4R7-R	17.5
HC3-5R6-R	17.5
HC3-6R0-R	17.5

Inductance characteristics

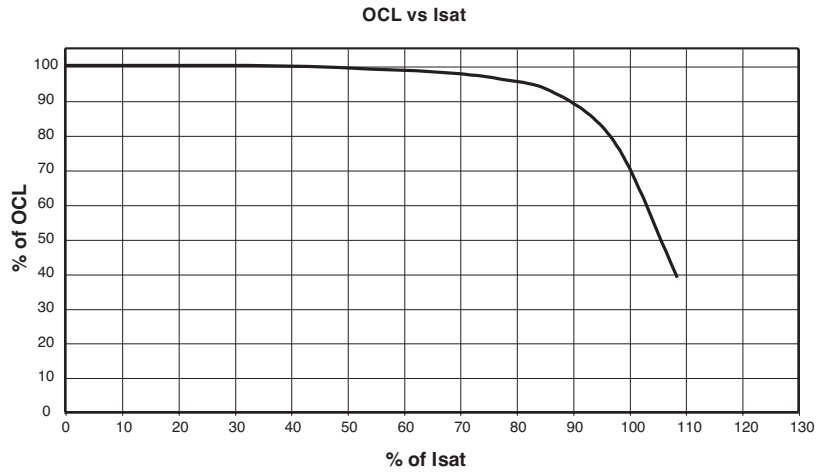

Core loss

Irms DERATING WITH CORE LOSS for HC3
% Applied Volt-u Seconds

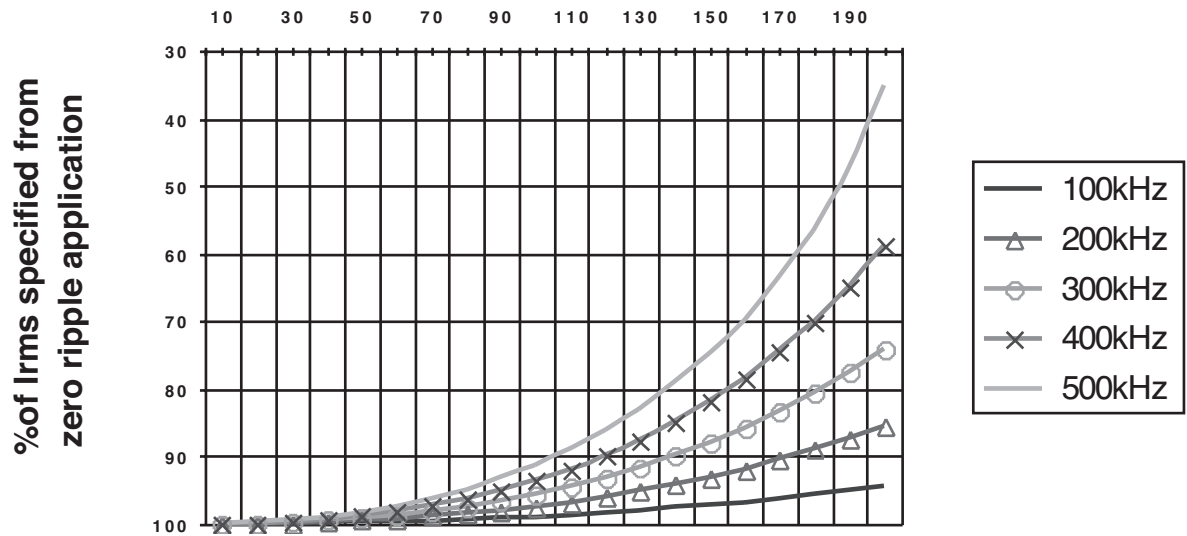

Solder reflow profile



Table 1 - Standard SnPb Solder (T_C)

Package Thickness	Volume mm ³ <350	Volume mm ³ ≥350
<2.5mm)	235°C	220°C
≥2.5mm	220°C	220°C

Table 2 - Lead (Pb) Free Solder (T_C)

Package Thickness	Volume mm ³ <350	Volume mm ³ 350 - 2000	Volume mm ³ >2000
<1.6mm	260°C	260°C	260°C
1.6 - 2.5mm	260°C	250°C	245°C
>2.5mm	250°C	245°C	245°C

Reference JDEC J-STD-020D

Profile Feature	Standard SnPb Solder	Lead (Pb) Free Solder
Preheat and Soak		
• Temperature min. (T _{smin})	100°C	150°C
• Temperature max. (T _{smax})	150°C	200°C
• Time (T _{smin} to T _{smax}) (t _s)	60-120 Seconds	60-120 Seconds
Average ramp up rate T _{smax} to T _p	3°C/ Second Max.	3°C/ Second Max.
Liquidous temperature (T _L)	183°C	217°C
Time at liquidous (t _L)	60-150 Seconds	60-150 Seconds
Peak package body temperature (T _p)*	Table 1	Table 2
Time (t _p)** within 5 °C of the specified classification temperature (T _C)	20 Seconds**	30 Seconds**
Average ramp-down rate (T _p to T _{smax})	6°C/ Second Max.	6°C/ Second Max.
Time 25°C to Peak Temperature	6 Minutes Max.	8 Minutes Max.

* Tolerance for peak profile temperature (T_p) is defined as a supplier minimum and a user maximum.

** Tolerance for time at peak profile temperature (t_p) is defined as a supplier minimum and a user maximum.

Life Support Policy: Eaton does not authorize the use of any of its products for use in life support devices or systems without the express written approval of an officer of the Company. Life support systems are devices which support or sustain life, and whose failure to perform, when properly used in accordance with instructions for use provided in the labeling, can be reasonably expected to result in significant injury to the user.

Eaton reserves the right, without notice, to change design or construction of any products and to discontinue or limit distribution of any products. Eaton also reserves the right to change or update, without notice, any technical information contained in this bulletin.

Eaton
Electronics Division
 1000 Eaton Boulevard
 Cleveland, OH 44122
 United States
www.eaton.com/electronics

© 2017 Eaton
 All Rights Reserved
 Printed in USA
 Publication No. 4122
 February 2017

Eaton is a registered trademark.

All other trademarks are property of their respective owners.