

MN6650A

Signal Processing LSI for CD Players

■ Overview

The MN6650A is a digital servo LSI for creating high-precision servo systems with completely self-adjusting focus, tracking, and traverse servos.

■ Features

- Focus servo
- Tracking servo
- Traverse servo
- Automatic adjustment functions for FO/TR gain, FO/TR offset, and FO/TR balance
- PWM output with tristate output from a single pin
- Built-in dropout countermeasures
- Anti-shock functions
- Support for both linear motor and screw-based traverse mechanisms
- Function to prevent runaway traverse operation
- Support for 3- and 1-beam systems
- Support for double-speed playback
- Microcomputer serial interface
- Operating voltage 4.5 to 5.5V

■ Applications

- CD Players

■ Pin Assignment

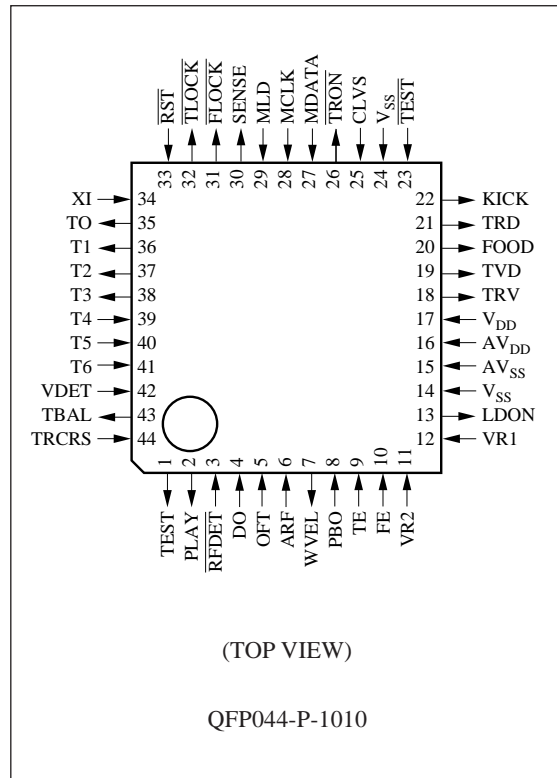

■ Block Diagram

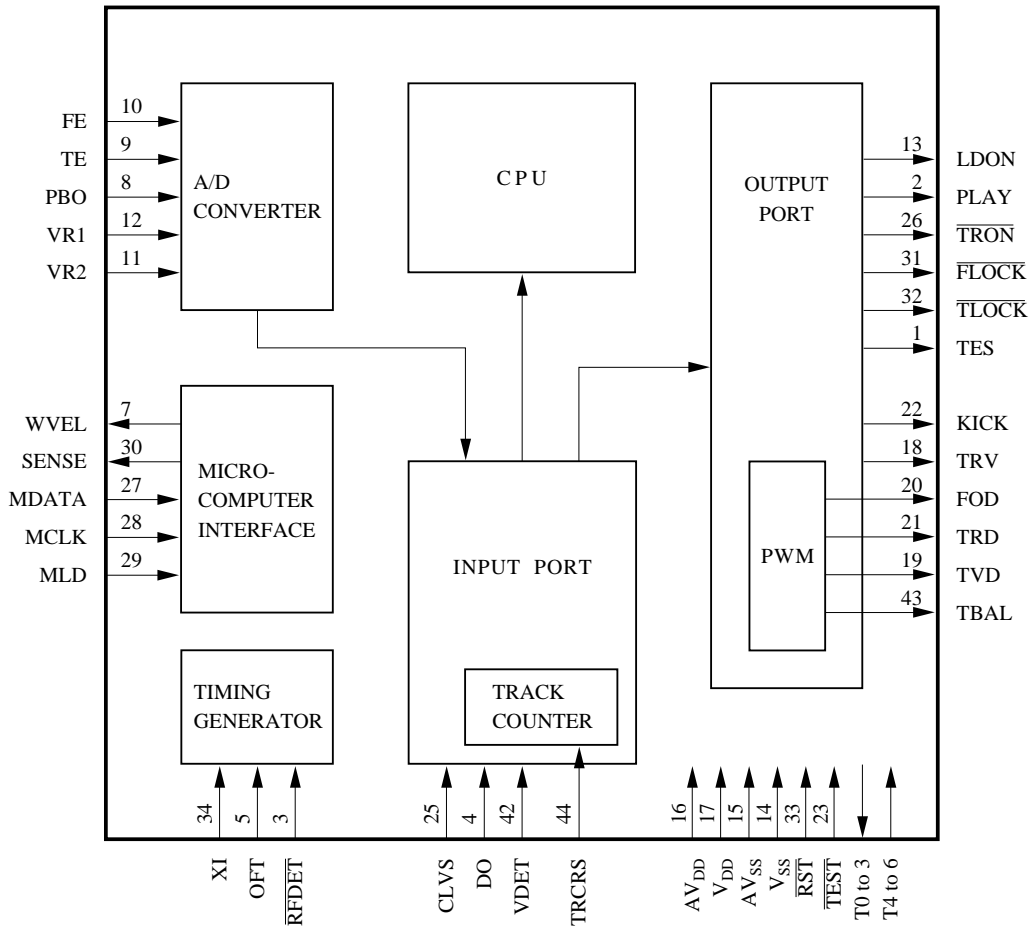

■ Pin Descriptions

Pin No.	Symbol	I/O	Function Description	
1	TES	O	Tracking error shunt signal.	"H" level: shunt.
2	PLAY	O	Play signal output.	"H" level: play.
3	$\overline{\text{RFDET}}$	I	RF detection signal input.	"L" level: detected.
4	DO	I	Dropout signal input.	"H" level: dropout
5	OFT	I	Offtrack signal input.	"H" level: offtrack.
6	ARF	I	RF signal input.	
7	WVEL	O	Double-speed status signal output.	"H" level: double-speed.
8	PBO	I	Potentiometer signal input.	(analog input)
9	TE	I	Tracking error signal input.	(analog input)
10	FE	I	Focus error signal input.	(analog input)
11	VR2	I	Reference voltage for A/D converter.	"L" level.
12	VR1	I	Reference voltage for A/D converter.	"H" level.
13	LDON	O	Laser ON signal output.	"H" level: ON.
14	V _{SS}	I	Ground for digital circuits. (0 V)	
15	AV _{SS}	I	Ground for analog circuits. (0 V)	
16	AV _{DD}	I	Power supply for analog circuits. (+5 V)	
17	V _{DD}	I	Power supply for digital circuits. (+5 V)	
18	TRV	O	Traverse forced feed output.	(tristate)
19	TVD	O	Traverse drive output.	(tristate)
20	FOD	O	Focus drive output.	(tristate)
21	TRD	O	Tracking drive output.	(tristate)
22	KICK	O	Kick pulse output.	(tristate)
23	$\overline{\text{TEST}}$	I	Test pin. Keep this at "H" level.	
24	V _{SS}	I	Ground for digital circuits. (0 V)	
25	CLVS	I	Spindle servo phase synchronization signal output.	"H" level: CLV. "L" level: rough servo.
26	$\overline{\text{TRON}}$	O	Tracking servo ON signal.	"L" level: ON.
27	MDATA	I	Microcomputer command data input.	
28	MCLK	I	Microcomputer command clock input. (Data is latched at rising edge.)	
29	MLD	I	Microcomputer command load signal input.	"L" level: load.
30	SENSE	O	Sense signal output. (OFT, FESL, NACEND, NAJEND, POSAD, and SFG)	
31	$\overline{\text{FLOCK}}$	O	Focus servo pull-in signal.	"L" level: pull-in state.
32	$\overline{\text{TLOCK}}$	O	Tracking servo pull-in signal.	"L" level: pull-in state.
33	$\overline{\text{RST}}$	I	Reset input.	"L" level: reset.
34	XI	I	Clock input. (f _{XI} = 16.9344 MHz) (Capacitor coupling requires a minimum of 1.0 V _{pp} .)	
35	T0	O	Test pin. Leave open.	
36	T1	O	Test pin. Leave open.	
37	T2	O	Test pin. Leave open.	
38	T3	O	Test pin. Leave open.	

■ Pin Descriptions (continued)

Pin No.	Symbol	I/O	Function Description
39	T4	I	Test pin. Keep this at "L" level.
40	T5	I	Test pin. Keep this at "L" level.
41	T6	I	Test pin. Keep this at "L" level.
42	VDET	I	Vibration detection signal input. "H" level: vibration detected.
43	TBAL	O	Tracking balance adjustment output. (tristate)
44	TRCRS	I	Track cross signal input.

■ Package Dimensions (Unit: mm)

QFP044-P-1010

