

M61539FP

6ch Electronic Volume with Tone Control

REJ03F0112-0100Z

Rev.1.0

Apr.16.2004

Description

The M61539FP is 6ch electronic volume with tone control. M61539FP is easy to use more than M62446AFP.

Features

- 6ch Electronic volume
Volume level: 0 to -95dB(1dB/step)
- Tone control
Bass/Treble: -14dB to +14dB(2dB/step)
- Noise voltage: 1.5 μ Vrms
- Bypass mode is high quality sound.

Recommended Operating Conditions

- Supply voltage range: 4.5 to ± 7.5 V (analog) (Single supply voltage 9 to 12V)
4.5 to 5.5V(digital)
- Rated supply voltage: ± 7.0 V(analog)
5.0V(digital)

System Block Diagram

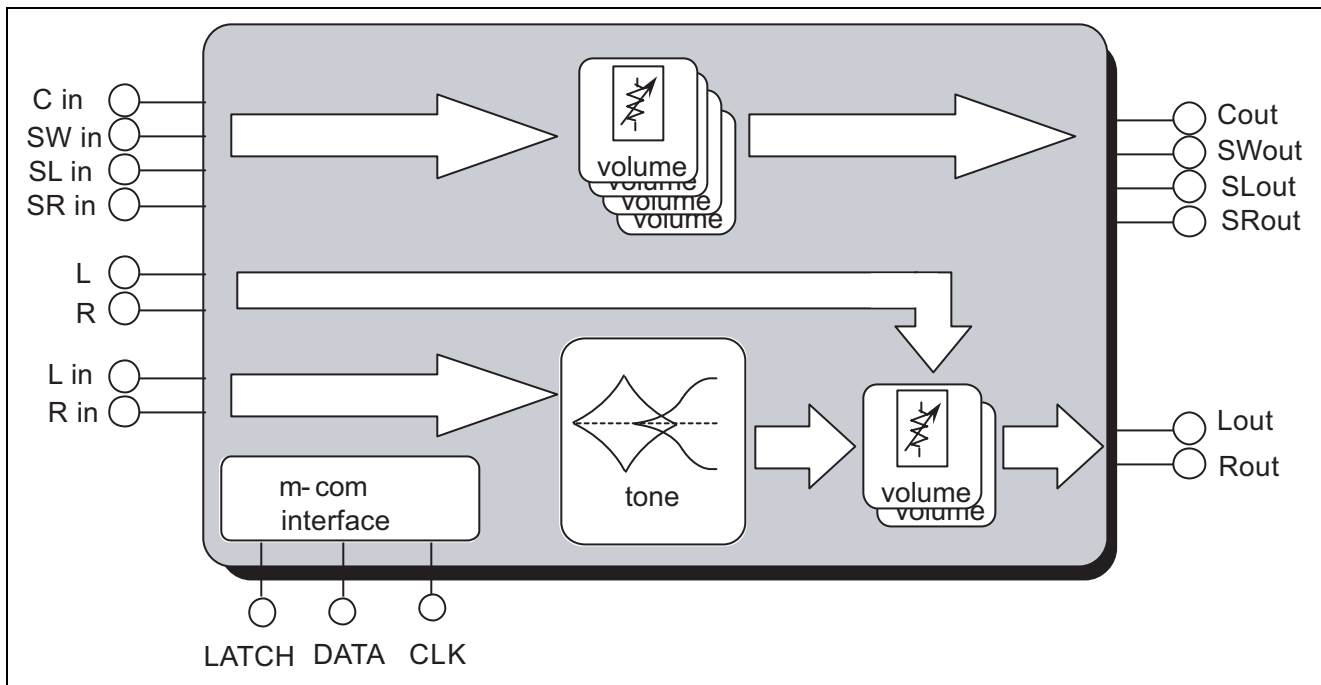

Pin Configuration and IC Internal Block Diagram

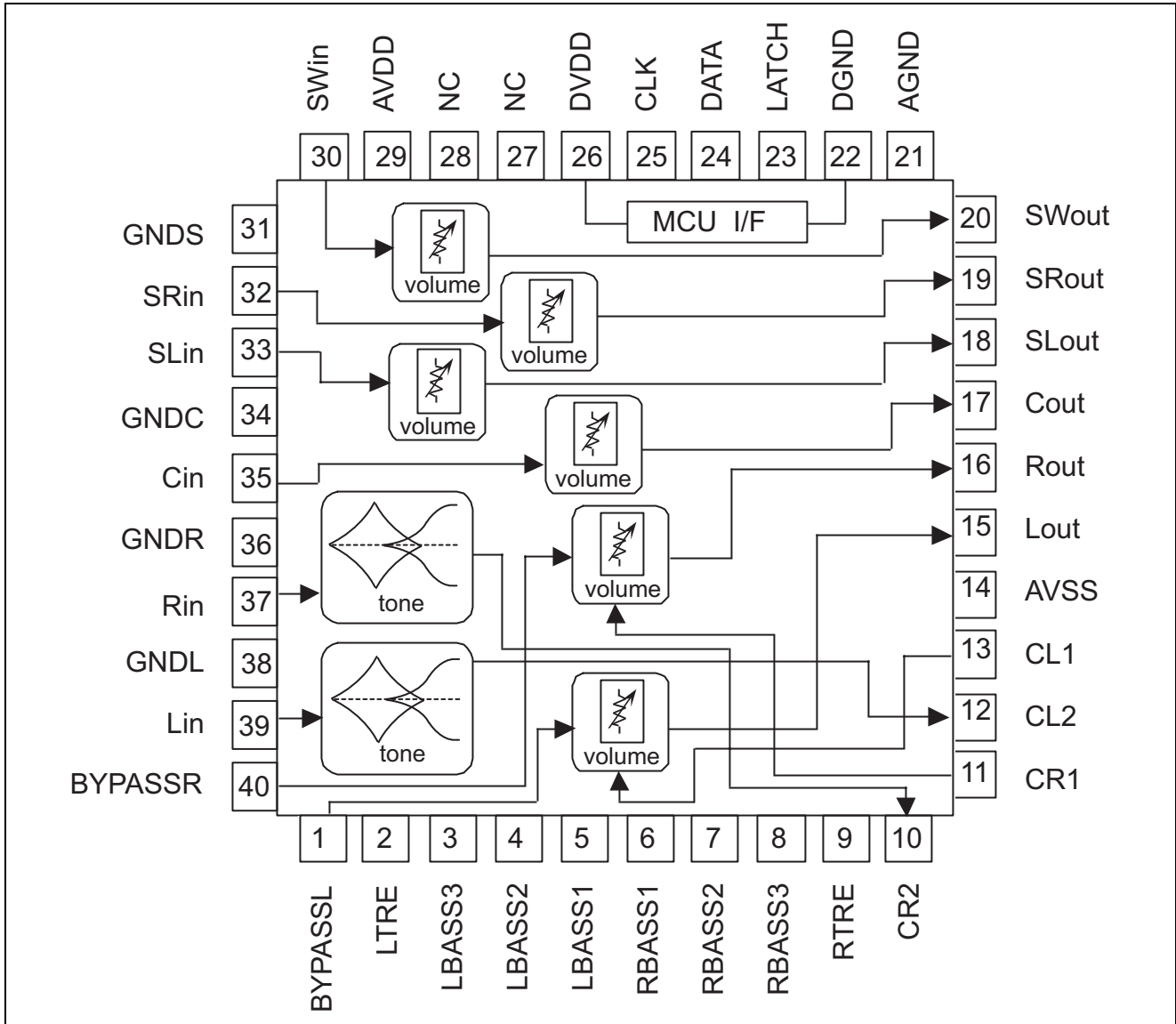

Pin Description

Pin No.	Symbol	Function	Circuit
29	AVDD	Analog positive Power supply	+7 V
31	GNDS	GND	Connect to analog GND
34	GNDC		
36	GNDR		
38	GNDL		
30	SWin	Volume INPUT	
32	SRin		
33	SLin		
35	Cin		
20	SWout		
19	SRout	Volume OUTPUT	
18	SLout		
17	Cout		
37	Rin		
39	Lin	Tone INPUT	
40	BYPASSR	L, R Volume INPUT in BYPASS mode	
1	BYPASSL		
15	Lout		
16	Rout		
2	LTRE	Tone Treble cycle control	
9	RTRE		
3	LBASS3	Tone Bass cycle control	
8	RBASS3		
4	LBASS2		
7	RBASS2		
5	LBASS1		
6	RBASS1		
10	CR2	Tone OUTPUT	
12	CL2		
11	CR1	L, R Volume INPUT	
13	CL1		
15	Lout		
16	Rout		
14	AVSS	Analog negative Power Supply	-7 V
21	AGND	Analog GND	
22	DGND	Digital GND	

M61539FP

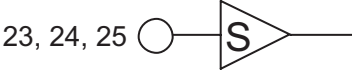
Pin No.	Symbol	Function	Circuit
23	LATCH	Latch INPUT	
24	DATA	Data INPUT	
25	CLK	Clock INPUT Forward data	
26	DVDD	Digital Power supply	+5 V

INPUT: Schmitt trigger type

Absolute Maximum Ratings

Parameter	Symbol	Ratings	Unit	Condition
Supply Voltage	Vsupply	16	V	AVDD-AVSS
		7		DVDD-DGND
Power dissipation	Pd	1460	mW	Ta ≤ 25°C
Thermal derating	Kθ	11.7	mW/°C	Ta > 25°C
Operating temperature	Topr	-20 to +75	°C	
Storage temperature	Tstg	-40 to +125	°C	

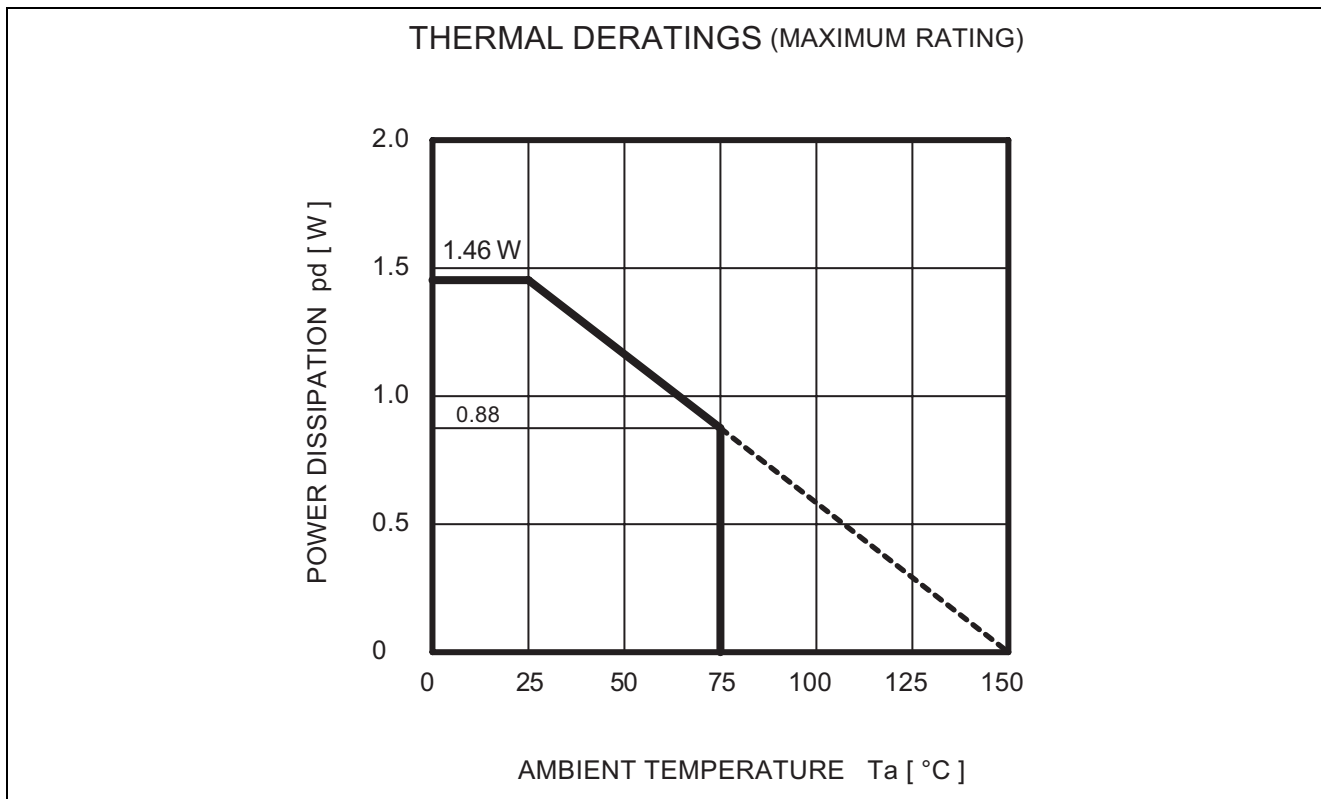

Recommended DC Operating Conditions

(Ta=25°C, unless otherwise noted.)

Parameter	Symbol	Min	Typ	Max	Unit	Condition
Analog positive Supply Voltage	AVDD	4.5	7.0	7.5	V	
Analog negative Supply Voltage	AVSS	-7.5	-7.0	-4.5	V	
Digital Supply Voltage	DVDD	4.5	5.0	5.5	V	
High-level Input Voltage	VIH	DVDD×0.7	—	DVDD	V	
Low-level Input Voltage	VIL	DGND	—	DVDD×0.3	V	

- Note: 1. AVSS≤DGND<DVDD≤AVDD
2. Apply AVDD, AVEE and DVDD at the same time.

Relationship between Data and clock and Latch

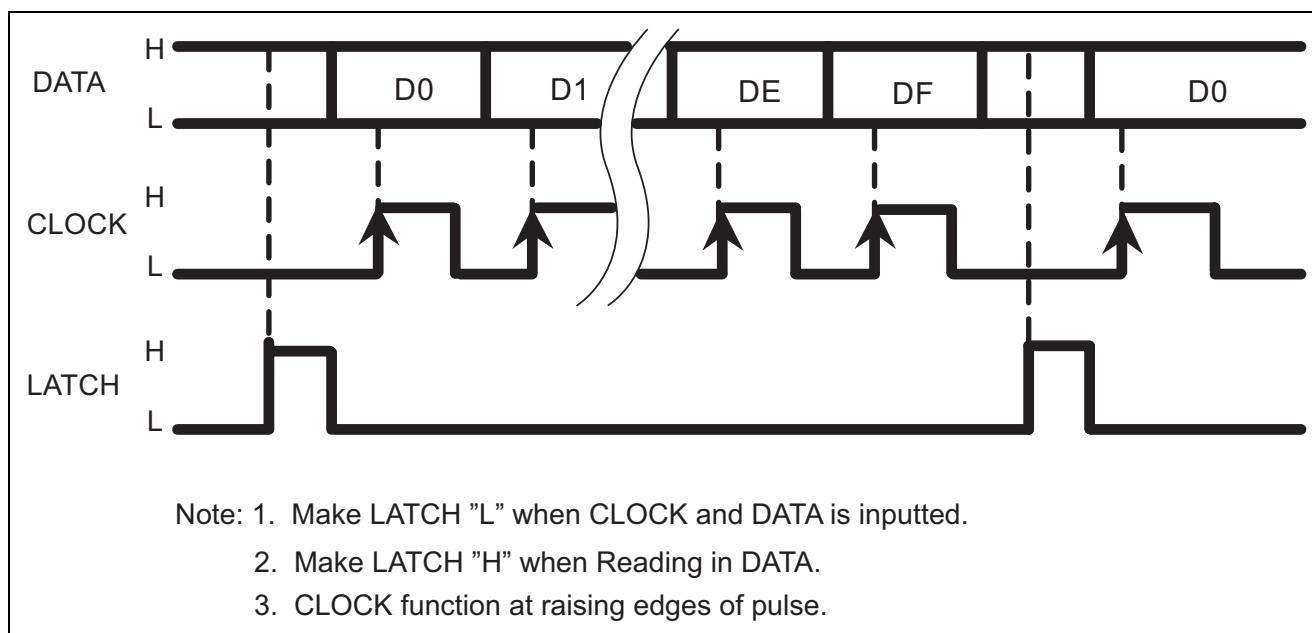

Data Timing (Recommended conditions)

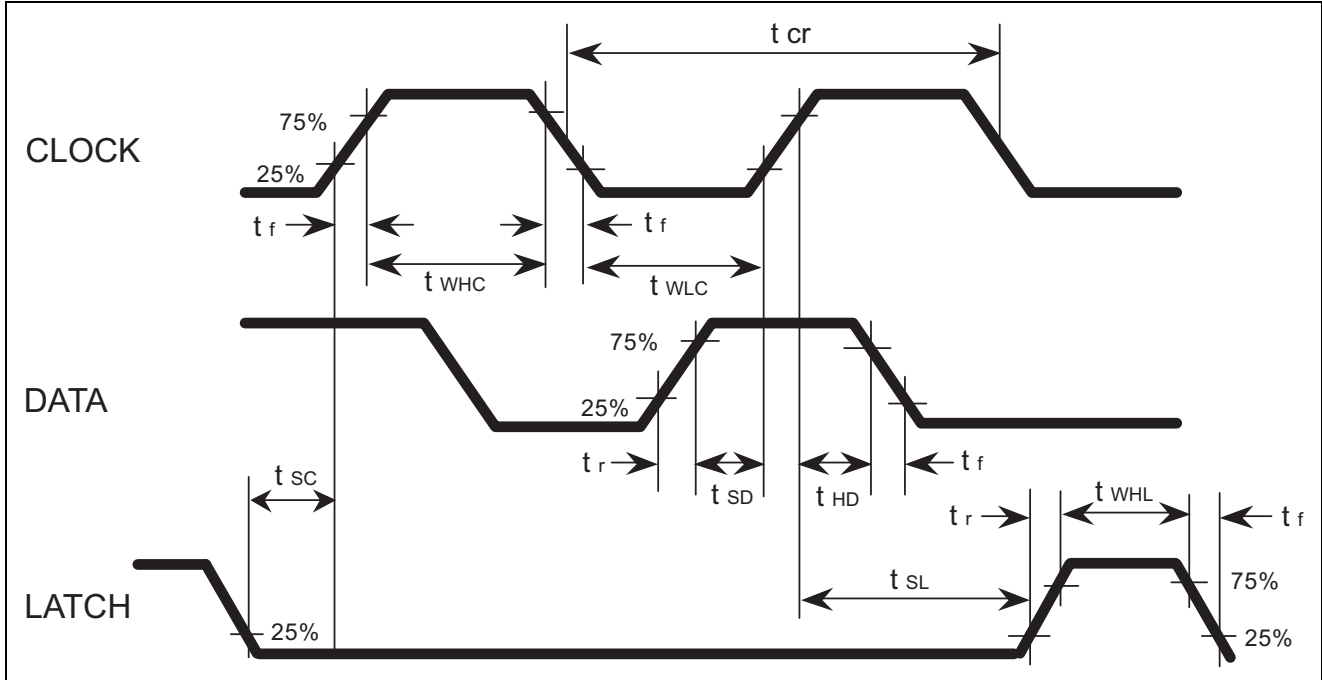

Digital Block Timing Regulation

Parameter	Symbol	Limits			Unit
		Min	Min	Max	
CLOCK cycle time	t_{cr}	8	—	—	
CLOCK pulse width ("H" level)	t_{WHC}	3.2	—	—	
CLOCK pulse width ("L" level)	t_{WLC}	3.2	—	—	
CLOCK, DATA, LATCH rise time	t_r	—	—	0.8	
CLOCK, DATA, LATCH fall time	t_f	—	—	0.8	μsec
DATA setup time	t_{SD}	1.6	—	—	
DATA hold time	t_{HD}	1.6	—	—	
LATCH setup time	t_{SL}	2	—	—	
LATCH pulse width	t_{WHL}	3.2	—	—	
CLOCK start time after LATCH	t_{SC}	3.2	—	—	

Digital Control Specification

Four kinds of input format options are available by changing slot settings of DE and DF.

(When the IC is powered up, the internal settings are not fixed.)

(1)	D01	D11	D21	D31	D41	D51	D61	D71	D81	D91	DA1	DB1	DC1	DD1	DE	DF	
	TONE CONT TLEBLE				0	0	0	0	TONE CONT BASS				0	TONE :0 BYPASS :1	0	0	
(2)	D02	D12	D22	D32	D42	D52	D62	D72	D82	D92	DA2	DB2	DC2	DD2	DE	DF	
	VOLUME Lch								VOLUME Rch								0
(3)	D03	D13	D23	D33	D43	D53	D63	D73	D83	D93	DA3	DB3	DC3	DD3	DE	DF	
	VOLUME Cch								VOLUME SWch								1
(4)	D04	D14	D24	D34	D44	D54	D64	D74	D84	D94	DA4	DB4	DC4	DD4	DE	DF	
	VOLUME SLch								VOLUME SRch								1

Setting Code

(1) Tone control (bass / treble)

ATT	Treble	D01	D11	D21	D31
	Bass	D81	D91	DA1	DB1
-14dB		1	1	1	1
-12dB		1	1	0	1
-10dB		1	1	1	0
-8dB		1	1	0	0
-6dB		1	0	1	1
-4dB		1	0	1	0
-2dB		1	0	0	1
+0dB		0	0	0	0
+2dB		0	0	0	1
+4dB		0	0	1	0
+6dB		0	0	1	1
+8dB		0	1	0	0
+10dB		0	1	1	0
+12dB		0	1	0	1
+14dB		0	1	1	1

(2) BYPASS control

DD1	
BYPASS	1
TONE	0

(3)-1 Volume (0 to -39dB)

ATT	Volume	D0X	D1X	D2X	D3X	D4X	D5X	D6X
		D7X	D8X	D9X	DAX	DBX	DCX	DDX
	0dB	0	0	0	0	0	0	0
	-1dB	0	0	0	0	0	0	1
	-2dB	0	0	0	0	0	1	0
	-3dB	0	0	0	0	0	1	1
	-4dB	0	0	0	0	1	0	0
	-5dB	0	0	0	0	1	0	1
	-6dB	0	0	0	0	1	1	0
	-7dB	0	0	0	0	1	1	1
	-8dB	0	0	0	1	0	0	0
	-9dB	0	0	0	1	0	0	1
	-10dB	0	0	0	1	0	1	0
	-11dB	0	0	0	1	0	1	1
	-12dB	0	0	0	1	1	0	0
	-13dB	0	0	0	1	1	0	1
	-14dB	0	0	0	1	1	1	0
	-15dB	0	0	0	1	1	1	1
	-16dB	0	0	1	0	0	0	0
	-17dB	0	0	1	0	0	0	1
	-18dB	0	0	1	0	0	1	0
	-19dB	0	0	1	0	0	1	1
	-20dB	0	0	1	0	1	0	0
	-21dB	0	0	1	0	1	0	1
	-22dB	0	0	1	0	1	1	0
	-23dB	0	0	1	0	1	1	1
	-24dB	0	0	1	1	0	0	0
	-25dB	0	0	1	1	0	0	1
	-26dB	0	0	1	1	0	1	0
	-27dB	0	0	1	1	0	1	1
	-28dB	0	0	1	1	1	0	0
	-29dB	0	0	1	1	1	0	1
	-30dB	0	0	1	1	1	1	0
	-31dB	0	0	1	1	1	1	1
	-32dB	0	1	0	0	0	0	0
	-33dB	0	1	0	0	0	0	1
	-34dB	0	1	0	0	0	1	0
	-35dB	0	1	0	0	0	1	1
	-36dB	0	1	0	0	1	0	0
	-37dB	0	1	0	0	1	0	1
	-38dB	0	1	0	0	1	1	0
	-39dB	0	1	0	0	1	1	1

Note: Do not input other data than the above.

M61539FP

(3)-2 Volume (-40 to -∞dB)

ATT	Volume	D0X	D1X	D2X	D3X	D4X	D5X	D6X
		D7X	D8X	D9X	DAX	DBX	DCX	DDX
	-40dB	0	1	0	1	0	0	0
	-41dB	0	1	0	1	0	0	1
	-42dB	0	1	0	1	0	1	0
	-43dB	0	1	0	1	0	1	1
	-44dB	0	1	0	1	1	0	0
	-45dB	0	1	0	1	1	0	1
	-46dB	0	1	0	1	1	1	0
	-47dB	0	1	0	1	1	1	1
	-48dB	0	1	1	0	0	0	0
	-49dB	0	1	1	0	0	0	1
	-50dB	0	1	1	0	0	1	0
	-51dB	0	1	1	0	0	1	1
	-52dB	0	1	1	0	1	0	0
	-53dB	0	1	1	0	1	0	1
	-54dB	0	1	1	0	1	1	0
	-55dB	0	1	1	0	1	1	1
	-56dB	0	1	1	1	0	0	0
	-57dB	0	1	1	1	0	0	1
	-58dB	0	1	1	1	0	1	0
	-59dB	0	1	1	1	0	1	1
	-60dB	0	1	1	1	1	0	0
	-61dB	0	1	1	1	1	0	1
	-62dB	0	1	1	1	1	1	0
	-63dB	0	1	1	1	1	1	1
	-64dB	1	0	0	0	0	0	0
	-65dB	1	0	0	0	0	0	1
	-66dB	1	0	0	0	0	1	0
	-67dB	1	0	0	0	0	1	1
	-68dB	1	0	0	0	1	0	0
	-69dB	1	0	0	0	1	0	1
	-70dB	1	0	0	0	1	1	0
	-71dB	1	0	0	0	1	1	1
	-72dB	1	0	0	1	0	0	0
	-73dB	1	0	0	1	0	0	1
	-74dB	1	0	0	1	0	1	0
	-75dB	1	0	0	1	0	1	1
	-76dB	1	0	0	1	1	0	0
	-77dB	1	0	0	1	1	0	1
	-78dB	1	0	0	1	1	1	0
	-79dB	1	0	0	1	1	1	1
	-∞dB	1	0	1	0	0	0	0

Note: Do not input other data than the above.

(3)-3 Volume (-80 to -∞dB)

ATT	Volume	D0X	D1X	D2X	D3X	D4X	D5X	D6X
		D7X	D8X	D9X	DAX	DBX	DCX	DDX
	-∞dB	1	0	1	0	0	0	1
	-∞dB	1	0	1	0	0	1	0
	-∞dB	1	0	1	0	0	1	1
	↓							
	-∞dB	1	0	1	1	1	1	0
	-∞dB	1	0	1	1	1	1	1
	-80dB	1	1	0	0	0	0	0
	-81dB	1	1	0	0	0	0	1
	-82dB	1	1	0	0	0	1	0
	-83dB	1	1	0	0	0	1	1
	-84dB	1	1	0	0	1	0	0
	-85dB	1	1	0	0	1	0	1
	-86dB	1	1	0	0	1	1	0
	-87dB	1	1	0	0	1	1	1
	-88dB	1	1	0	1	0	0	0
	-89dB	1	1	0	1	0	0	1
	-90dB	1	1	0	1	0	1	0
	-91dB	1	1	0	1	0	1	1
	-92dB	1	1	0	1	1	0	0
	-93dB	1	1	0	1	1	0	1
	-94dB	1	1	0	1	1	1	0
	-95dB	1	1	0	1	1	1	1
	-∞dB	1	1	1	0	0	0	0
	-∞dB	1	1	1	0	0	0	1
	↓							
	-∞dB	1	1	1	1	1	1	0
	-∞dB	1	1	1	1	1	1	1

Electrical Characteristics

(Ta = 25°C, AVDD/AVSS/DVDD = 7/-7/5V, f = 1kHz unless otherwise noted.
Rg = 1kΩ, RL = 10kΩ, TONE CONTROL•VOL are set to 0dB/FLAT.)

(1) Power supply characteristics

Parameter	Symbol	Limits			Unit	Condition
		Min	typ	Max		
Analog positive circuit current	Aldd	—	22	35	mA	Current at pin29 No signal
Analog negative circuit current	Alss	—	22	35	mA	Current at pin 14 No signal
Digital circuit current	Didd	—	0.5	2.0	mA	Current at pin 26 No signal

(2) Input / Output characteristics

Parameter	Symbol	Limits			Unit	Condition
		Min	typ	Max		
Input resistance	Ri	35	70	150	kΩ	30, 32, 33, 35, 37, 39 pin
Maximum output voltage	VOM	3.0	4.2	—	Vrms	30, 32, 33, 35, 37, 39 pin INPUT 15 to 20pin OUTPUT THD = 1%
Pass gain	Gv	-2.0	0	2.0	dB	Vi = 0.2Vrms, FLAT 30, 32, 33, 35, 37, 39 pin INPUT 15 to 20pin OUTPUT
Distortion	THD	—	0.002	0.09	%	BW = 400 to 30 kHz, Vi = 0.2 Vrms, RL = 10 kΩ
Output noise voltage	Vn (VOL)	—	1.5	6	μVrms	15 to 20pin, Rg = 0kΩ, IHF-A, VOL = 0dB
	Vn (tone)	—	5	20	μVrms	15, 16pin IHF-A, VOL = 0dB
Maximum attenuation	ATTmax	—	-100	-95	dB	15 to 20pin IHF-A, VOL = -∞dB
Volume gain between channels	Dvol	-1.5	0	1.5	dB	
Cross talk between channels	CT	—	-80	-65	dB	Vo = 0.5Vrms, RL=10kΩ, IHF-A Rg = 1kΩ

(3) Tone control characteristics

Parameter	Symbol	Limits			Unit	Condition
		Min	typ	Max		
Tone control voltage gain	T+14dB	12	14	16	T+14dB	Vo = 0.2 Vrms
	T+12dB	10	12	14	T+12dB	TREBLE (f = 10 kHz),
	T+10dB	8	10	12	T+10dB	BASS (f = 100 kHz)
	T+8dB	6	8	10	T+8dB	
	T+6dB	4.5	6	7.5	T+6dB	Voltage gain
	T+4dB	2.5	4	5.5	T+4dB	INPUT to pin 37, 39
	T+2dB	1	2	3	T+2dB	OUTPUT from pin 16, 15
	T-2dB	-3	-2	-1	T-2dB	
	T-4dB	-5.5	-4	-2.5	T-4dB	
	T-6dB	-7.5	-6	-4.5	T-6dB	
	T-8dB	-10	-8	-6	T-8dB	
	T-10dB	-12	-10	-8	T-10dB	
	T-12dB	-14	-12	-10	T-12dB	
	T-14dB	-16	-14	-12	T-14dB	
Balance between channel	BALT	-1.5	0	+1.5	BALT	Input37, 39pin Vo=0.2Vrms Output16, 15pin

Test Circuit

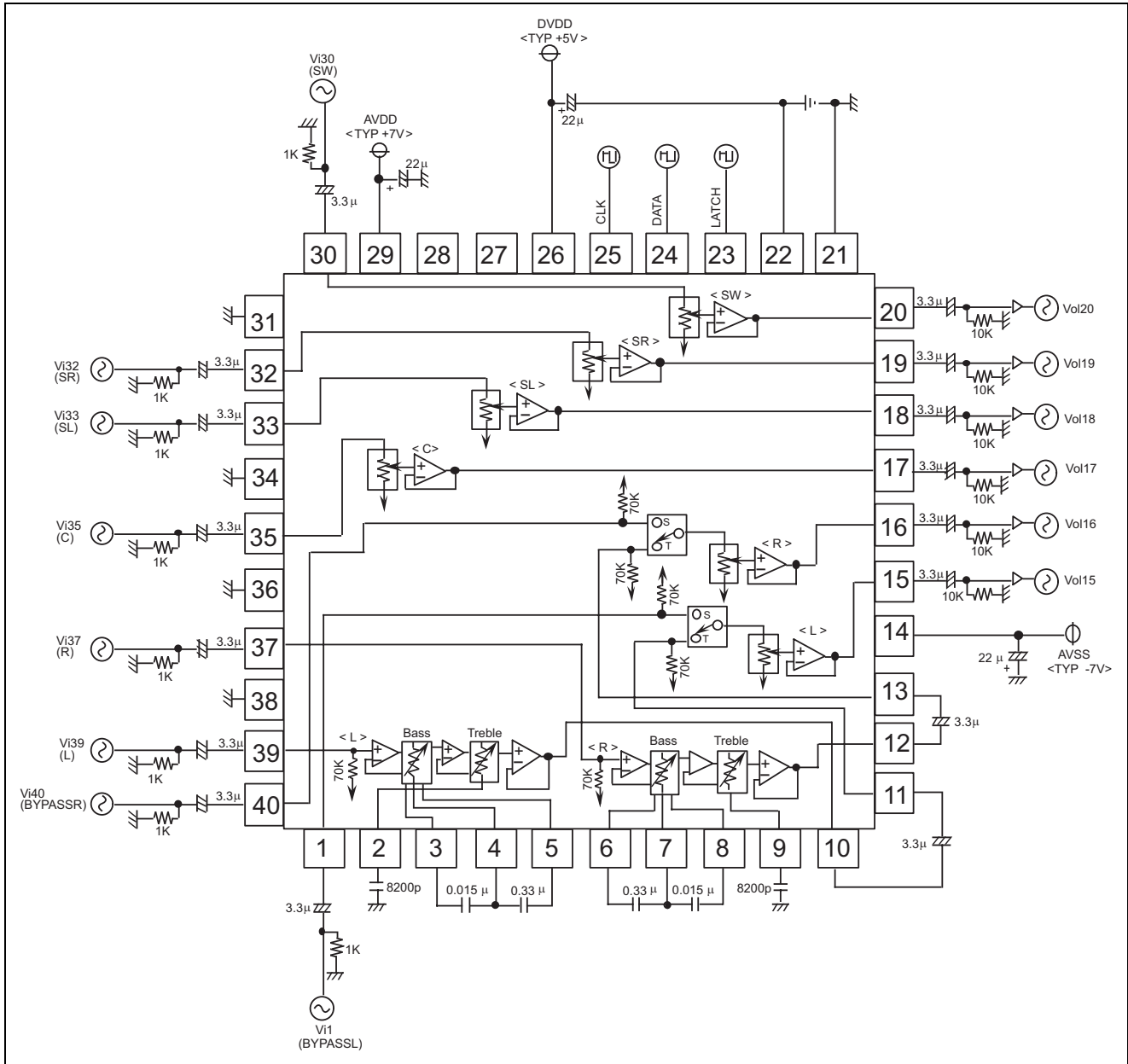

Signal Processing Diagram

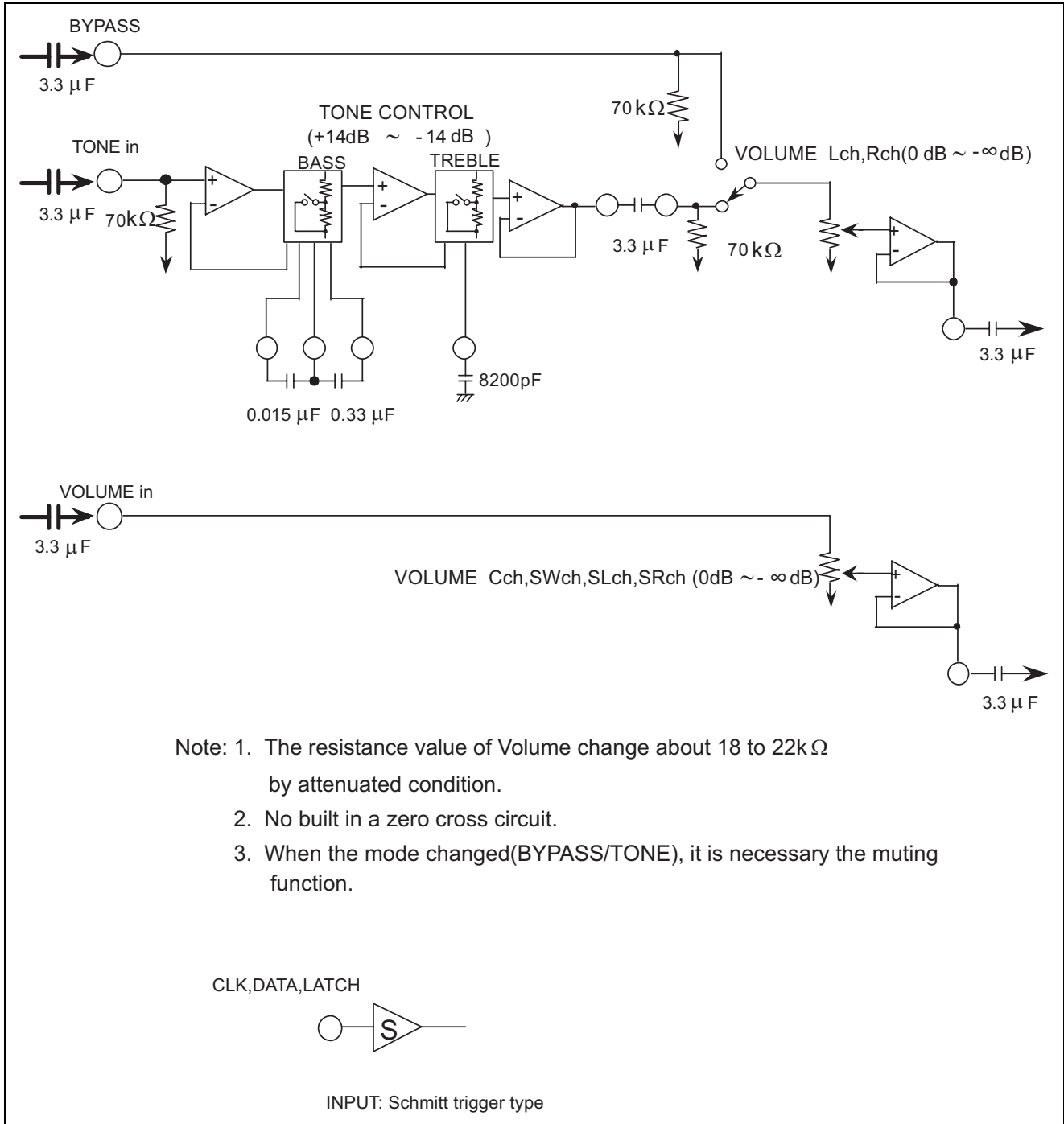

Application Example

(When using Tone control and Bypass)

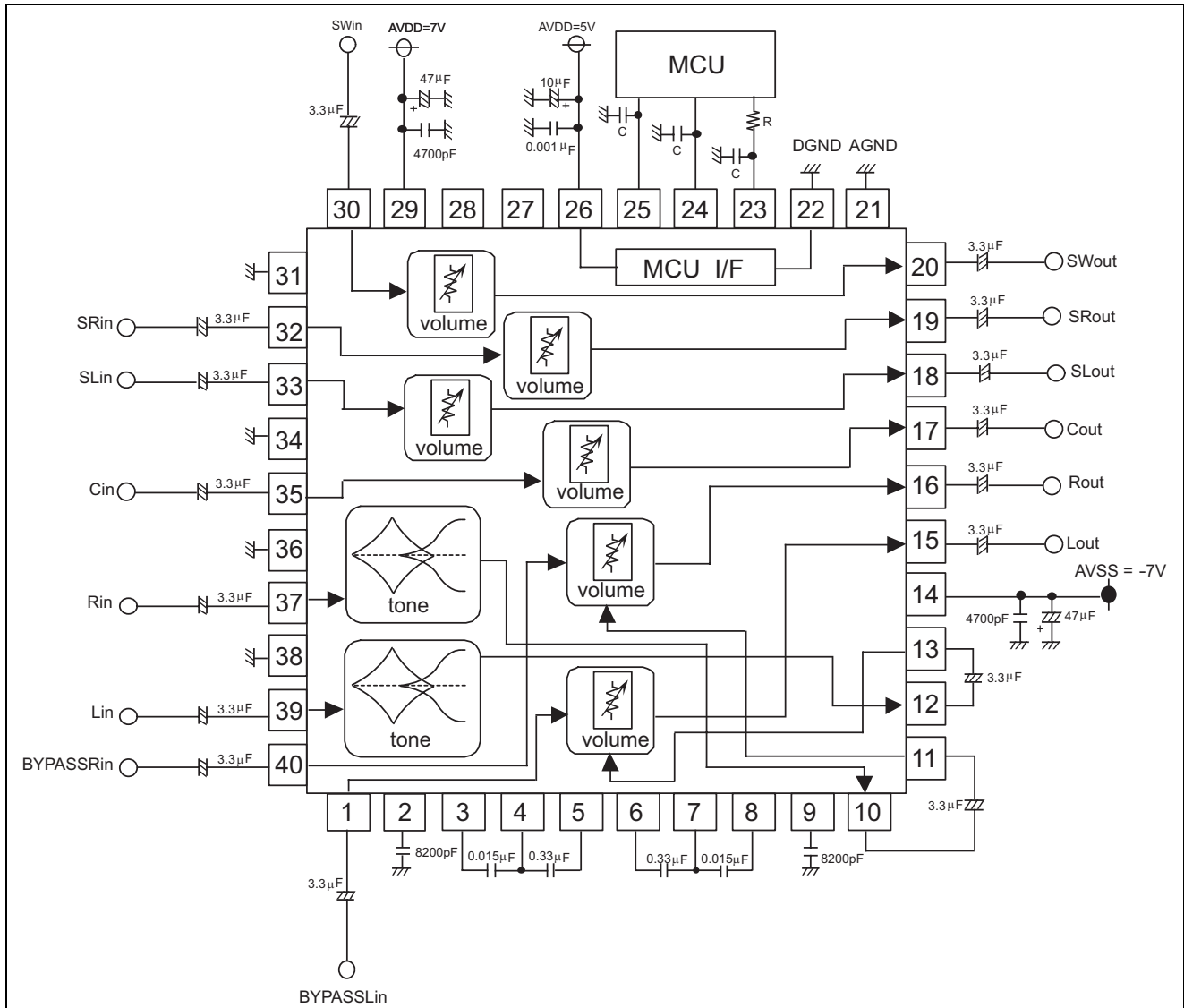

Note: To connect capacitor to DATA, CLOCK pin is the incorrect operation prevention by the noise.
 (Recommendation value :47 to 100pF)
 For the same reason, LATCH pin connect resistor and capacitor.
 (about 1kΩ, 330pF)

Package Dimensions

As of January, 2003
Unit: mm

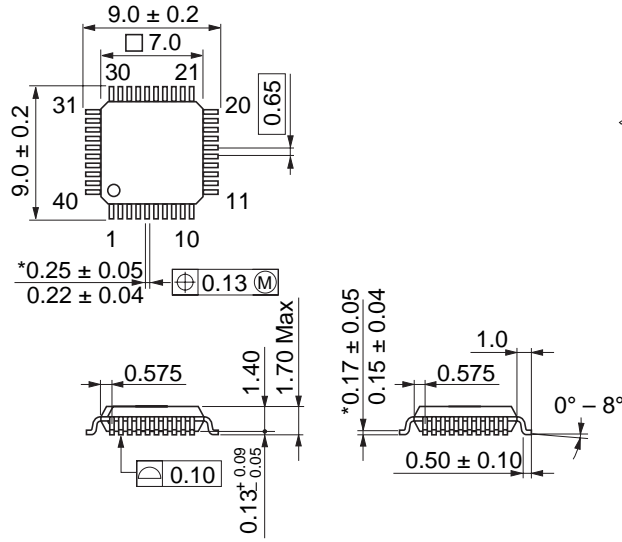

*Dimension including the plating thickness
Base material dimension

Package Code	FP-40B
JEDEC	—
JEITA	Conforms
Mass(reference value)	0.2 g

Renesas Technology Corp. Sales Strategic Planning Div. Nippon Bldg., 2-6-2, Ohte-machi, Chiyoda-ku, Tokyo 100-0004, Japan

Keep safety first in your circuit designs!

1. Renesas Technology Corp. puts the maximum effort into making semiconductor products better and more reliable, but there is always the possibility that trouble may occur with them. Trouble with semiconductors may lead to personal injury, fire or property damage. Remember to give due consideration to safety when making your circuit designs, with appropriate measures such as (i) placement of substitutive, auxiliary circuits, (ii) use of nonflammable material or (iii) prevention against any malfunction or mishap.

Notes regarding these materials

1. These materials are intended as a reference to assist our customers in the selection of the Renesas Technology Corp. product best suited to the customer's application; they do not convey any license under any intellectual property rights, or any other rights, belonging to Renesas Technology Corp. or a third party.
 2. Renesas Technology Corp. assumes no responsibility for any damage, or infringement of any third-party's rights, originating in the use of any product data, diagrams, charts, programs, algorithms, or circuit application examples contained in these materials.
 3. All information contained in these materials, including product data, diagrams, charts, programs and algorithms represents information on products at the time of publication of these materials, and are subject to change by Renesas Technology Corp. without notice due to product improvements or other reasons. It is therefore recommended that customers contact Renesas Technology Corp. or an authorized Renesas Technology Corp. product distributor for the latest product information before purchasing a product listed herein.
The information described here may contain technical inaccuracies or typographical errors.
Renesas Technology Corp. assumes no responsibility for any damage, liability, or other loss rising from these inaccuracies or errors.
Please also pay attention to information published by Renesas Technology Corp. by various means, including the Renesas Technology Corp. Semiconductor home page (<http://www.renesas.com>).
 4. When using any or all of the information contained in these materials, including product data, diagrams, charts, programs, and algorithms, please be sure to evaluate all information as a total system before making a final decision on the applicability of the information and products. Renesas Technology Corp. assumes no responsibility for any damage, liability or other loss resulting from the information contained herein.
 5. Renesas Technology Corp. semiconductors are not designed or manufactured for use in a device or system that is used under circumstances in which human life is potentially at stake. Please contact Renesas Technology Corp. or an authorized Renesas Technology Corp. product distributor when considering the use of a product contained herein for any specific purposes, such as apparatus or systems for transportation, vehicular, medical, aerospace, nuclear, or undersea repeater use.
 6. The prior written approval of Renesas Technology Corp. is necessary to reprint or reproduce in whole or in part these materials.
 7. If these products or technologies are subject to the Japanese export control restrictions, they must be exported under a license from the Japanese government and cannot be imported into a country other than the approved destination.
Any diversion or reexport contrary to the export control laws and regulations of Japan and/or the country of destination is prohibited.
 8. Please contact Renesas Technology Corp. for further details on these materials or the products contained therein.
-



RENESAS SALES OFFICES

<http://www.renesas.com>

Renesas Technology America, Inc.
450 Holger Way, San Jose, CA 95134-1368, U.S.A
Tel: <1> (408) 382-7500 Fax: <1> (408) 382-7501

Renesas Technology Europe Limited.
Dukes Meadow, Millboard Road, Bourne End, Buckinghamshire, SL8 5FH, United Kingdom
Tel: <44> (1628) 585 100, Fax: <44> (1628) 585 900

Renesas Technology Europe GmbH
Dornacher Str. 3, D-85622 Feldkirchen, Germany
Tel: <49> (89) 380 70 0, Fax: <49> (89) 929 30 11

Renesas Technology Hong Kong Ltd.
7/F., North Tower, World Finance Centre, Harbour City, Canton Road, Hong Kong
Tel: <852> 2265-6688, Fax: <852> 2375-6836

Renesas Technology Taiwan Co., Ltd.
FL 10, #99, Fu-Hsing N. Rd., Taipei, Taiwan
Tel: <886> (2) 2715-2888, Fax: <886> (2) 2713-2999

Renesas Technology (Shanghai) Co., Ltd.
26/F., Ruijin Building, No.205 Maoming Road (S), Shanghai 200020, China
Tel: <86> (21) 6472-1001, Fax: <86> (21) 6415-2952

Renesas Technology Singapore Pte. Ltd.
1, Harbour Front Avenue, #06-10, Keppel Bay Tower, Singapore 098632
Tel: <65> 6213-0200, Fax: <65> 6278-8001